

Catalogue Heating, Air-conditioning Cooling and Water Supply

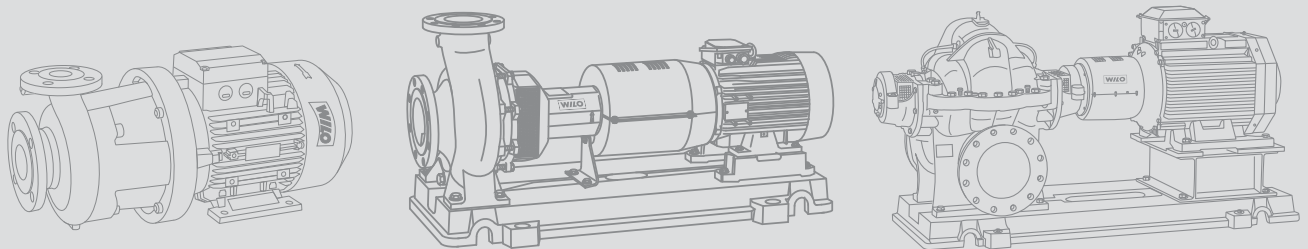



Monobloc and Norm Pumps, Axially Split Case Pumps

Pumps
and Accessories



Programme overview and fields of applications

Glanded pumps

Pump type	Main field of application	Fields of application				Page
						

Energy-saving pumps

Single pumps	Wilo VeroLine-IP-E	•	•	•	-	1)
	Wilo CronoLine-IL-E	•	•	•	-	
	Wilo-CronoLine-IL-E...BF	•	•	•	-	
Double pumps	Wilo VeroTwin-DP-E	•	•	•	-	
	Wilo CronoTwin-DL-E	•	•	•	-	
	 Wilo-CronoTwin-DL-E...BF	•	•	•	-	

Standard pumps

Single pumps	Wilo VeroLine-IPL	•	•	•	-	1)
	Wilo CronoLine-IL	•	•	•	-	
Double pumps	Wilo VeroTwin-DPL	•	•	•	-	
	Wilo CronoTwin-DL	•	•	•	-	

Special in-line pumps

Single pumps	Wilo VeroLine-IPS	•	•	•	-	1)
	Wilo-VeroLine-IPH-O/-W	•	•	•	-	
	Wilo-VeroLine-IP-Z	•	•	•	•	

Monobloc pumps

Single pumps	Wilo BAC	-	•	•	-	18
	Wilo-CronoBloc-BL	•	•	•	-	23

Norm pumps

Single pumps	Wilo CronoNorm NL	•	•	•	-	44
	Wilo VeroNorm-NPG	•	•	•	-	84

Axially split case pumps

Single pumps	 Wilo SCP	-	•	•	-	108
--------------	---	---	---	---	---	-----

Key:

- Applicable
- Cannot be used
- ¹⁾ See Wilo catalogue A2 – Glanded pumps in inline construction

 **New in the programme or series extension or modification**

Fields of application:



Heating



Air-conditioning/cooling



Industrial applications







Secondary hot water circulation

General notes and abbreviations	4
<hr/>	
Planning guide	6
<hr/>	
Monobloc pumps	14
<hr/>	
Wilo-BAC Wilo-CronoBloc-BL	
Norm pumps	42
<hr/>	
Wilo-CronoNorm NL Wilo-VeroNorm-NPG	
Axially split case pumps	106
<hr/>	
Wilo-SCP	
Switchgears and control devices	160
<hr/>	
Wilo-VR, CRn, CR control devices	

General notes and abbreviations

Abbreviations used and what they mean

Abbreviation	Meaning
1~	1-phase current
3~	3-phase current
Autopilot	Automatic adjustment of the pump output in setback phases, e. g. boiler setback operation during the night.
blsf	Blocking current-proof, no motor protection necessary
CAN	CAN (Controller Area Network) – Multi master bus system, in which several equal CAN-devices may communicate via a 2-core bus within very short cycle times. The Wilo-CAN bus includes a CANopen Standard (EN 50325-4) which is independent of the supplier.
DM	Three-phase motor, 3~
DN	Nominal diameter of the flange connection
Δp	Pressure loss
$\Delta p-c$	Control mode for constant differential pressure
$\Delta p-T$	Control mode for differential pressure control depending on the fluid temperature
$\Delta p-v$	Control mode for variable differential pressure
ΔT	Control mode for differential temperature
EBM	Individual run signal
ECM technology	Electronically commutated motor with new damp-room enclosure, newly developed glandless drive concept for high-efficiency pumps
EM	Single-phase motor, 1~
EnEV	German Energy Conservation Legislation
ESM	Individual fault signal
Ext. Off	"Overriding Off" control input
Ext. Min	Control input „Overriding Min“, e. g. for setback operation without Autopilot
FI	Residual current-operated protective device
BA	Building automation
GRD/GLRD	Mechanical seal
°dH	Degree of German water hardness; formerly used unit for assessing the water hardness. Is no longer used since the SI-unit mmol/l has been introduced. Conversion: 1 °dH = 0.1783 mmol/l
H	Delivery head
IF	Interface
Int. MS	Internal motor protection: Pumps with internal protection against unacceptably high winding temperatures
IR	Infrared interface

Abbreviation	Meaning
KDS	Capacitor
KLF	PTC thermistor sensor
KTL-coating	Electrophoretic painting (cataphoretic coating): Painting with high adhesive strength for long-lasting corrosion protection
KTW	Approval for products with plastics, for use in potable water applications
LON	Local Operating Network (open, standardised data bus system independent of manufacturer in LON-Works networks)
mmol/l	Millimol per litre; SI-unit for assessing the water hardness (total hardness or concentration of alkaline earth ions)
MOT	Motor module (drive motor + impeller+ terminal box/electronic module) for replacement of TOP-...-series
P_1	Power consumption (power supplied from the grid)
PLR	Pump master computer, Wilo-specific data interface
$Q (= \dot{V})$	Volume flow
RMOT	Spare motor (drive motor + impeller + terminal box/electronics module) for replacement
SBM	Run signal or collective run signal
SSM	Fault signal or collective fault signal
Control input 0 – 10 V	Analogue input for external activation of functions
TrinkwV 2001	German Drinking Water Ordinance of 2001 (valid from 01.01.2003)
VDI 2035	VDI guideline for preventing damage in hot-water heating installations
Wilo-Control	Building automation management with pumps and accessories
WRAS	Water Regulations Advisory Scheme (potable water approval for Great Britain and Northern Ireland)
WSK	Thermal winding contacts (in motor for monitoring the winding temperature, full motor protection by additional tripping unit)
	Operating mode of double pumps: Individual operation of the relevant operating pump
	Operating mode of double pumps: Parallel operation of both pumps
	Number of poles of electric motors: 2-pole motor = approx. 2900 rpm at 50 Hz
	Number of poles of electric motors: 4-pole motor = approx. 1450 rpm at 50 Hz
	Number of poles of electric motors: 6-pole motor = approx. 950 rpm at 50 Hz

Material designations and their meaning

Material	Meaning
1.4021	Chrome steel X20Cr13
1.4034	Chrome steel X46Cr13
1.4057	Chrome steel X17CrNi16-2
1.4122	Chrome steel X39CrMo17-1
1.4301	Chromium nickel steel X5CrNi18-10
1.4305	Chromium nickel steel X8CrNi18-9
1.4306	Chromium nickel steel X2CrNi19-11
1.4401	Chromium nickel molybdenum steel X5CrNiMo17-12-2
1.4408	Chromium nickel molybdenum steel GX5CrNiMo19-11-2
1.4462	Chromium nickel molybdenum steel X2CrNiMoN22-5-3
1.4541	Chromium nickel steel with titanium addition X6CrNiTi18-10
1.4542	Chromium nickel steel with copper and niobium addition X5CrNiCuNb16-4
1.4571	Chromium nickel steel with titanium addition X6CrNiMoTi17-12-2
Abrasite	Chilled cast iron for use with heavily abrasive fluids
Al	Aluminium
Ceram	Liquid ceramic coating; coating with very high adhesive strength for long-lasting corrosion protection
COMPOSITE	High-strength plastic material
EN-GJL	Cast iron (with lamellar graphite)
EN-GJS	Cast iron (with spheroidal cast iron)
G-CuSn10	Zinc-free bronze
GfK	Glass fibre reinforced plastic
GG	see EN-GJL
GTW	Special cast iron: white malleable cast iron
GGG	see EN-GJS
Inox	stainless steel
NiAl-Bz	Nickel aluminium bronze
PPO	Trade name: Noryl, fibreglass-reinforced plastic
PP-GF30	Polypropylene, reinforced with 30% fibreglass
PUR	Polyurethane
SiC	Silicon carbide
ST	Steel
V2A	Material group, e.g. 1.4301, 1.4306
V4A	Material group, e.g. 1.4404, 1.4571

Wear and tear

Pumps or parts of pumps are subject to wear in accordance with state-of-the-art technology (DIN 31051/DIN-EN 13306). This wear may vary depending on operating parameters (temperature, pressure, speed, water condition) and installation/usage situation and may result in the malfunction or failure at different times of the above-mentioned products/components including their electrical/electronic circuitry.

Wear parts are all components subject to rotary or dynamic strain including electronic components under tension, in particular:

- Seals (incl. mechanical seal), seal ring
- Stuffing box
- Bearing and shaft
- Impellers and pump part
- Ball race and wear ring
- Wear ring / wear plate
- Macerator
- Capacitor
- Relay / contactor / switch
- Electronic circuits, semiconductor components etc.

Pumps and continuous-flow machines (lie submersible mixers and recirculation pumps), as well as their components with coatings (cathaphoresis coating, 2K- or Ceram-coating) are subject to constant wear due to the abrasive fluid contents. It is for that reason that the coating is also listed with the wearing parts contained in these units!

We do not accept liability for faults or defects arising from natural tear and wear.

Note

In accordance with **German Energy Saving Ordinance [Energieeinspar-Verordnung EnEV]** as of the 1.2.2002 at boiler outputs from 25 kW, heating pumps are to be equipped with switchgears for automatic performance control or **electronically controlled pumps** are to be installed.

In accordance with **TrinkwV 2001** and **DIN 50930-6**, only circulating pumps with corrosion-resistant pump housings made of stainless steel or red brass (CC 499K) are to be utilised in secondary hot water circulation systems.

Pump replacement

Detailed information on the subject of "Replacing heating pumps" can be found in the current Wilo replacement guide for heating pumps.

Wilo – General terms of delivery and service

The latest version of our general terms of delivery and service can be found on the Internet at

www.wilo.com/agb

Planning guide

Note on range of application

This planning guide applies to:

- Electronically controlled in-line pumps of the series: IP-E, DP-E, IL-E, DL-E, IL-E .. BF, DL-E .. BF
- Uncontrolled in-line pumps of the series: IPL, DPL, IL, DL, IPs, IPH-O/-W, IP-Z
- Monobloc pumps of the BL series

Pump selection

Glanded pumps are ideally suited for use in conjunction with large plant systems covering a wide range of applications in the field of hot water and air-conditioning/cooling. The technically correct selection of a pump involves a number of factors:

- The correct pump size to achieve the required duty point
- The correct pump series to fulfil the process parameters (e.g. pressure and temperature)
- The right materials to fulfil endurance requirements.

The overview duty charts in the **Program overviews** section of the catalogue allow you to roughly select the pump series you need, helping you to select the most suitable size of pump within the respective series more quickly. Frequently, pumps of various series are found to be hydraulically suitable in the border area of the duty charts. Accurate selection of the required pump size is possible only with the aid of the individual pump curve. These are provided in this catalogue and in the Wilo planning software (available on CD-ROM and online at www.wilo-select.com).

The **Technical data** section of the catalogue provides information on the application limits with respect to pressure, temperature and material options. In addition, this section of the catalogue provides information on the pump equipment.

Pump curve

An ideally dimensioned pump has its duty point in the region of maximum efficiency. At the duty point, there is a balance between the performance capacity of the pump (figure 1, curve P) and the power consumption required to overcome the resistance of the pipe system (figure 1, curve A1). Tolerances in accordance with ISO 9906, Appendix 1, are to be taken into account for all of the pump curves illustrated.

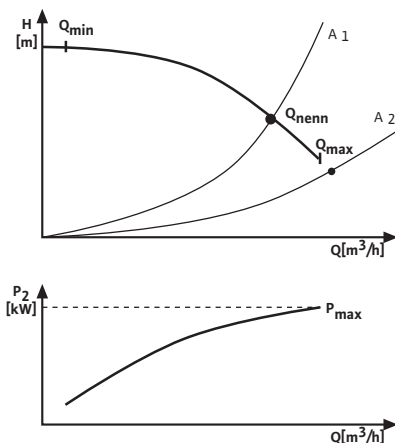

Figure 1

The point of highest efficiency is approximately in the upper third of the pump curve, or is indicated on the performance diagram. The planning engineer must find a duty point to match the maximum requirements of the pump.

In the case of a heating pump, this is the capacity to meet the calculated standard heating load of the building. All other duty points that occur in practice lie on the pump curve to the left of the duty point Q_{nominal} . The pump thus operates within its highest efficiency range. If the actual resistance of the pipe system is lower than that on which the pump selection has been based, then the duty point may lie outside the pump curve (figure 1, curve A₂). This may lead to an unacceptably high power consumption and hence to an overload of the selected motor. In this case it is necessary to redetermine the duty point and, if necessary, use a more powerful pump. The minimum volume flow Q_{min} of a glanded pump is 10% of Q_{max} (figure 1). The incremental pump curves provided for pumps and, in particular, for power selection, are intended for use when there is reliable knowledge of the duty point. If reliable knowledge of the duty point is not available, our basic recommendation is to select the pump with the maximum electrical power.

Cavitation

The selection of the right pump also includes the prevention of cavitation. This is particularly the case in open systems (e.g. cooling tower systems) and at very high temperatures and low system pressures. The pressure drop in a flowing fluid, e.g. due to frictional resistance in the pipe, a change in absolute velocity or the geodetic head, leads to the local formation of vapour bubbles when the static pressure falls to the vapour pressure of the fluid (Fig. 2).

The vapour bubbles are carried along by the flow, collapsing suddenly if the static pressure increases again above the vapour pressure (Fig. 3).

Negative pressure

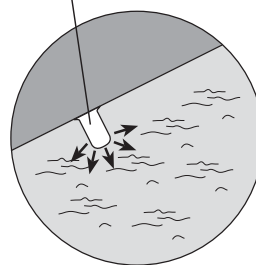

Fig. 2

Positive pressure

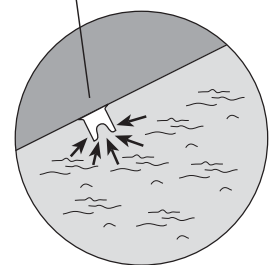

Fig. 3

This process is called cavitation. The collapse of the vapour bubbles causes micro-jets which, on hitting the surface of a wall, cause destruction of the wall material.

To avoid cavitation, special attention must therefore be given to the maintenance of the correct pressure. If the available intake pressure (or static pressure) in the pipe system is not high enough to meet the static head required for the pump (net positive suction head or NPSH), appropriate measures must be taken to increase the static head to at least achieve a balance. This can be done by:

- Increasing the static pressure (pump positioning).
- Reducing the fluid temperature (reduced vapour pressure pD)
- Selecting a pump with a lower net positive suction head (NPSH) (as a rule a larger pump)

Net positive suction head NPSH

The net positive suction head (NPSH) is pump-specific and is displayed in the performance diagram for the pump (Fig.4). The NPSH values are based on the respective maximum impeller diameter. In order to allow for any uncertainty in the specification of the duty point, when selecting the pump, the values should be increased by a **margin of safety of 0.5 m**.

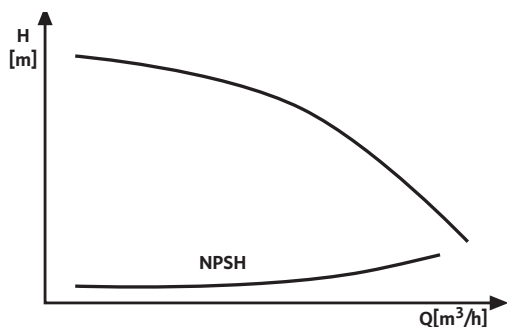

Fig. 4

Series

A hydraulically suitable pump must also meet the required operating conditions. For this, it is necessary to check the maximum permissible operating temperature and pressure first.

Design

In-line pumps

Wilo in-line pumps are single-stage, low-pressure centrifugal pumps in in-line design with suction and pressure ports of the same nominal diameter and with air-cooled IEC standard motors. PN 16 flanges with pressure measuring connections R ¹/₈. The pump housing is standard-equipped with feet.

Monobloc pumps

Wilo monobloc pumps are single-stage, low-pressure centrifugal pumps in block design in accordance with EN 733 with air-cooled IEC standard motors. Spiral housing made of cast iron with axial suction port and radially arranged pressure port, PN 16 flanges with pressure measuring connections R ¹/₈. The pumps are standard-equipped with angled or motor feet.

Materials

The selection of materials for all parts that come in contact with the fluid is of importance for the chemical resistance of the pump.

The material selection table provides an overview of the most important components. In addition to the resistance of glanded pumps, particular significance is attached to the functional capability of the mechanical seal.

Materials									
Fluids	Application limits	Materials Housing/impeller		Shaft seal Mechanical seal			Housing seal		
		Grey cast iron/grey cast iron	Grey cast iron/bronze or plastic ¹⁾	Standard: AQ1EGG	S1: Q1Q1X4GG	S2: AQ1X4GG	EPDM	Viton	HNBR
(The maximum permissible operating temperatures and pressures of the pump series must be adhered to)									
Heating water (in accordance with VDI 2035) (Conductivity <300 µs, silicates <10 mg/l, solid matter content <10 mg/l)	up to 140 °C	•	-	•	-	-	•	-	-
Cooling and cold water	up to -20 °C	•	-	•	-	-	•	-	-
Cooling brine, inorganic, pH > 7.5, inhibited	up to 30 °C	•	-	•	-	-	•	-	-
Water-glycol mixtures, 20-40 vol.% glycol	-20 °C to 40 °C	•	-	•	-	-	•	-	-
Water-glycol mixtures, 20-40 vol.% glycol	40 °C to 90 °C	•	-	-	o	-	-	-	o
Water-glycol mixtures, 40-50 vol.% glycol	-20 °C to 90 °C	•	-	-	o	-	-	-	o
Water-glycol mixtures, 20-50 vol.% glycol	90 °C to 120 °C	•	-	-	o	-	-	-	o
Water with oil in suspension	0 °C to 90 °C	•	-	-	-	o	-	o	-
Mineral oil (Observe operating regulations with regard to explosion protection)	-20 °C to 140 °C	•	-	-	-	o	-	o	-

• = standard, o = special equipment

¹⁾for IPL, DPL, IP-E, DP-E standard plastic impellers, IPL and DPL in parts with grey cast iron impeller

Planning guide

Materials

Swimming-pool water (Chloride <250 mg/l, install pump upstream of filter)	up to 35°C	–	o	–	–	–	–	–	o
Fire water	up to 30°C	–	o	–	–	–	–	–	o

• = standard, o = special equipment

¹⁾for IPL, DPL, IP-E, DP-E standard plastic impellers, IPL and DPL in parts with grey cast iron impeller

Mechanical seal

A **mechanical seal** is fitted as standard on all Wilo glanded pumps (except IPs) (Fig. 5). Mechanical seals are dynamic seals and are used to seal rotating shafts at medium to high pressures. The dynamic sealing area of the mechanical seal consists of two surface-ground, low-wearing faces (e.g. silicon carbide or carbon rings), which are pressed together by axial forces. The slip ring rotates with the shaft, while the counter ring remains stationary in the housing. The rings are pressed together by a spring and the fluid pressure.



Fig. 5

As a rule, there is little or no drip leakage during operation, and no maintenance work is necessary. The average service life, under average operating and water conditions, is between 2 and 4 years. However, extreme conditions (soiling, admixtures and overheating) may drastically reduce the service life.

Important:

Mechanical seals are wearing parts. Dry running is not permissible as it will lead to the destruction of the sealing faces.

The mechanical seal fitted as standard by Wilo can be used for water-glycol mixtures with 20 - 40 vol.% glycol and a fluid temperature of ≤ 40°C.

Outside the limits of these parameters, silicate precipitation may occur, which could damage the standard seals. Special versions are available on request for use outside these limits. When additives such as glycol are used, or if oil-polluted water is encountered, then in addition to the suitability of the mechanical seal, **it may also be necessary to check the performance of the pump (in the case of glycol admixtures exceeding 20% volume proportion).**

The following formula can be applied to determine the **power requirement P₂** of a pump:

$$P_2 = \frac{\rho \times Q \times H}{367 \times \eta}$$

P ₂	Power requirement [kW]
ρ	Density [kg/dm ³]
Q	Volume flow [m ³ /h]
H	Delivery head [m]
η	Pump efficiency (e.g. 0.8 at 80%)

Mechanical seals – material identification code

The materials of a mechanical seal are identified by means of a 5-part code. The "Technical data" tables for the glanded pumps contain the code for each series. The code characters relate to the following seal components:

- 1: Slip ring
- 2: Counter ring
- 2: Secondary seals
- 4: Spring
- 5: Other components

Typical materials:

- 1: **A** Carbon-graphite (antimony impregnated)
- B** Carbon-graphite (synthetic resin impregnated), approved for use with foods
- Q1** Silicon carbide
- 2: **Q1** Silicon carbide
- 3: **E** EPDM
- E3** EPDM, approved for use with foods
- V** Viton
- X4** HNBR
- 4: **G** Stainless steel
- 5: **G** Stainless steel

The standard seal on Wilo glanded pumps is **AQ1EGG**.

Cataphoretic coating

Wilo glanded pumps are provided as standard with a cataphoretic coating (exceptions: IL 250, IPS, IPH-O, IPH-W, IP-Z series). External components which are susceptible to corrosion such as hexagon head bolts, couplings etc., are chromated. The advantages of these coatings lie in their resistance to corrosion caused by aggressive atmospheres, such as humid air, condensation and an environment containing salt and chemicals. To prevent rust, pumps with cast components with a cataphoretic coating and chromated components are suitable for heating and air-conditioning/cooling applications both indoors and outdoors (a special motor is required for outside applications). These pumps also offer the advantage of low maintenance costs and a longer service life.

Thermal insulation of pumps

In systems, which are heat-insulated, only the pump housing should be insulated, not the lantern or the motor.

Installation location/position of the pumps

The standard pumps must be protected from the weather and installed in a frost/dust-free, well-ventilated and non-explosive environment. Pipes and pumps are to be installed in a stress-free condition. The pipes must be mounted in such a way that the pump does not bear the weight of the pipe.

In-line pumps are designed for direct horizontal and vertical installation in a pipe. Installation with the motor and the terminal box facing downwards is not permitted. Sufficient space must be provided for the removal of motor, lantern and impeller. With a motor power in excess of 18.5 kW, it is not permitted to install the pump with the pump shaft in a horizontal position. With a vertically mounted pump, the pipe must be stress-free and the pump must be supported on the pump feet.

The installation of monobloc pumps with the motor and terminal box facing downwards is not permitted. All other installation positions are possible. Monobloc pumps are to be mounted on a sufficiently strong base or brackets.

Anticipated noise levels for in-line and monobloc pumps (guideline values)

Motor power P _N [kW]	Sound-pressure level pA (dB) ¹⁾ Pump with motor	
	1450 rpm	2900 rpm
< 0.55	52	55
0.75	53	58
1.1	54	58
1.5	54	61
2.2	57	62
3.0	58	64
4.0	58	67
5.5	63	70
7.5	64	71
11.0	67	74
15.0	68	75
18.5	67	76
22.0	67	77
30.0	69	78
37.0	68	74
45.0	68	74
55.0	68	78
75.0	70	80
90.0	70	80
110.0	72	82
132.0	72	82
160.0	72	82

¹⁾Spatial mean value of sound pressure levels on a square measuring surface at a distance of 1 m from the surface of the motor

Electrical drive

The **rated output values** and operating values for the electrical drives specified in this catalogue for glanded pumps (in-line and monobloc) apply to a rated frequency of 50 Hz, a rated voltage of 230/400 V up to 3 kW or 400/690 V above 4 kW, a maximum coolant temperature (CT) of 40°C and an installation altitude of up to 1000 m above mean sea level.

For cases outside these parameters a reduction of the rated output must be applied or a larger motor type or a higher insulation class must be selected.

All Wilo glanded pumps are standard-equipped with electric motors, which meet the IEC standard in terms of output and design. A restric-

tion only applies where, due to the design of the pump, coupling to a standard motor is not possible. In this case, motors with an extended shaft are used. The customary speed categories/operating speeds are as follows:

Number of poles	50 Hz	60 Hz
2	2900 rpm	3500 rpm
4	1450 rpm	1750 rpm
6	950 rpm	1150 rpm

High-efficiency motor



Wilo glanded pumps are available with EFF1 high-efficiency motors on, for a motor power in excess of 1.1 kW.

Use of explosion-protected pumps according to Directive 94/9/EG (ATEX100a)

Potentially explosive areas are zones where an explosive atmosphere (gas/dust) can occur in sufficient measure to pose a risk.

These areas are divided into zones. Decisions on the assignment of zones lie with the operator and the respective regulation authority. The testing of pumps (machines) and hence the approval for use in hazardous areas is governed in the EU on the basis of the relevant explosion protection specification 94/9/EG (ATEX100a) by appropriate authorised institutes. Approval is granted by means of a prototype test certificate. Wilo glanded pumps of the IL, DL, BL, IPL (only version -N), DPL (only version -N), IPS and IPH series can be supplied according to the specifications for use in potentially explosive areas.

These pumps have a prototype test certificate in accordance with Directive 94/9/EG (ATEX100a), which permits the following designations to be applied:

II 2 G c b II A T3, T4 / II 2 G c b II C T3, T4

CE	CE marking
II	Device group
G	Explosive atmosphere due to gases, vapours and mist
C	Design safety (protection due to safe design)
b	Ignition source monitoring with T4
T1 - T4	Temperature class with maximum surface temperature
T1	450 °C
T2	300 °C
T3	200 °C
T4	135 °C

E/D Motor ignition protection category

e	Increased safety
d	Pressure-proof enclosure

Particular attention must be paid to ensure that for applications in the T4 temperature range, the pumps and mechanical seals are additionally protected against dry running.

This can take the form, for example, of monitoring the differential pressure or the nominal motor power.

The motors have their own specific designations, e.g. EEX eII T3 which stands for:

Planning guide

- e Motor according to European standard
 - Ex Explosion protection
 - e Ignition protection category "Increased safety"
 - II Motor for potentially explosive areas
 - T3 Temperature class
- and must also be approved in accordance with Directive 94/9/EG (ATEX100a).

The approved operating conditions are listed in the following matrix:

Important:

Attention must also be paid in each application case to the special features relating to the dependency on temperature, pressure, fluid and mechanical seal. The pumps may only be used for the permitted fluids listed in the following matrix (II B). However, outside the pump, the presence of gases according to the EX groups and temperature classes is permitted (II C).

Matrix of permissible operating conditions

Fluid II A	Mechanical seal	Number of motor poles	IL/DL/BL				IPL/DPL	
			Maximum permissible fluid temperature				Maximum permissible fluid temperature	
			T4 ¹⁾		T3		T4 ¹⁾	T3
			P = 10 bar	P = 16 bar	P = 10 bar	P = 16 bar	P = 10 bar	P = 10 bar
Heating water in accordance with VDI 2035	Standard	2-pole	100 °C	90 °C	140 °C	120 °C	120 °C	120 °C
		4-pole	115 °C	110 °C	140 °C	120 °C	120 °C	120 °C
Partially desalinated water with: conductivity > 80 µs, silicates < 10 mg/l, pH value > 9	Standard	2-pole	100 °C	90 °C	140 °C	120 °C	120 °C	120 °C
		4-pole	115 °C	110 °C	140 °C	120 °C	120 °C	120 °C
Mineral oil	G2 / S2	2-pole	75 °C	50 °C	140 °C	115 °C	105 °C	120 °C
		4-pole	95 °C	80 °C	140 °C	120 °C	115 °C	120 °C
Heating water with: conductivity < 850 µs, silicates < 10 mg/l, solid matter content < 10 mg/l	Standard	2-pole	100 °C	90 °C	120 °C	120 °C	120 °C	120 °C
		4-pole	115 °C	110 °C	120 °C	120 °C	120 °C	120 °C
Condensate	Standard	2-pole	100 °C	90 °C	100 °C	100 °C	100 °C	100 °C
		4-pole	100 °C	100 °C	100 °C	100 °C	100 °C	100 °C
Cooling brine, inorganic; pH value > 7.5, inhibited	Standard		20 °C	20 °C	20 °C	20 °C	20 °C	20 °C
Water with oil contamination	G2 / S2		90 °C	90 °C	90 °C	90 °C	90 °C	90 °C
Cooling water with antifreeze (pH value: 7.5-10; no galvanised components)	Standard		40 °C	40 °C	40 °C	40 °C	40 °C	40 °C
Water-glycol mixture (20% - 40% glycol)	Standard		40 °C	40 °C	40 °C	40 °C	40 °C	40 °C

¹⁾Pumps and mechanical seals must be additionally protected against dry running in the T4 temperature range. This can be achieved by monitoring the differential pressure or the nominal power of the motor.

⊗
The use of solvents is not permitted, since they could corrode the elastomers in the seals. In turn, this can lead to uncontrolled leakage!

Scope of delivery

Pump, including packaging, installation and operating instructions

Accessories

Electronically controlled in-line pumps:

- IF-Module: PLR or LON for the IP-E, DP-E, IL-E, DL-E series (also see catalogue section: "Switchgears and control systems").
- IR-Monitor for the IP-E, DP-E, IL-E, DL-E series. Interface converters analogue (also see catalogue section: "Switchgears and control systems").
- Interface converters digital (also see catalogue section: "Switchgears and control systems").

- Brackets for installation on a base
- Blind flanges for double pumps

Uncontrolled in-line and monobloc pumps:

- Wilo control system for infinitely variable speed control for pump operation according to requirements.
- Switchgears for the automatic control of duty and standby pumps (also see catalogue section: "Switchgears and control systems").
- Brackets for installation on a base
- Blind flanges for double pumps

Pump duty splitting

In the context of infinitely variable output control, the "split solution" is available for optimisation, starting with the medium pump output range (1-1.5 kW), i.e. instead of using a large pump, the maximum output is split up between two smaller pump units or a double pump.

In the normal case, i.e. for more than 85% of the heating season, one pump is adequate as the basic load unit. The second pump is available to fulfil peak-load requirements.

Important:

The extra costs for the pumps are more than compensated for by power savings by the control device.

Advantages of pump duty splitting:

- Electricity savings of between 50% and 70%
 - A second pump is always available on standby.
- With the so-called "split solutions", one pump is operated for basic load requirements, while the other pumps are cut in for parallel peak-load operation. This ensures that the design requirement is in accordance with DIN 4701. In conjunction with controlled units, continuous adjustment to the load demand can be achieved over the entire performance range.

Important:

Wilco control systems for double-pump or multi-pump installations feature the peak-load cut-in option.

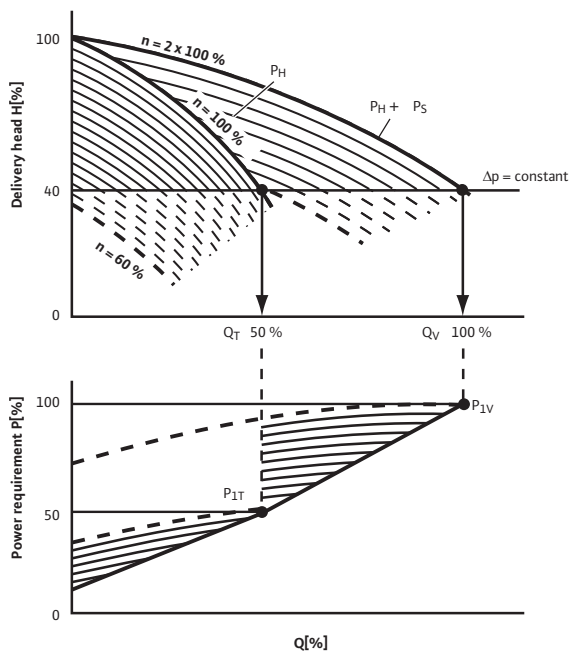

Fig.: Infinitely variable controlled peak-load operation of a double pump with two motor impeller units of equal power.

Key:

- P_H Main pump
- P_S Peak-load pump
- Q_V Full load volume flow
- Q_T Partial load volume flow
- P_{1V} Full load power consumption
- P_{1T} Partial load power consumption

Investment costs

The total investment costs in heating systems can be reduced by almost 1/4 using "split solutions". Particularly when use is made of double pumps instead of single pumps, with their very high installation costs (Y-pipes, etc.)

Important:

Due to their low outlet velocities, Wilo double pumps are particularly suitable for parallel operation.

Operating costs

Considerable reductions in the operating costs also ensured as a result of the significant savings in current of the low-output "split units", due to the improved utilisation in the partial load range and, in particular, in the low-load range.

Standby

From an operating point of view, there are other advantages, since in the event of a fault in the partial load range or the low-load range, a 100% standby option is available and in the peak-load range, on the few extremely cold days, there is a so-called emergency standby (75%).

Principle of operation

The duty pump and base-load pump are speed-controlled. With the full stabilisation of this unit, i.e. with the nominal pump speed reached and at the start of the peak-load requirement, the peak-load unit is switched on at a fixed speed (nominal speed), while the power of the controlled base-load pump is directly reduced and adjusted to the load point. Resulting pressure fluctuations are relatively minor and in practice have no appreciable effect. During parallel operation, the output of the constant-speed peak-load unit and the controlled base-load unit are added according to the volume flow, which in this operating situation readjusts to the respective peak-load requirement.

The switch-point for cutting in the peak-load pump is determined by means of an internal electronic assessment logic.

Important:

Peak-load switching of Wilo control systems is only possible with control modes according to the differential pressure or differential temperature.

More information on pump controls is available in the catalogue section: "Switchgears and control systems".

Double pump switching

There are two different operating modes for the operation of double pumps:

- **Standby switching** for the individual operation of the duty pump.
- **Peak-load switching** for the parallel operation of both pumps, which are also overridden by a control option on the respective duty pump.

Operating modes

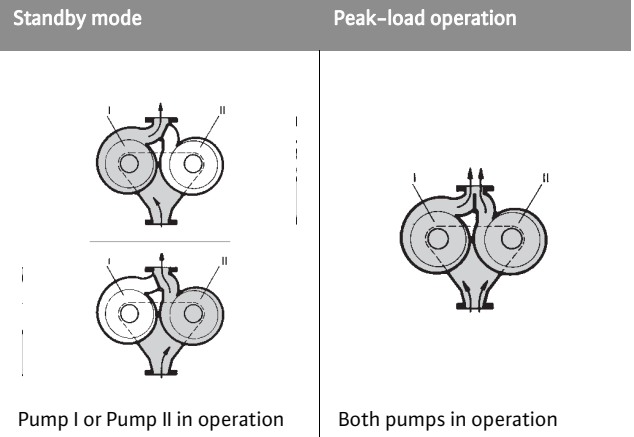

Planning guide

Duty pump uncontrolled

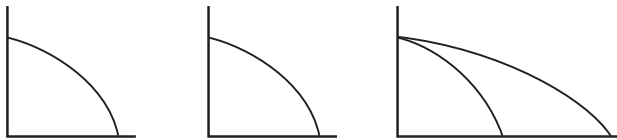

Pump I Pump II Pumps I + II
Investment costs: Lower Higher
Operating costs: High Low

Duty pump controlled via Wilo control system

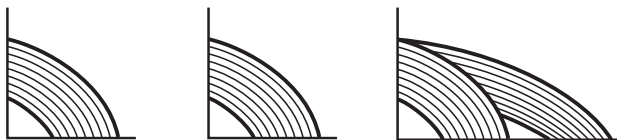

Pump I Pump II Pumps I + II
Investment costs (including control): Higher Lower
Operating costs: Higher Low

Operating functions

Wilo switchgears feature the following operating functions:

A Standby switching, fault-dependent or time-dependent operation switchover pump I <-> pump II.

B Peak-load operation for load-dependent or time-dependent automatic power adjustment by activation or deactivation of the second pump.

C Infinitely variable speed control of the duty pump for load-dependent or time-dependent automatic power adjustment when the second pump is cut in for infinitely variably controlled peak-load operation.

Switchgear	Switching function	Switching function		
		A	B	C
SD series	(standby/cut-in)	•	•	•
S2R 3D	(standby/cut-in)	•	•	•
CR system	(infinitely variable)	•	•	•

S2R 3D/SD series

Switchgears for the automatic control of duty and standby pumps of double units. Automatic fault-actuated switchover from duty to standby pump. With clock timer for regular duty pump and standby pump cycling. **Additional peak-load switching by standard cut-in option for the 2nd pump.**

Short-term parallel operation is integrated into the changeover sequence to avoid the occurrence of valve noise during uncontrolled switchover.

Version in ISO housing, protection class: IP 41. Potential-free contact for collective fault signal.

Connection options to three-phase current 400 V, 50 Hz, or three-phase current 230 V, 50 Hz.

Other voltages and frequencies available as special version on request.

Technical data	
Switchgear type	Motor power [kW]
S2R 3D	0.37 - 3
SD 5.5	4 - 5.5
SD 9	7.5 - 9
SD 18.5	11 - 18.5
SD 30	22 - 30
SD 37	37

Planning guide for Wilo norm pumps: installation of pumps on a base

The correct selection of the single pump base version is one of the decisive factors for low-noise pump operation.

A direct and rigid connection between the pump unit and the base block is recommended for the purpose of increasing the mass capable of absorbing vibrations and for compensating uncompensated gravitational forces. However, vibration-insulated installation also requires an elastic intermediate layer for separating the base block itself from the building structure.

The type and the material of the intermediate layer to be selected depends on a variety of different factors (and areas of responsibility), including speed, unit mass and centre of gravity, constructional design (architect) and the development of other influences caused by pipes, etc. (planning engineers/installation company).

It is recommended that a qualified building acoustics specialist is given the task of configuration and design where necessary - taking into account all constructionally and acoustically relevant criteria.

The outer dimensions of the base block should be approximately 15 to 20 cm greater than the outer dimensions of the baseplate of the pump unit (see Fig.).

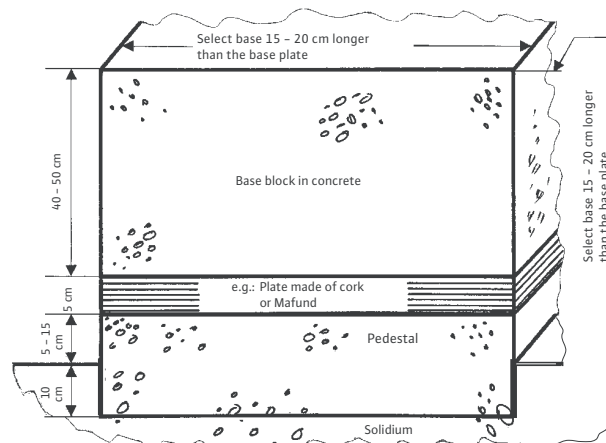

Care should be taken with the base pedestal design, i.e. that no acoustic bridges are formed by plaster, tiles or auxiliary constructions that would nullify or sharply reduce the sound insulation effect.

Planning engineers and installation companies must take care to ensure that the pipe connections to the pump are completely stress-free in their design and unable to exert any gravitational or vibration influences on the pump housing whatsoever. Fixed points with no connection to the base are recommended for the pipe connections on the suction and pressure sides of the pump.

After the installation of Wilo norm pumps, customers are responsible for aligning the baseplate and the pump mounted on it with the coupling and the motor.

It is recommended that the pump be commissioned by Wilo after-sales service.

A spacer is always recommended for motors > 55 kW.

Anticipated noise levels for Wilo norm pumps (guideline values)

Motor power P ₂ (kW)	Sound-pressure level (dB) ¹⁾ Pump with motor		
	6-pole pumps	4-pole pumps	2-pole pumps
< 0.55	–	63	64
0.75	–	63	67
1.1	–	65	67
1.5	–	66	70
2.2	–	68	71
3	–	70	74
4	–	71	75
5.5	–	72	83
7.5	–	73	83
11	–	74	84
15	–	75	85
18.5	–	76	85
22	–	77	85
30	–	80	93
37	–	80	93
45	–	80	93
55	79.5	82	95
75	82.5	83	95
90	82.5	85	95
110	82.5	86	95
132	84.0	86	95
160	86.0	86	96
185	86.0	87	96
200	86.0	88	96
250	87.5	89	–
315	87.5	89	–
355	92.5	94	–
400	92.5	94	–
450	93.5	94	–

¹⁾Spatial mean value of sound pressure levels on a square measuring surface at a distance of 1 m from the surface of the motor

Pump control

When Wilo pumps are operated with control devices or module accessories, the electrical operating conditions in accordance with VDE 0160 are to be complied with.

When operating glandless and glanded pumps with brands of frequency converters other than those supplied by Wilo, output filters

for reducing motor noise and for preventing harmful voltage peaks are to be used and the following limit values are to be complied with:

Glandless pumps with P₂ ≤ 1.3 kW and glanded pumps with P₂ ≤ 1.1 kW

- Rate of voltage rise du/dt < 500 V/μs
- Voltage peaks \hat{u} < 650 V

For the noise reduction of glandless pump motors, it is recommended that sine filters (LC filters) be used rather than du/dt filters (RC filters).

Glanded pumps with P₂ > 1.1 kW

- Rate of voltage rise du/dt < 500 V/μs
- Voltage peaks \hat{u} < 850 V

Installations with long cable lengths (l > 10 m) between converter and motor may increase the du/dt and \hat{u} levels (resonance). The same applies to operation with more than 4 units at one power supply source. The output filters must be selected as recommended by the converter manufacturer or filter supplier.

The pumps must be operated at a maximum of 95% of their nominal speed if the frequency converter causes motor losses. The following limit values at the pump connection terminals must not be fallen short of if glandless pumps of the TOP-S/-SD, TOP-D and TOP-Z series are operated with a frequency converter: U_{min} = 150 V f_{min} = 30 Hz

Monobloc pumps

Monobloc pumps, special monobloc pumps

Series overview

Series: Wilo-BAC

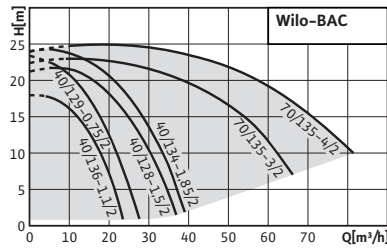

> Design

Glanded pump in block design with threaded connection or Victaulic connection

> Application

For pumping water-glycol mixtures with 20 - 40 vol.% glycol proportion



Series: Wilo-CronoBloc-BL

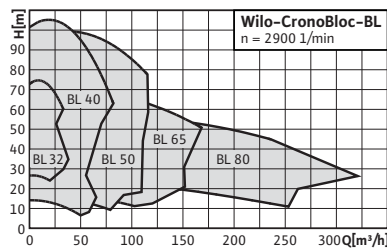

> Design

Glanded pump in block design with flange connection

> Application

For pumping cold and hot water (in accordance with VDI 2035) without abrasive substances in heating, cold water and cooling water systems

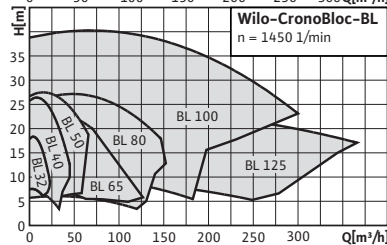

Series overview

Series: Wilo-BAC

> Special features/product benefits

- Reduced life cycle costs due to optimised efficiency
- High corrosion protection due to cathaphoretic coating of cast iron components
- Bidirectional, force-flushed mechanical seal, worldwide high availability of standard motors (according to Wilo specification) and mechanical seals
- Pump housing in plastic design
- Version with Victaulic or threaded connection (BAC 70/135... with Victaulic connection only)

> More information

• Planning guide	6
• Technical data	16
• Series description	18
• Pump curves.....	20
• Terminal diagrams, motor data ...	21
• Dimensions, weights	22
• Switchgears and control devices ...	160

Series: Wilo-CronoBloc-BL

> Special features/product benefits

- Reduced life cycle costs due to optimised efficiency
- High corrosion protection due to cathaphoretic coating of cast iron components
- Standard condensate drainage holes in the motor housings
- Application benefits in air-conditioning and cooling systems due to direct condensate drainage by means of optimised lantern design
- Bidirectional mechanical seal with forced flushing
- High worldwide obtainability of standard motors (according to Wilo specifications) and mechanical seals
- Meets user requirements due to performance and main dimensions in accordance with EN 733 (DIN for norm pumps)

> More information

• Planning guide	6
• Technical data	25
• Series description	23
• Pump curves.....	31
• Terminal diagrams, motor data ...	36
• Dimensions, weights	37
• Switchgears and control devices ...	160

Monobloc pumps

Single pumps (heating, air-conditioning, cooling and industry)

Technical data Wilo-BAC		
	Wilo- BAC ...-S (threaded connection)	Wilo- BAC ...-R (Victaulic coupling)
Approved fluids (other fluids on request)		
Heating water (in accordance with VDI 2035)		–
Water-glycol mixtures (for 20–40 vol.% glycol and fluid temperature ≤ 40 °C)		•
Cooling and cold water		–
Heat transfer oil		–
Permitted field of application		
Standard version for operating pressure, p_{\max} [bar]		6
Temperature range [°C]		–15 to +60
Max. ambient temperature [°C]		40
Installation in closed buildings		•
Outdoor installation		–
Pipe connections		
Nominal connection diameters DN	on suction side: G2 on pressure side: G1 ¹ / ₂	on suction side: Ø 60.3 (BAC 40...); Ø 73.0 (BAC 70...) on pressure side: Ø 48.3 (BAC 40...); Ø 73.0 (BAC 70...)
Flanges (according to EN 1092-2)		–
Flange with pressure-measurement connections		–
Materials		
Pump housing		PA 6.6 50% GF
Lantern		PA 6.6 50% GF
Impeller (standard)		GFN 3
Impeller (special version)		–
Pump shaft		X30Cr13
Mechanical seal		Synthetic resin impregnated carbon/aluminium oxide/EPDM
Other mechanical seals		–
Electrical connection		
Mains connection		3~400 V, 50 Hz
Speed range [rpm]		2900
Motor/electronics		
Integrated full motor protection		Special version with PTC thermistor sensor (TRS) at additional charge
Protection class		IP 54
Insulation class		F
Emitted interference		
Interference resistance		
Residual-current protection device (RCD)		
Motor protection required onsite		•
Speed control		–

Monobloc pumps

Single pumps (heating, air-conditioning, cooling and industry)



Technical data Wilo-BAC

	Wilo- BAC ...-S (threaded connection)	Wilo- BAC ...-R (Victaulic coupling)
Motor winding up to 3 kW	230 V Δ /400 V Y, 50 Hz	
Motor winding from 4 kW	400 V Δ /690 V Y, 50 Hz	
Installation options		
Support-bracket mounting	•	

• = available, - = not available

Monobloc pumps

Single pumps (heating, air-conditioning, cooling and industry)

Series description Wilo-BAC



Materials

- Pump housing and lantern: PA 6.6 50% GF
- Impeller: GFN 3I
- Shaft: X30Cr13
- Mechanical seal: Synthetic resin impregnated carbon/aluminium oxide/EPDM

Description/design

Single-stage low-pressure centrifugal pump in block design, with axial suction port and radially arranged pressure port.

Design

Glanded pump in block design with threaded connection or Victaulic connection

Application

For pumping water-glycol mixtures with 20 – 40 vol.% glycol proportion

Scope of delivery

- Pump
- Installation and operating instructions

Type key

Example	BAC 40/128-1.5/2-S
BAC	Monobloc pump for cooling and air-conditioning applications
40/128	Type of impeller
1.5	Nominal motor power P_2 in kW
2	Number of poles
S	Threaded connection
R	Victaulic connection

Technical data

- Permissible temperature range: -15°C to $+60^{\circ}\text{C}$
- Mains connection: 3~400 V, 50 Hz
- Protection class: 54
- Nominal diameter: G2/G 1½ (type S) or Victaulic connection 60.3/48.3 mm (type R)
- Max. operating pressure: 6 bar

Special features/product benefits

- Reduced life cycle costs due to optimised efficiency
- High corrosion protection due to cathaphoretic coating of cast iron components
- Bidirectional, force-flushed mechanical seal, worldwide high availability of standard motors (according to Wilo specification) and mechanical seals
- Pump housing in plastic design
- Version with Victaulic or threaded connection (BAC 70/135... with Victaulic connection only)

Monobloc pumps

Single pumps (heating, air-conditioning, cooling and industry)



Series description Wilo-BAC

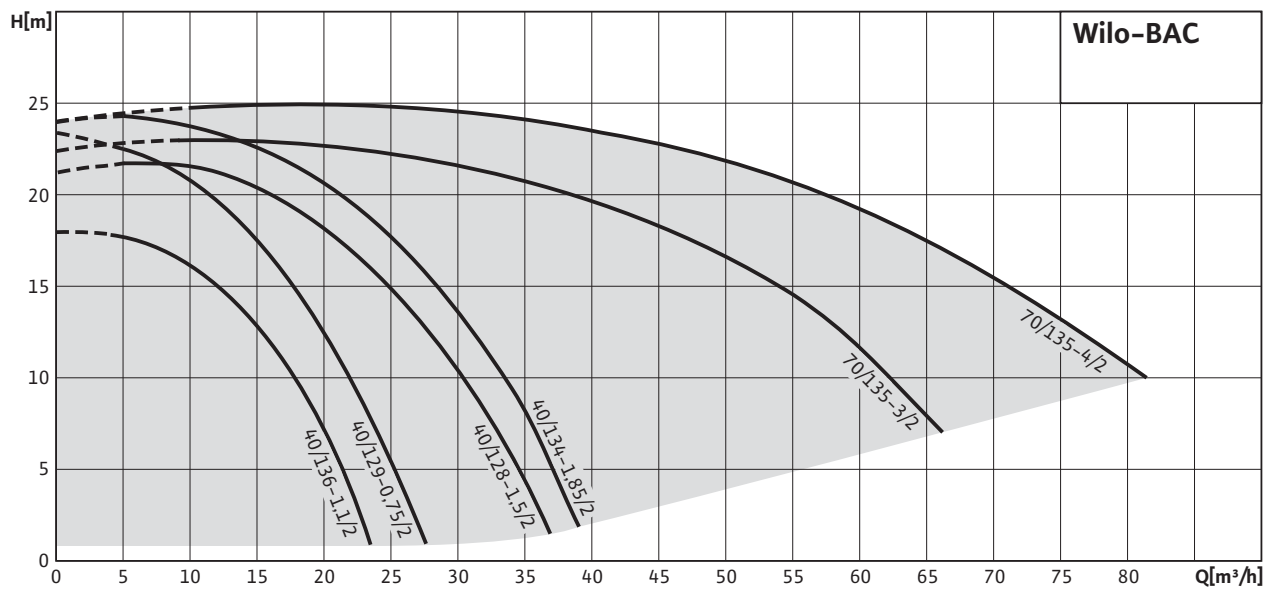

Monobloc pumps

Single pumps (heating, air-conditioning, cooling and industry)

Pump curves Wilo-BAC

Wilo-BAC 40...

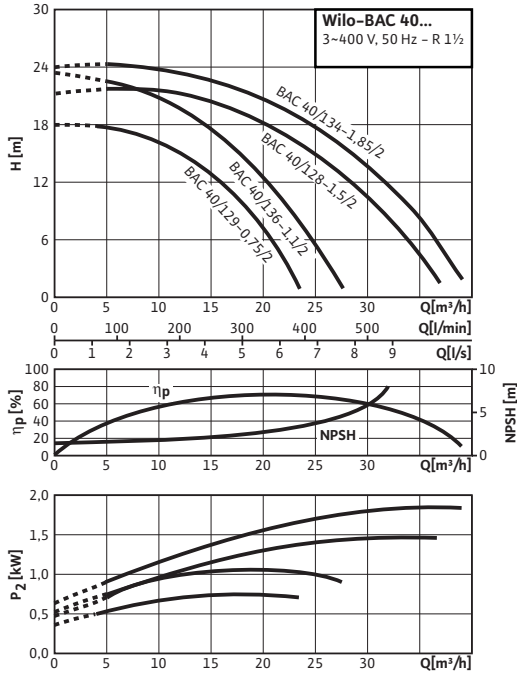

Pump curve for water 20 °C - ISO 2548 Class C

Wilo-BAC 70...

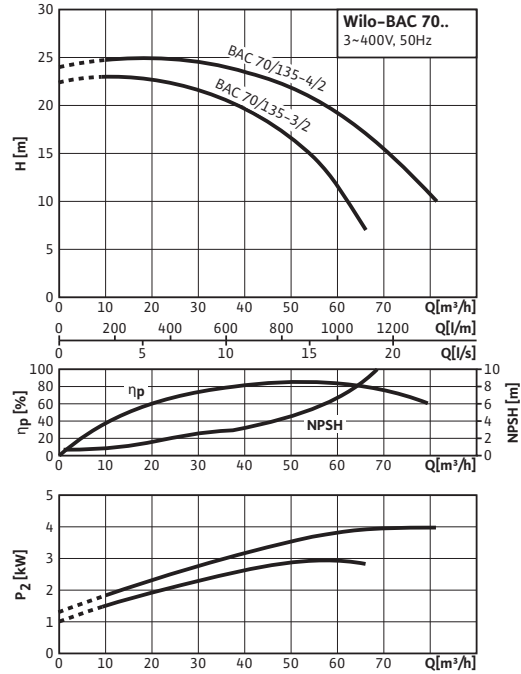

Pump curve for water 20 °C - ISO 2548 Class C

Monobloc pumps

Single pumps (heating, air-conditioning, cooling and industry)



Terminal diagram, motor data Wilo-BAC

Terminal diagram

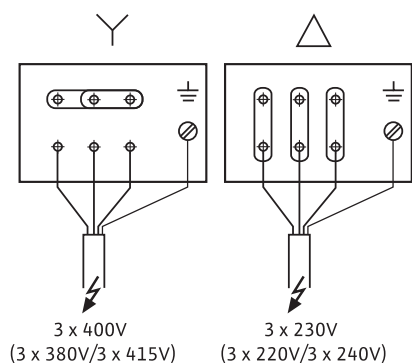

Motor data

Wilo-BAC ...	Nominal motor power	Nominal current approx.	Nominal current	Screwed cable connection
	P_2	$I_{N1 \sim 230 V}$	$I_{N3 \sim 400 V}$	-
	[kW]	[A]		[PG]
40/128-1.50/2-S	1.5	5.9	3.9	1x13.5
40/128-1.50/2-R	1.5	5.9	3.9	1x13.5
40/129-0.75/2-S	0.75	3.22	1.85	1x11
40/129-0.75/2-R	0.75	3.22	1.85	1x11
40/134-1.85/2-S	1.85	8.02	4.61	1x13.5
40/134-1.85/2-R	1.85	8.02	4.61	1x13.5
40/136-1.10/2-S	1.1	4.64	2.67	1x11
40/136-1.10/2-R	1.1	4.64	2.67	1x11
70/135-3.0/2-S	3	11	6.4	1x13.5
70/135-4.0/2-S	4	14.3	8.3	1x13.5

Monobloc pumps

Single pumps (heating, air-conditioning, cooling and industry)

Dimensions, weights Wilo-BAC

Dimension drawing A

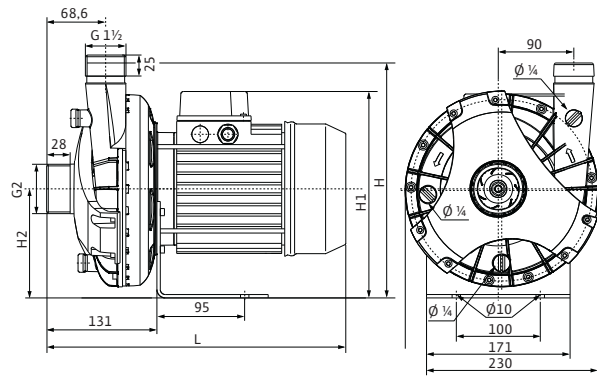

Dimension drawing B

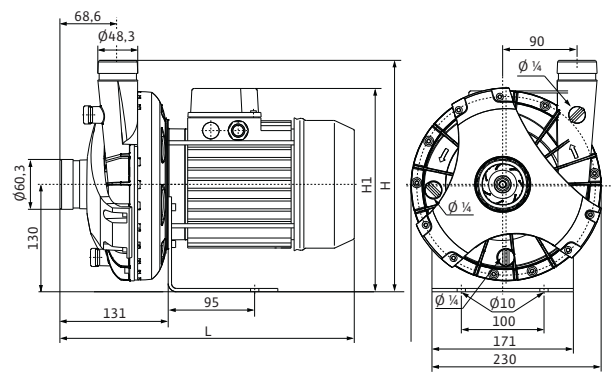

Dimension drawing C

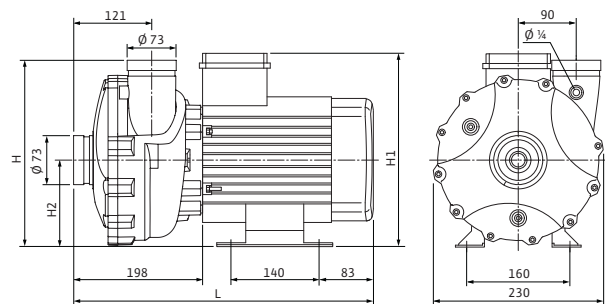

Dimensions, weights

Wilo-BAC ...	Dimensions				Weight approx.	Dimension drawing
	H	H ₁	H ₂	L	M	—
	[mm]				[kg]	—
40/128-1.50/2-S	280	246	130	356	13.8	A
40/128-1.50/2-R	280	246	130	356	13.8	B
40/129-0.75/2-S	280	235	130	347	10.4	A
40/129-0.75/2-R	280	235	130	347	10.4	B
40/134-1.85/2-S	280	246	130	356	15.4	A
40/134-1.85/2-R	280	246	130	356	15.4	B
40/136-1.10/2-S	280	235	130	347	12.7	A
40/136-1.10/2-R	280	235	130	347	12.7	B
70/135-3.0/2-S	291	300	135	463	24.5	C
70/135-4.0/2-S	291	300	135	463	26.5	C

Monobloc pumps

Single pumps (heating, air-conditioning, cooling and industry)



Series description Wilo-CronoBloc-BL



Materials

- Pump housing and lantern: Standard: EN-GJL-250; optional: Spheroidal cast iron EN-GJS-400-18-LT
- Impeller: Standard: EN-GJL-200; Special version: Red brass G-CuSn10
- Shaft: 1.4122
- Mechanical seal: AQ1EGG; other mechanical seals on request

Description/design

- Single-stage low-pressure centrifugal pump in block design, with axial suction port and radially arranged pressure port with
- Mechanical seal
 - Flange connection with pressure measuring connection R $\frac{1}{8}$
 - Lantern
 - Coupling
 - IEC standard motor

Design

Glanded pump in block design with flange connection

Application

For pumping cold and hot water (in accordance with VDI 2035) without abrasive substances in heating, cold water and cooling water systems

Scope of delivery

- Pump
- Installation and operating instructions

Type key

Example	BL 40/160-4/2
BL	Monobloc pump
40	Nominal diameter DN of the pipe connection (pressure port)
160	Nominal impeller diameter
4	Nominal motor power P_2 in kW
2	Number of poles

Technical data

- Permissible temperature range: -20°C to $+140^{\circ}\text{C}$
- Mains connection: 3~400 V, 50 Hz
- Protection class: IP 55
- Nominal diameter: DN 32 to DN 150
- Max. operating pressure: 16 bar

Special features/product benefits

- Reduced life cycle costs due to optimised efficiency
- High corrosion protection due to cathoretic coating of cast iron components
- Standard condensate drainage holes in the motor housings
- Application benefits in air-conditioning and cooling systems due to direct condensate drainage by means of optimised lantern design
- Bidirectional mechanical seal with forced flushing
- High worldwide obtainability of standard motors (according to Wilo specifications) and mechanical seals
- Meets user requirements due to performance and main dimensions in accordance with EN 733 (DIN for norm pumps)

Monobloc pumps

Single pumps (heating, air-conditioning, cooling and industry)

Series description Wilo-CronoBloc-BL

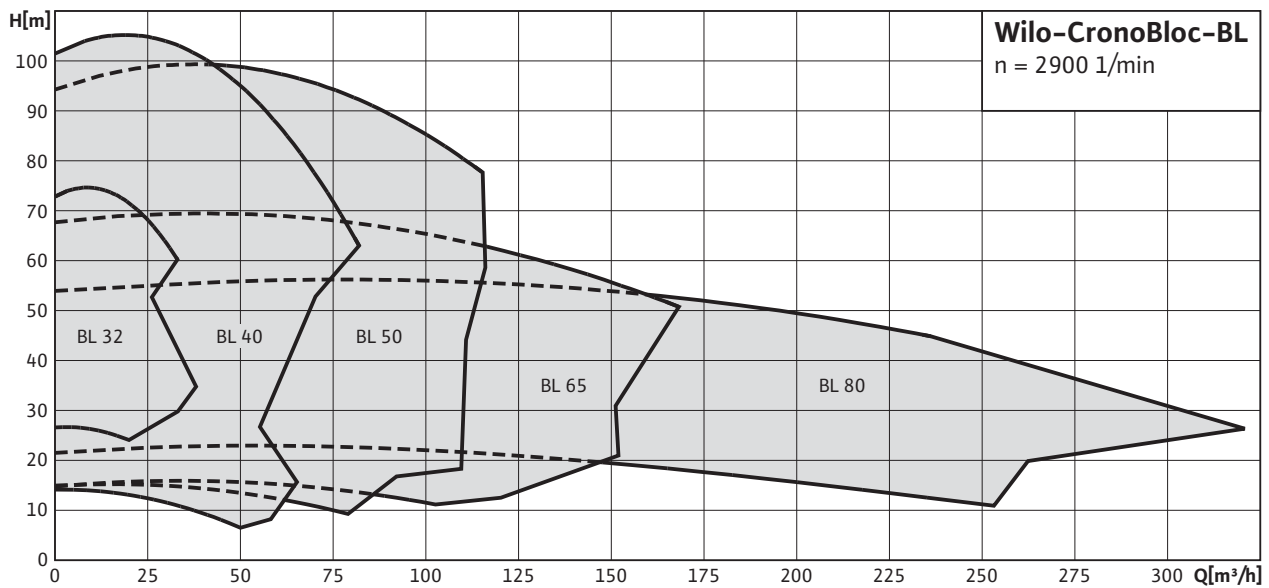
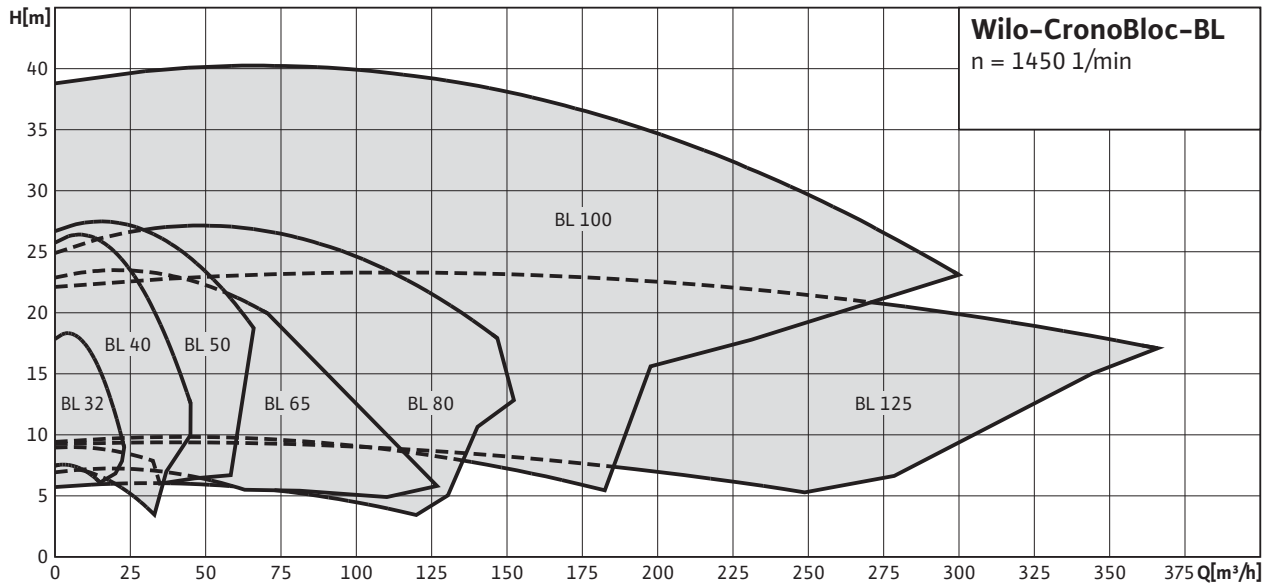

Monobloc pumps

Single pumps (heating, air-conditioning, cooling and industry)



Technical data Wilo-CronoBloc-BL

Wilo- CronoBloc-BL	
Approved fluids (other fluids on request)	
Heating water (in accordance with VDI 2035)	•
Water-glycol mixtures (for 20-40 vol.% glycol and fluid temperature ≤ 40 °C)	•
Cooling and cold water	•
Heat transfer oil	Special version at additional charge
Permitted field of application	
Standard version for operating pressure, p_{max} [bar]	13 (up to +140°C) 16 (up to +120°C)
Temperature range [°C]	- 20 to + 140
Max. ambient temperature [°C]	40
Installation in closed buildings	•
Outdoor installation	Special version at additional charge
Pipe connections	
Nominal connection diameters DN	32-125
Flanges (according to EN 1092-2)	PN 16
Flange with pressure-measurement connections	R 1/8
Materials	
Pump housing	EN-GJL-250 (EN-GJS-400 on request)
Lantern	EN-GJL-250 (EN-GJS-400 on request)
Impeller (standard)	EN-GJL-200
Impeller (special version)	G-CuSn10
Pump shaft	1.4122
Mechanical seal	AQEGG
other mechanical seals	On request (at additional charge)
Electrical connection	
Mains connection	3~400 V, 50 Hz (other on request)
Speed range [rpm]	1450/2900 1450-2900
Motor/electronics	
Integrated full motor protection	Special version with PTC thermistor sensor (TRS) at additional charge
Protection class	IP 55
Insulation class	F
Speed control	Wilo control system
Motor winding up to 3 kW	230 V Δ/400 V Y, 50 Hz
Motor winding from 4 kW	400 V Δ/690 V Y, 50 Hz

Monobloc pumps

Single pumps (heating, air-conditioning, cooling and industry)

Technical data Wilo-CronoBloc-BL

Wilo- CronoBloc-BL

Installation options

Support-bracket mounting

•

• = available, - = not available

Monobloc pumps

Single pumps (heating, air-conditioning, cooling and industry)



Pump curves Wilo-CronoBloc-BL

Wilo-CronoBloc-BL 32/140-2,2/2 – 32/170-5,5/2

Speed 2900 rpm

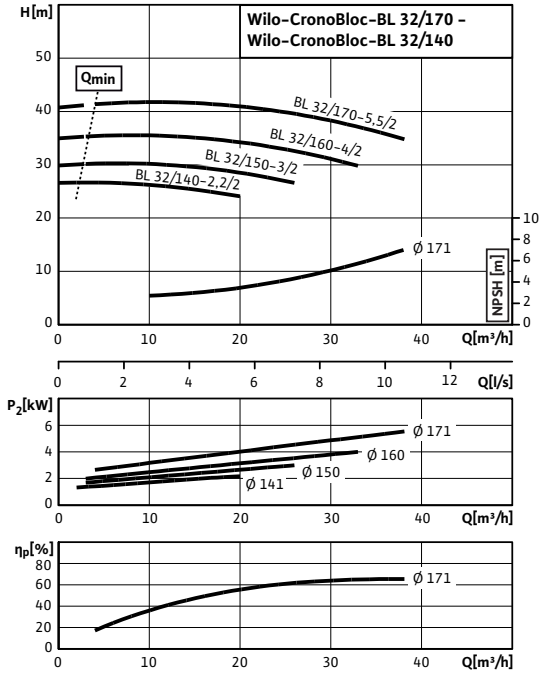

Wilo-CronoBloc-BL 32/210-7,5/2 – 32/220-11/2

Speed 2900 rpm

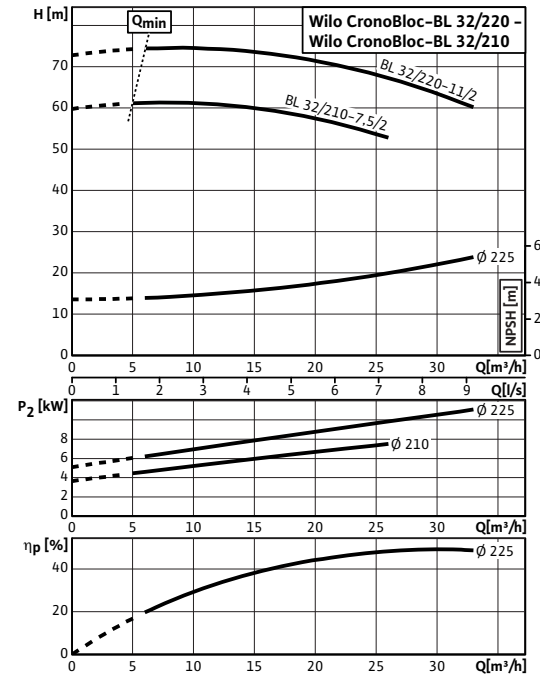

Wilo-CronoBloc-BL 40/110-1,5/2 – 40/140-4/2

Speed 2900 rpm

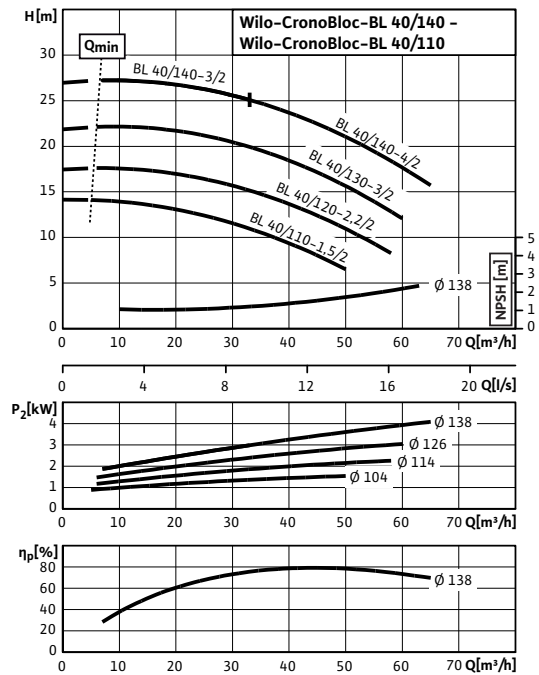

Wilo-CronoBloc-BL 40/160-5,5/2 – 40/170-7,5/2

Speed 2900 rpm

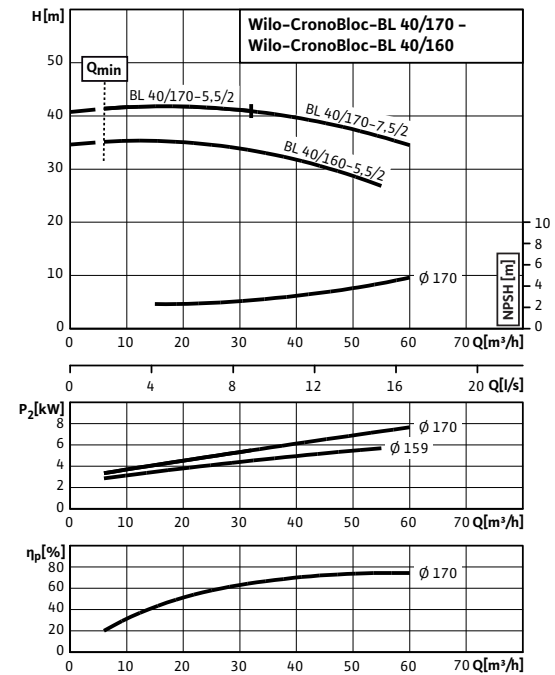

Monobloc pumps

Single pumps (heating, air-conditioning, cooling and industry)

Pump curves Wilo-CronoBloc-BL

Wilo-CronoBloc-BL 40/180-7,5/2 - 40/220-15/2

Speed 2900 rpm

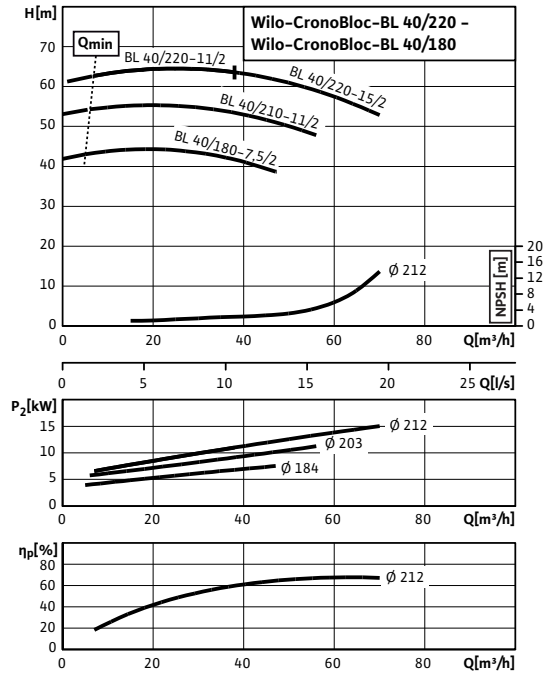

Wilo-CronoBloc-BL 40/250-22/2 - 40/270-30/2

Speed 2900 rpm

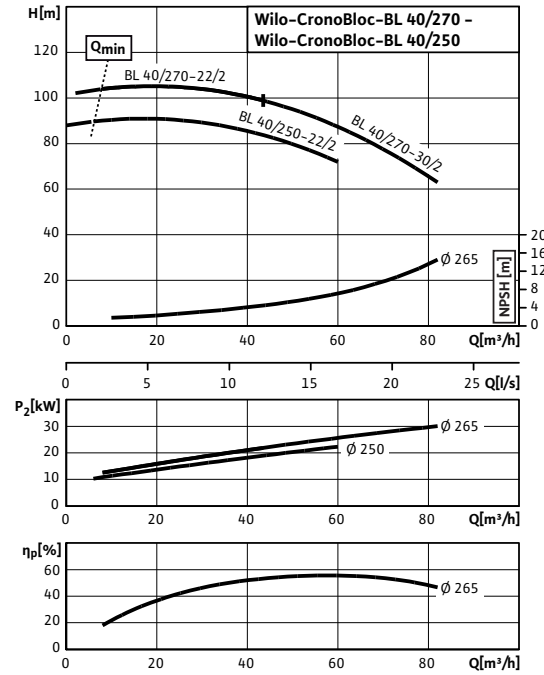

Wilo-CronoBloc-BL 50/110-3/2 - 50/140-7,5/2

Speed 2900 rpm

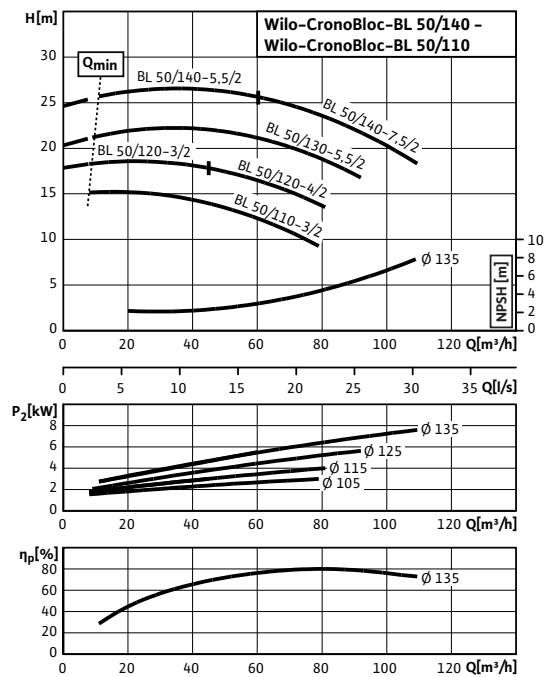

Wilo-CronoBloc-BL 50/150-5,5/2 - 50/170-11/2

Speed 2900 rpm

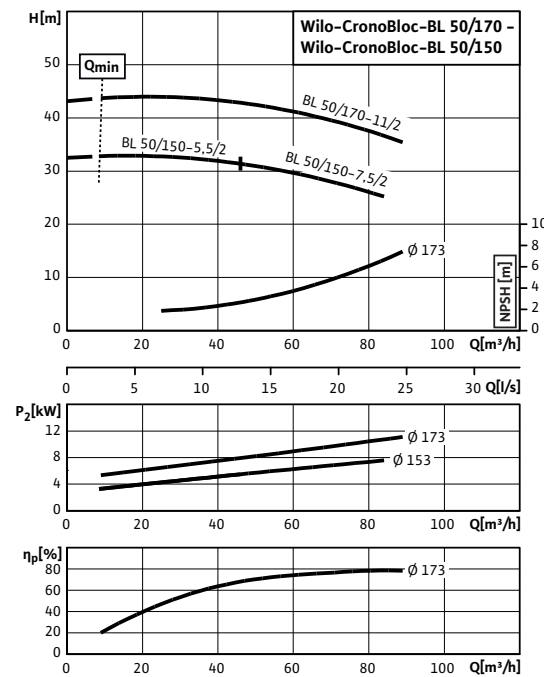

Monobloc pumps

Single pumps (heating, air-conditioning, cooling and industry)



Pump curves Wilo-CronoBloc-BL

Wilo-CronoBloc-BL 50/200-11/2 - 50/220-22/2

Speed 2900 rpm

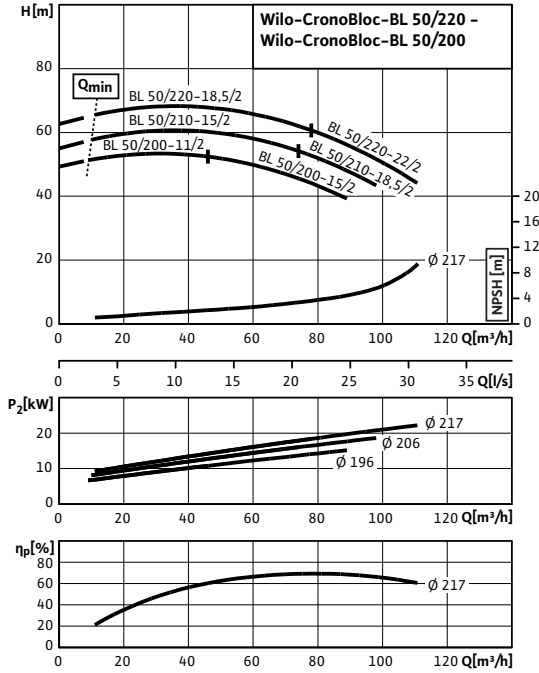

Wilo-CronoBloc-BL 50/240-30/2 - 50/260-37/2

Speed 2900 rpm

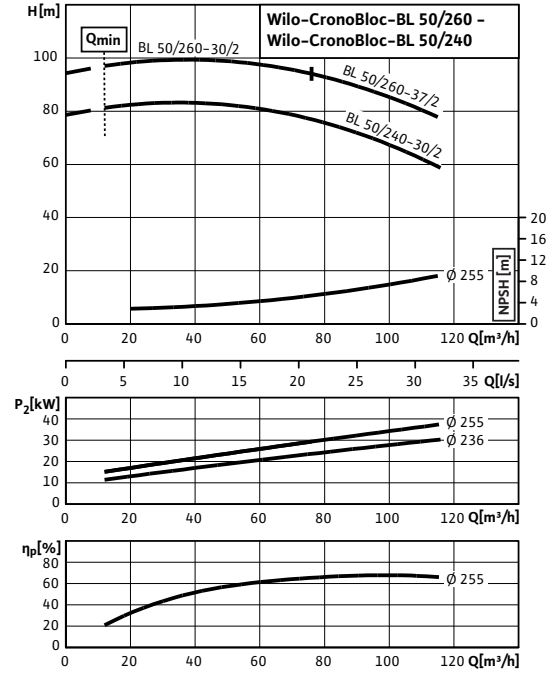

Wilo-CronoBloc-BL 65/120-4/2 - 65/140-7.5/2

Speed 2900 rpm

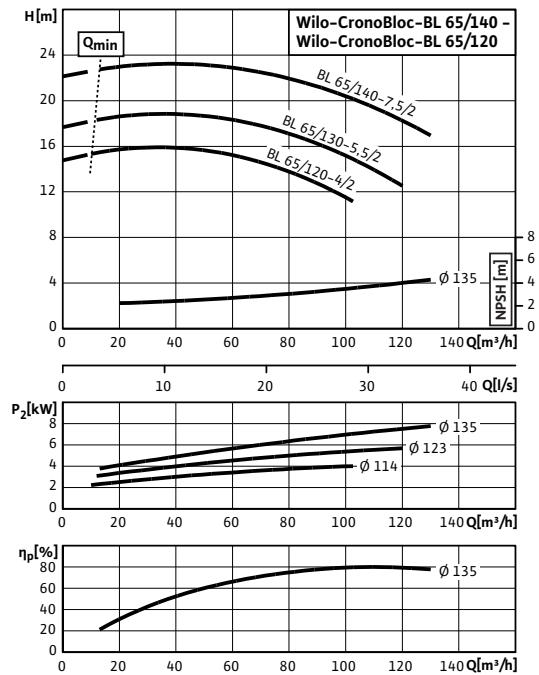

Wilo-CronoBloc-BL 65/160-11/2 - 65/170-15/2

Speed 2900 rpm

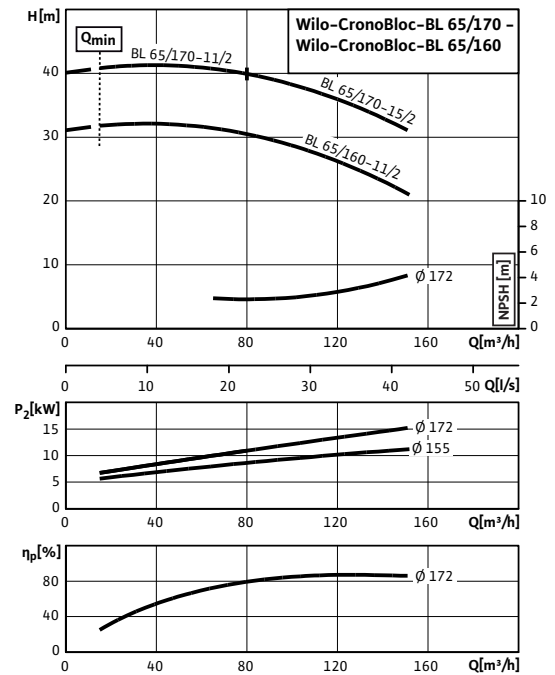

Monobloc pumps

Single pumps (heating, air-conditioning, cooling and industry)

Pump curves Wilo-CronoBloc-BL

Wilo-CronoBloc-BL 65/190-15/2 - 65/220-30/2

Speed 2900 rpm

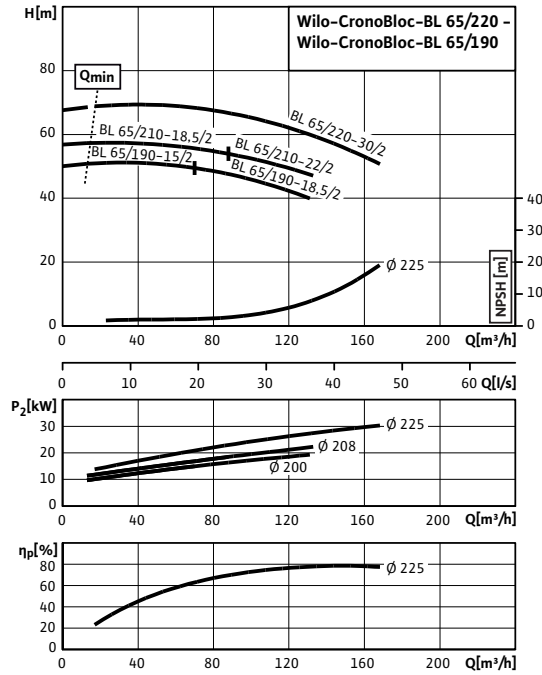

Wilo-CronoBloc-BL 80/145-11/2 - 80/170-30/2

Speed 2900 rpm

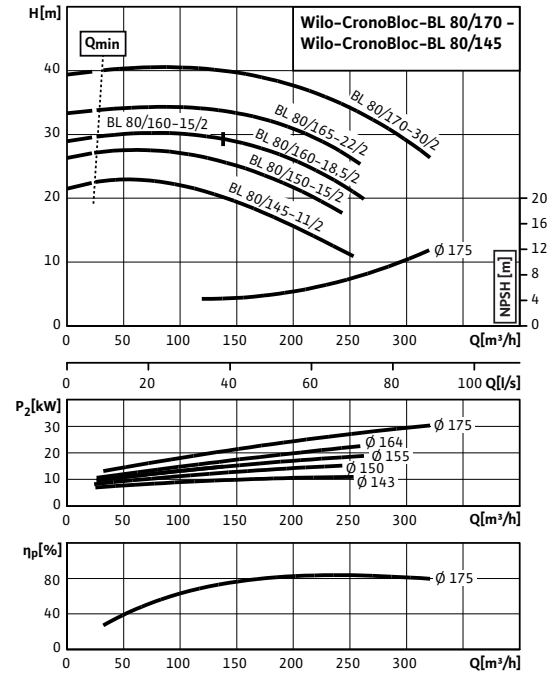

Wilo-CronoBloc-BL 80/200-30/2 - 80/210-37/2

Speed 2900 rpm

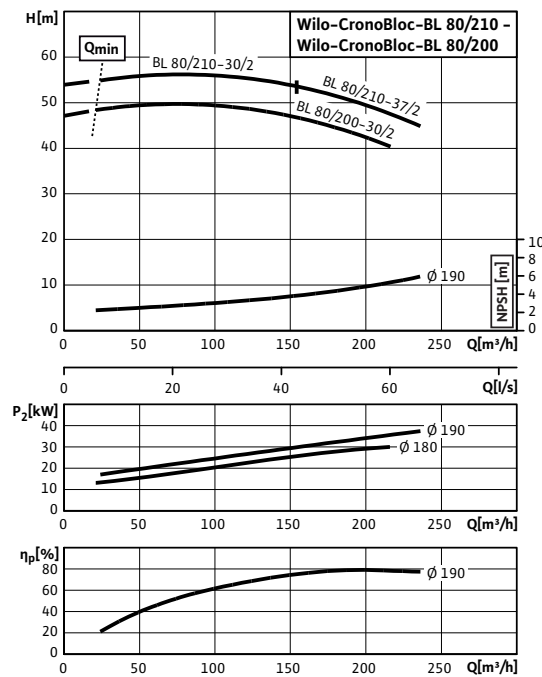

Monobloc pumps

Single pumps (heating, air-conditioning, cooling and industry)



Pump curves Wilo-CronoBloc-BL

Wilo-CronoBloc-BL 32/150-0,37/4 - 32/170-0,75/4

Speed 1450 rpm

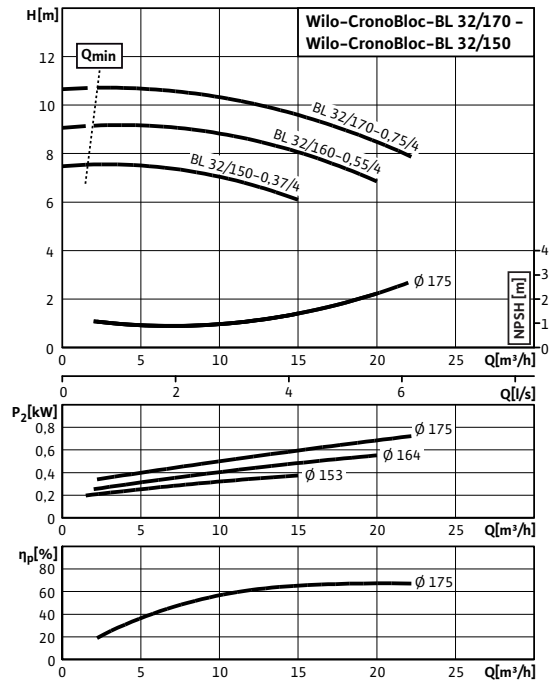

Wilo-CronoBloc-BL 32/210-1,1/4 - 32/220-1,5/4

Speed 1450 rpm

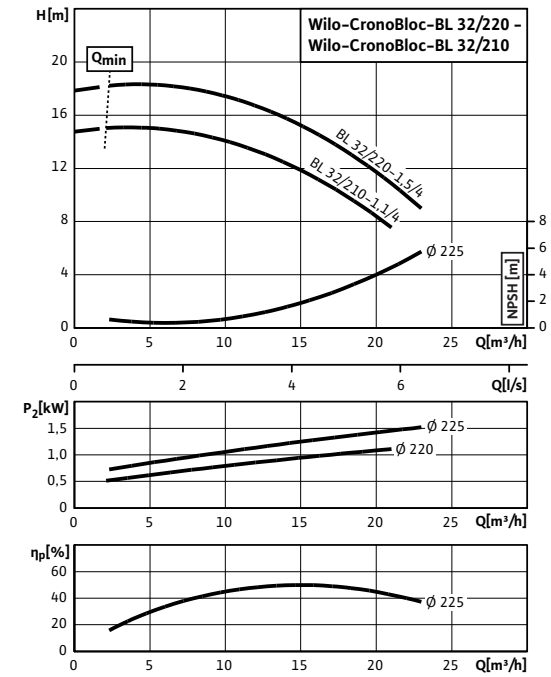

Wilo-CronoBloc-BL 40/150-0,55/4 - 40/170-1,1/4

Speed 1450 rpm

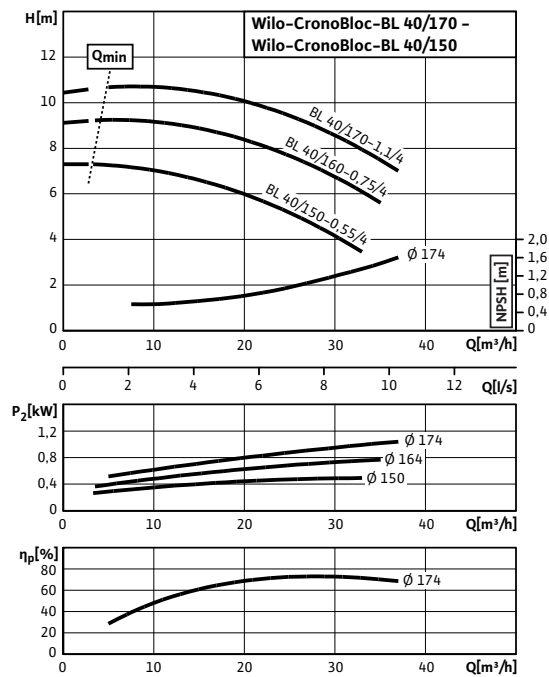

Wilo-CronoBloc-BL 40/210-1,5/4 - 40/220-2,2/4

Speed 1450 rpm

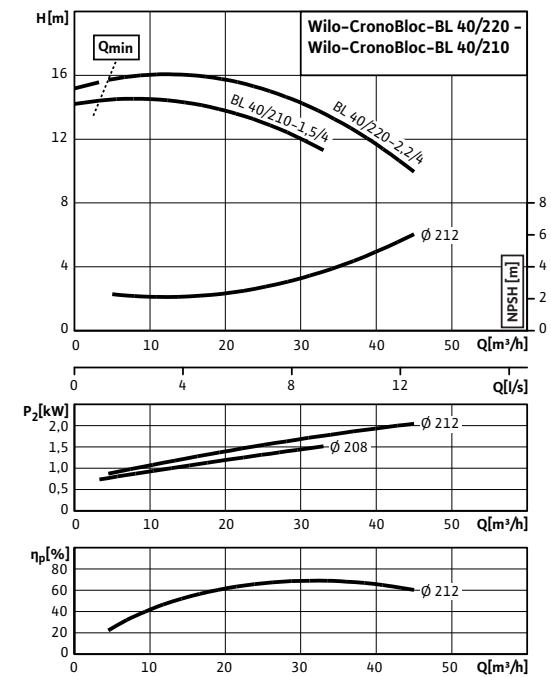

Monobloc pumps

Single pumps (heating, air-conditioning, cooling and industry)

Pump curves Wilo-CronoBloc-BL

Wilo-CronoBloc-BL 40/260-3/4 - 40/270-4/4

Speed 1450 rpm

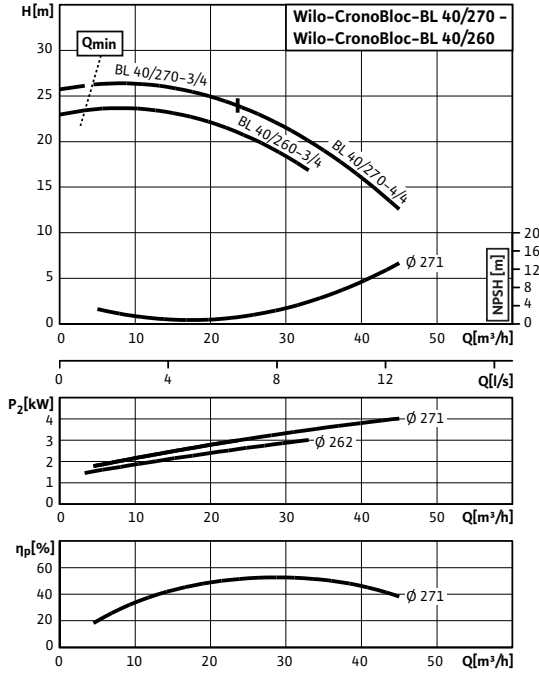

Wilo-CronoBloc-BL 50/160-1,1/4 - 50/170-1,5/4

Speed 1450 rpm

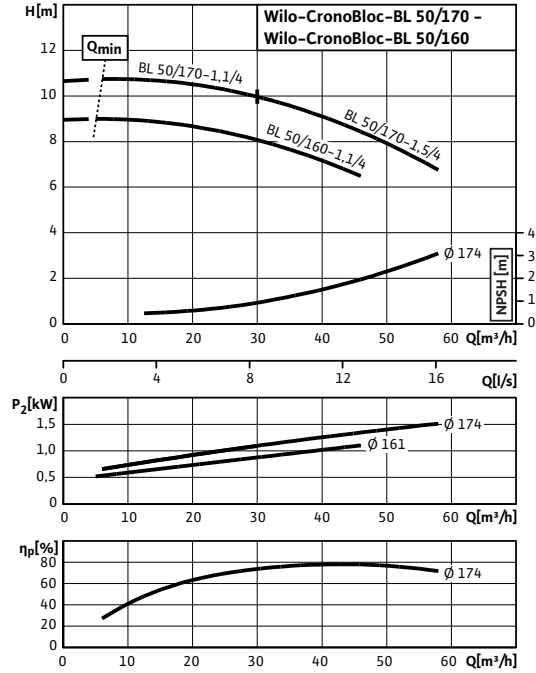

Wilo-CronoBloc-BL 50/200-2,2/4 - 50/220-3/4

Speed 1450 rpm

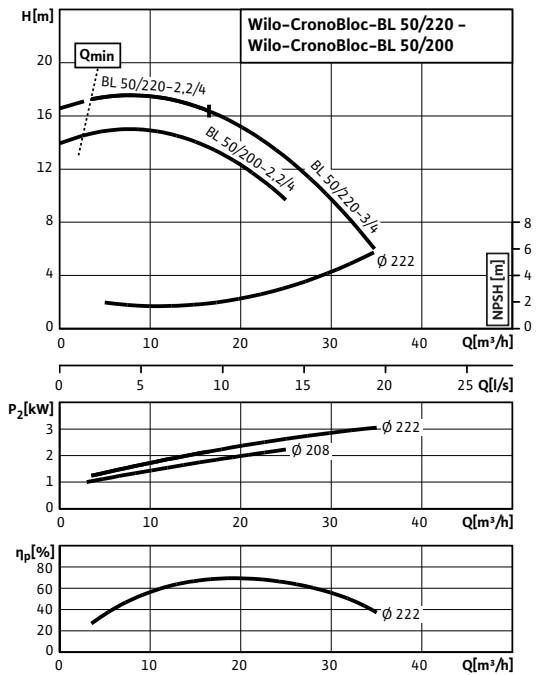

Wilo-CronoBloc-BL 50/250-3/4 - 50/270-5,5/4

Speed 1450 rpm

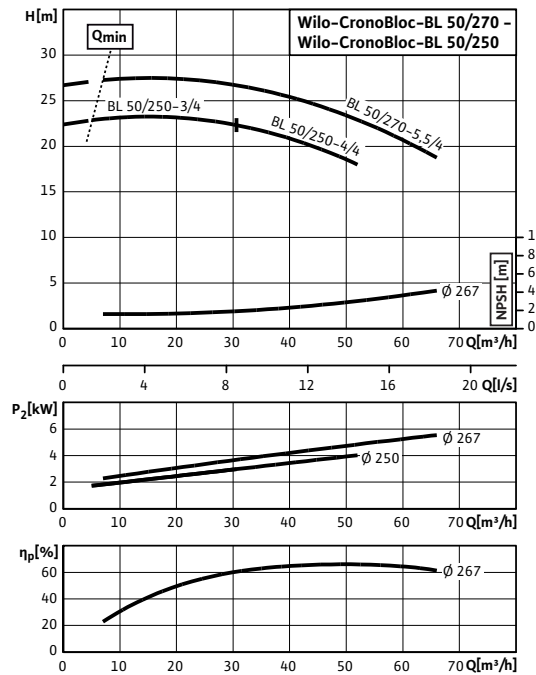

Monobloc pumps

Single pumps (heating, air-conditioning, cooling and industry)



Pump curves Wilo-CronoBloc-BL

Wilo-CronoBloc-BL 65/150-1,1/4 - 65/170-2,2/4

Speed 1450 rpm

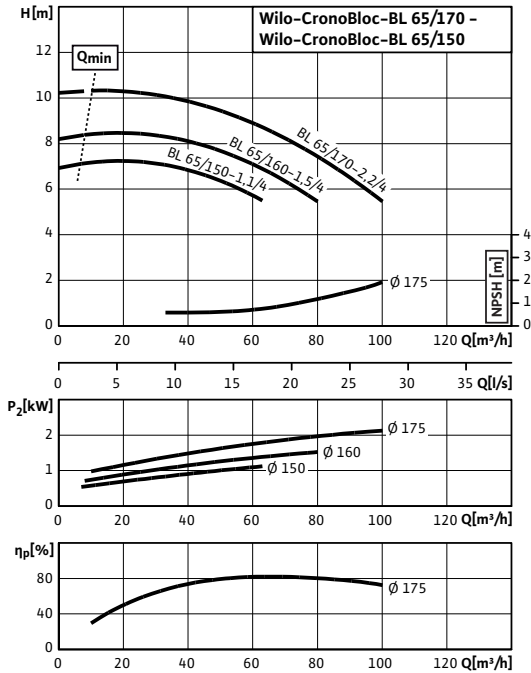

Wilo-CronoBloc-BL 65/210-3/4 - 65/220-4/4

Speed 1450 rpm

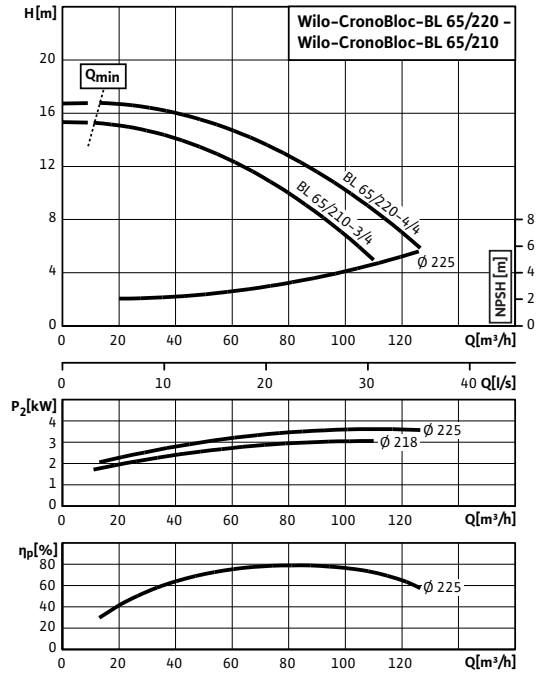

Wilo-CronoBloc-BL 65/270-5,5/4

Speed 1450 rpm

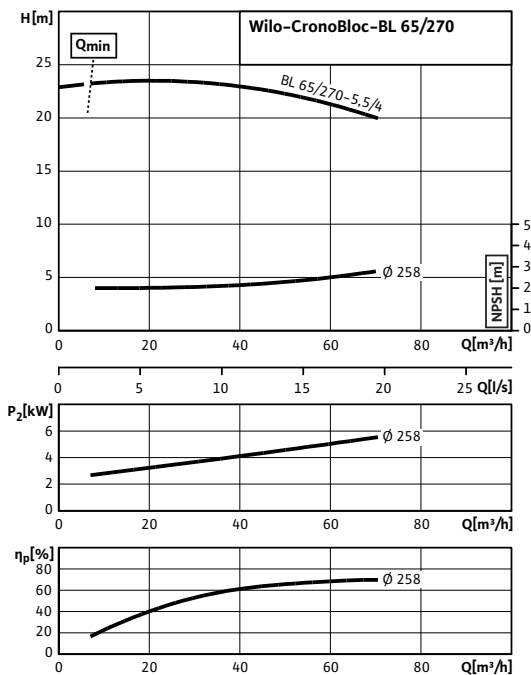

Wilo-CronoBloc-BL 80/150-1,5/4 - 80/170-3/4

Speed 1450 rpm

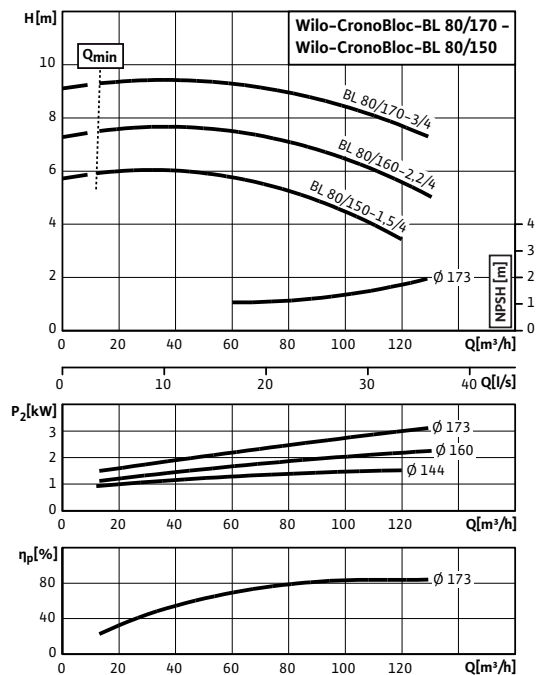

Monobloc pumps

Single pumps (heating, air-conditioning, cooling and industry)

Pump curves Wilo-CronoBloc-BL

Wilo-CronoBloc-BL 80/200-3/4 - 80/220-5,5/4

Speed 1450 rpm

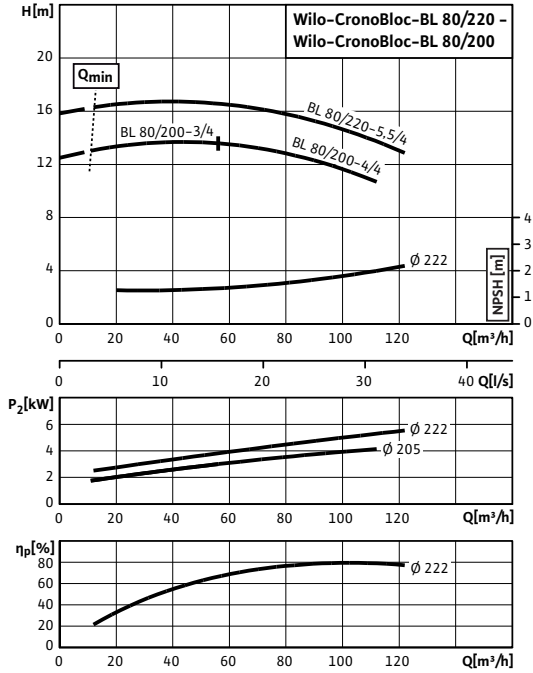

Wilo-CronoBloc-BL 80/250-5,5/4 - 80/270-11/4

Speed 1450 rpm

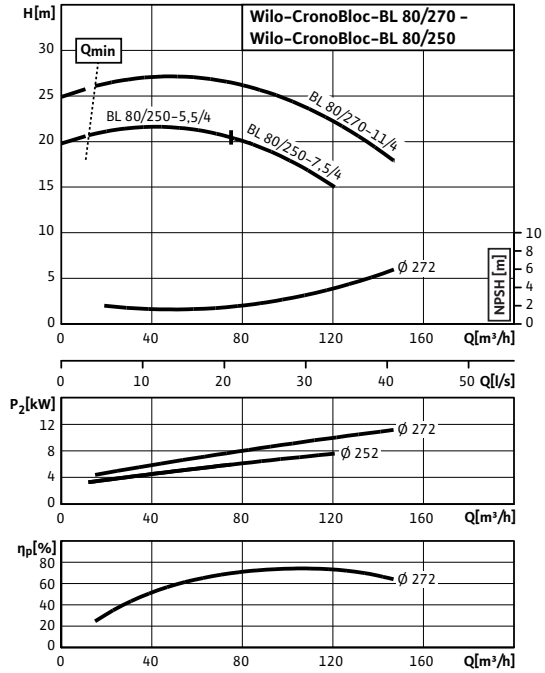

Wilo-CronoBloc-BL 100/180-4/4 - 100/220-7,5/4

Speed 1450 rpm

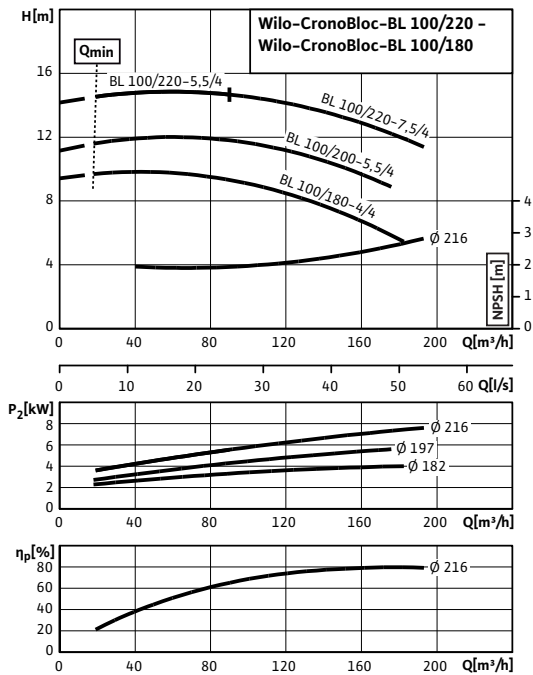

Wilo-CronoBloc-BL 100/250-11/4 - 100/270-15/4

Speed 1450 rpm

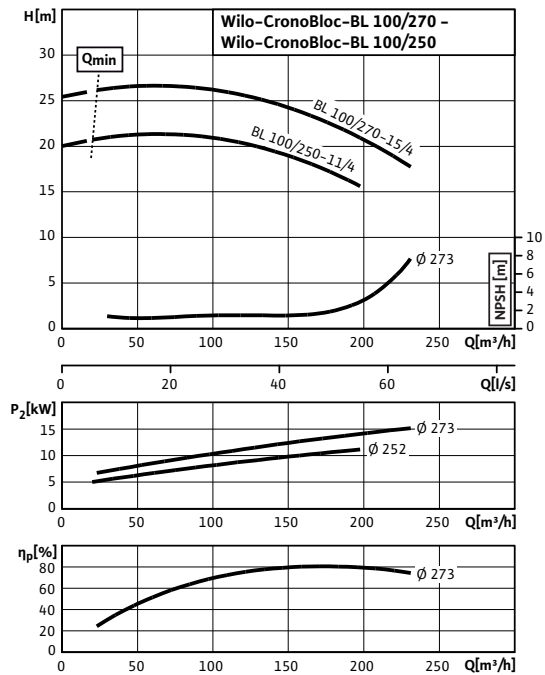

Monobloc pumps

Single pumps (heating, air-conditioning, cooling and industry)



Pump curves Wilo-CronoBloc-BL

Wilo-CronoBloc-BL 100/300-18,5/4 - 100/340-30/4

Speed 1450 rpm

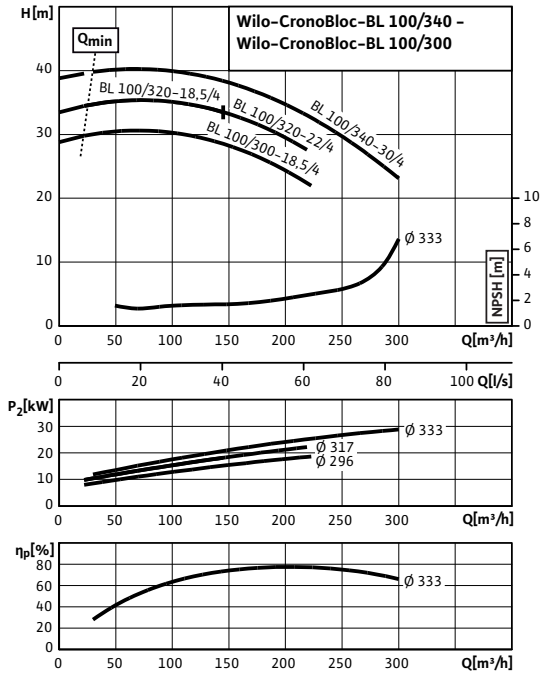

Wilo-CronoBloc-BL 125/190-5,5/4 - 125/220-11/4

Speed 1450 rpm

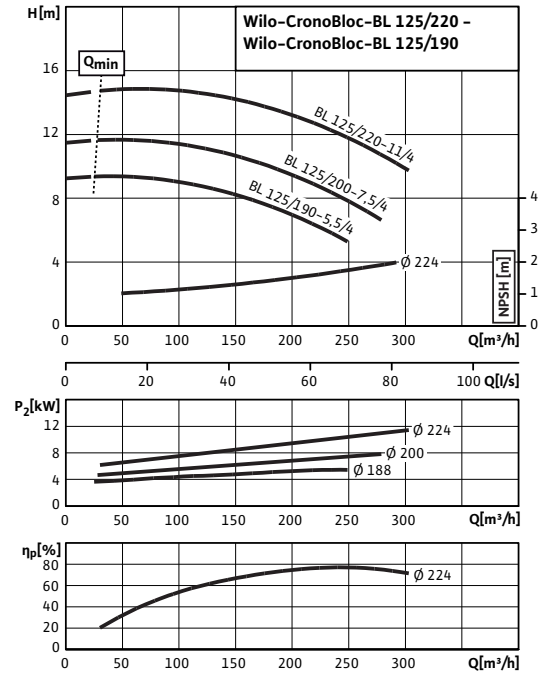

Wilo-CronoBloc-BL 125/250-15/4 - 125/270-22/4

Speed 1450 rpm

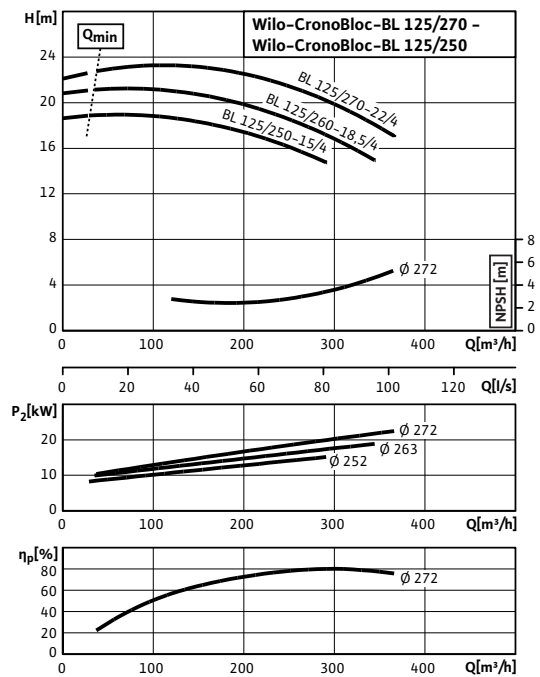

Monobloc pumps

Single pumps (heating, air-conditioning, cooling and industry)

Terminal diagram, motor data Wilo-CronoBloc-BL

Terminal diagrams

Star switching Y

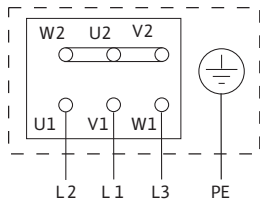

Delta switching Δ

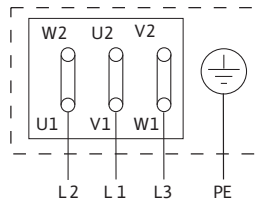

Motor protection switch required onsite. Check the direction of rotation.

To change the direction of rotation, swap any two phases.

$P_2 \leq 3 \text{ kW}$ 3~400 V Y
3~230 V Δ

$P_2 \geq 4 \text{ kW}$ 3~690 V Y
3~400 V Δ

After removing the bridges, Y-Δ starting is possible.

Motor data (1450 rpm)

	Nominal current (approx.)	Power factor	Efficiency
	I_N 3~400 V	$\cos \varphi$	η_M
	[A]	—	—
0.37 kW	1.06	0.78	0.65
0.55 kW	1.44	0.82	0.67
0.75 kW	1.91	0.81	0.72
1.1 kW	2.55	0.81	0.77
1.5 kW	3.40	0.81	0.79
2.2 kW	4.70	0.82	0.82
3 kW	6.40	0.82	0.83
4 kW	8.20	0.83	0.85
5.5 kW	11.40	0.81	0.86
7.5 kW	15.20	0.82	0.87
11 kW	21.50	0.84	0.89
15 kW	28.50	0.84	0.90
18.5 kW	35.50	0.83	0.91
22 kW	41.50	0.84	0.91

Observe motor name plate data

Motor data (2900 rpm)

	Nominal current (approx.)	Power factor	Efficiency
	I_N 3~400 V	$\cos \varphi$	η_M
	[A]	—	—
1.5 kW	3.25	0.85	0.79
2.2 kW	4.55	0.85	0.82
3 kW	6.10	0.85	0.84
4 kW	7.80	0.86	0.86
5.5 kW	10.40	0.89	0.86
7.5 kW	13.80	0.89	0.88
11 kW	20.00	0.88	0.90
15 kW	26.50	0.90	0.90
18.5 kW	32.00	0.91	0.91
22 kW	39.50	0.88	0.92
30 kW	53.00	0.89	0.92
37 kW	65.00	0.89	0.93

Observe motor name plate data

Monobloc pumps

Single pumps (heating, air-conditioning, cooling and industry)



Dimensions, weights Wilo-CronoBloc-BL

Dimension drawing A

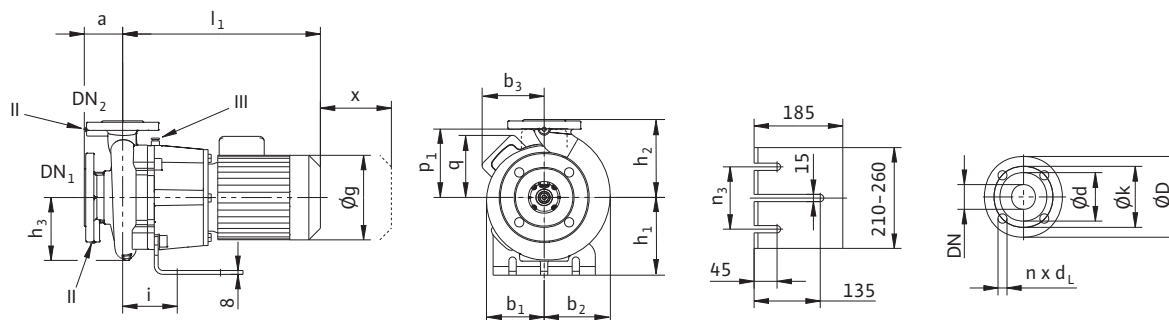

II Pressure measuring connection $R^{1/8}$; III Ventilation $R^{1/8}$

Dimensions, weights (1450 rpm)

Wilo-CronoBloc-BL ...	Nominal diameter		Dimensions														Weight approx.
	DN ₁	DN ₂	A	b ₁	b ₂	b ₃	øg	h ₁	h ₂	h ₃	i	l _{1max}	n ₃	p ₁	q	x	M
	[mm]																
32/150-0.37/4	50	32	80	113	129	118	145	160	160	122	110	398	130	-	118	95	41
32/160-0.55/4	50	32	80	113	129	124	188	160	160	122	110	423	130	-	124	95	43
32/170-0.75/4	50	32	80	113	129	124	188	160	160	122	110	423	130	-	124	95	45
32/210-1.1/4	50	32	80	145	149	-	193	180	180	145	117	460	180	151	-	100	50
32/220-1.5/4	50	32	80	145	149	-	193	180	180	145	117	460	180	151	-	100	54
40/150-0.55/4	65	40	80	120	135	124	188	160	160	132	114	423	130	-	124	100	45
40/160-0.75/4	65	40	80	120	135	124	188	160	160	132	114	423	130	-	124	100	47
40/170-1.1/4	65	40	80	120	135	145	193	160	160	132	114	403	130	-	145	100	51
40/210-1.5/4	65	40	100	145	151	-	193	180	180	145	124	467	180	151	-	100	56
40/220-2.2/4	65	40	100	145	151	-	217	180	180	145	124	511	180	160	-	100	65
40/260-3/4	65	40	100	174	178	-	217	200	225	160	123	510	180	160	-	110	74
40/270-3/4	50	40	100	174	178	-	217	200	225	160	123	510	180	160	-	110	74
40/270-4/4	65	40	100	174	178	-	232	200	225	160	123	588	180	178	-	110	81
50/160-1.1/4	65	50	100	127	147	145	193	160	180	152	122	471	130	-	145	120	52
50/170-1.1/4	65	50	100	127	147	145	193	160	180	152	122	471	130	-	145	120	52
50/170-1.5/4	65	50	100	127	147	149	193	160	180	152	122	471	130	-	149	120	56
50/200-2.2/4	65	50	100	153	172	-	217	180	200	159	124	511	180	160	-	110	68
50/220-2.2/4	65	50	100	153	172	-	217	180	200	159	124	511	180	160	-	110	68
50/220-3/4	65	50	100	153	172	-	217	180	200	159	124	511	180	160	-	110	71
50/250-3/4	65	50	100	174	186	-	217	200	225	179	131	518	180	160	-	110	78
50/250-4/4	65	50	100	174	186	-	232	200	225	179	131	596	180	178	-	110	84
65/150-1.1/4	80	65	100	136	162	145	193	160	200	155	130	479	130	-	145	120	60
65/160-1.5/4	80	65	100	136	162	149	193	160	200	155	130	479	130	-	149	120	64
65/170-2.2/4	80	65	100	136	162	156	217	160	200	155	130	523	130	-	156	120	75
65/210-3/4	80	65	100	156	181	-	217	200	225	170	139	525	180	160	-	120	76
65/220-4/4	80	65	100	156	181	-	232	200	225	170	139	603	180	178	-	120	76
80/150-1.5/4	100	80	125	160	196	149	193	180	225	178	137	486	130	-	149	135	74

Monobloc pumps

Single pumps (heating, air-conditioning, cooling and industry)

Dimensions, weights Wilo-CronoBloc-BL

Dimensions, weights (1450 rpm)

Wilo-CronoBloc-BL ...	Nominal diameter		Dimensions														Weight approx.
	DN ₁	DN ₂	A	b ₁	b ₂	b ₃	∅ g	h ₁	h ₂	h ₃	i	l _{1max}	n ₃	p ₁	q	x	M
	[mm]																[kg]
80/160-2.2/4	100	80	125	160	196	156	217	180	225	178	137	530	130	-	156	135	86
80/170-3/4	100	80	125	160	196	156	217	180	225	178	137	530	130	-	156	135	88
80/200-3/4	100	80	125	170	197	-	217	200	250	178	143	530	182	178	-	120	86
80/200-4/4	100	80	125	170	197	-	232	200	250	178	143	608	180	178	-	120	92
100/180-4/4	125	100	125	176	211	0	232	200	280	196	156	621	180	178	0	120	96

Dimensions, weights (2900 rpm)

Wilo-CronoBloc-BL ...	Nominal diameter		Dimensions														Weight approx.
	DN ₁	DN ₂	A	b ₁	b ₂	b ₃	∅ g	h ₁	h ₂	h ₃	i	l _{1max}	n ₃	p ₁	q	x	M
	[mm]																[kg]
32/140-2.2/2	50	32	80	113	129	149	193	160	160	122	110	463	130	-	149	95	52
32/150-3/2	50	32	80	113	129	156	217	160	160	122	110	506	130	-	156	95	61
32/160-4/2	50	32	80	113	129	168	232	160	160	122	110	584	130	-	168	95	68
40/110-1.5/2	65	40	80	101	119	145	193	160	140	111	114	461	130	-	145	100	42
40/120-2.2/2	65	40	80	101	119	149	193	160	140	111	114	461	130	-	149	100	46
40/130-3/2	65	40	80	101	119	156	217	160	140	111	114	505	130	-	156	100	57
40/140-3/2	65	40	80	101	119	156	217	160	140	111	114	505	130	-	156	100	57
40/140-4/2	65	40	80	101	119	168	232	160	140	111	114	583	130	-	168	100	64
50/110-3/2	65	50	100	111	133	156	217	160	160	124	121	512	130	-	156	110	61
50/120-3/2	65	50	100	111	133	156	217	160	160	124	121	512	130	-	156	110	61
50/120-4/2	65	50	100	111	133	168	232	160	160	124	121	590	130	-	168	110	68
65/120-4/2	80	65	100	123	151	168	232	160	180	155	127	595	130	-	168	120	74

Monobloc pumps

Single pumps (heating, air-conditioning, cooling and industry)



Dimensions, weights Wilo-CronoBloc-BL

Dimension drawing B

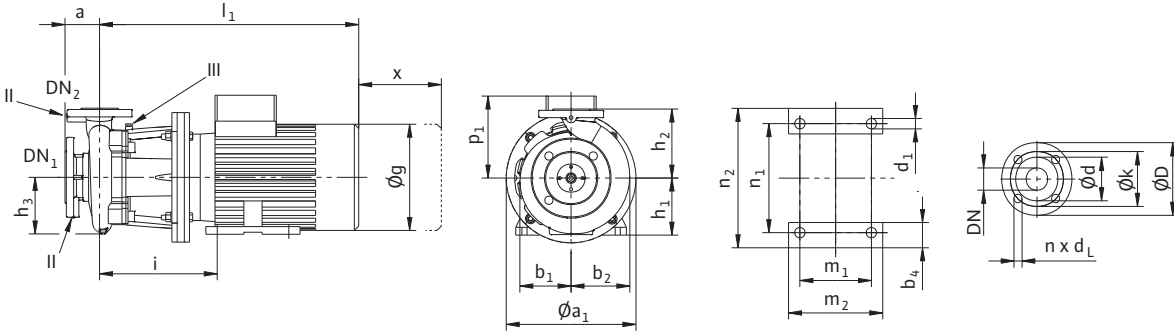

II Pressure measuring connection R¹/₈; III Ventilation R¹/₈

Dimensions, weights (1450 rpm)

Wilo-CronoBloc-BL ...	Nominal diameter		Dimensions																		Weight approx.	
	DN ₁	DN ₂	A	Ø a ₁	b ₁	b ₂	b ₄	d ₁	Ø g	h ₁	h ₂	h ₃	i	l _{1max}	m ₁	m ₂	n ₁	n ₂	p ₁	x	M	
	[mm]																					
50/270-5.5/4	65	50	100	300	174	186	53	12	279	132	225	179	306	652	140	180	216	256	188	110	99	
65/270-5.5/4	80	65	100	300	184	203	53	12	279	132	250	196	304	650	140	180	216	256	188	115	106	
80/220-5.5/4	100	80	125	300	170	197	53	12	279	132	250	178	318	664	140	180	216	256	188	120	106	
80/250-5.5/4	100	80	125	300	192	218	53	12	279	132	280	199	309	655	140	180	216	256	188	120	113	
80/250-7.5/4	100	80	125	300	192	218	53	12	323	132	280	199	309	696	178	218	216	256	188	120	121	
80/270-11/4	100	80	125	350	192	218	60	15	323	160	280	199	369	778	210	256	254	300	250	120	157	
100/200-5.5/4	125	100	125	300	176	211	53	12	279	132	280	196	331	677	140	180	216	256	188	120	111	
100/220-5.5/4	125	100	125	300	176	211	53	12	279	132	280	196	331	677	140	180	216	256	188	120	111	
100/220-7.5/4	125	100	125	300	176	211	53	12	323	132	280	196	331	718	178	218	216	256	188	120	119	
100/250-11/4	125	100	140	350	200	232	60	15	323	160	280	222	383	792	210	256	254	300	250	130	173	
100/270-15/4	125	100	140	350	200	232	60	15	370	160	280	222	383	835	254	300	254	300	250	130	185	
100/300-18.5/4	125	100	140	350	265	297	70	15	370	180	315	248	417	898	241	287	279	339	294	140	250	
100/320-18.5/4	125	100	140	350	265	297	70	15	370	180	315	248	417	898	241	287	279	339	294	140	250	
100/320-22/4	125	100	140	350	265	297	70	15	370	180	315	248	417	926	279	325	279	339	294	140	270	
100/340-30/4	125	100	140	400	265	297	83	19	415	200	315	248	429	986	305	355	318	388	306	140	306	
125/190-5.5/4	150	125	140	300	235	279	53	12	279	132	355	256	343	689	140	180	216	256	188	140	128	
125/200-7.5/4	150	125	140	300	235	279	53	12	323	132	355	256	343	730	178	218	216	256	188	140	136	
125/220-11/4	150	125	140	350	235	279	60	15	323	160	355	256	404	813	210	256	254	300	250	140	170	
125/250-15/4	150	125	140	350	235	279	60	15	370	160	355	256	419	871	254	300	254	300	250	140	231	
125/260-18.5/4	150	125	140	350	235	279	70	15	370	180	355	256	432	913	241	287	279	339	294	140	259	
125/270-22/4	150	125	140	350	235	279	70	15	370	180	355	256	432	941	279	325	279	339	294	140	269	

Monobloc pumps

Single pumps (heating, air-conditioning, cooling and industry)

Dimensions, weights Wilo-CronoBloc-BL

Dimensions, weights (2900 rpm)

Wilo-CronoBloc-BL ...	Nominal diameter		Dimensions																		Weight approx.
	DN 1	DN 2	A	Ø a1	b ₁	b ₂	b ₄	d ₁	Ø g	h ₁	h ₂	h ₃	i	l _{1max}	m ₁	m ₂	n ₁	n ₂	p ₁	x	M
	[mm]																				[kg]
32/170-5.5/2	50	32	80	325	113	129	53	12	279	132	160	122	284	630	140	180	216	256	188	95	78
32/210-7.5/2	50	32	80	325	145	149	53	12	279	132	180	145	292	638	140	180	216	256	188	100	92
32/220-11/2	50	32	80	350	145	149	60	15	323	160	180	145	352	761	210	256	254	300	250	100	123
40/160-5.5/2	65	40	80	325	120	135	53	12	279	132	160	132	285	631	140	180	216	256	188	100	83
40/170-5.5/2	65	40	80	325	120	135	53	12	279	132	160	132	285	631	140	180	216	256	188	100	84
40/170-7.5/2	65	40	80	325	120	135	53	12	279	132	160	132	285	631	140	180	216	256	188	100	93
40/180-7.5/2	65	40	100	325	145	151	53	12	279	132	180	145	299	645	140	180	216	256	188	100	94
40/210-11/2	65	40	100	350	145	151	60	15	323	160	180	145	359	768	210	256	254	300	250	100	125
40/220-11/2	65	40	100	350	145	151	60	15	323	160	180	145	359	768	210	256	254	300	250	100	125
40/220-15/2	65	40	100	350	145	151	60	15	323	160	180	145	359	768	210	256	254	300	250	100	136
40/250-22/2	65	40	100	350	174	178	70	15	415	180	225	160	373	854	241	287	279	339	294	110	191
40/270-22/2	50	40	100	350	174	178	70	15	370	180	225	160	373	854	241	287	279	339	294	110	191
40/270-30/2	65	40	100	400	174	178	83	19	415	200	225	160	402	959	305	355	318	388	306	110	239
50/130-5.5/2	65	50	100	325	111	133	53	12	279	132	160	124	296	642	140	180	216	256	188	110	77
50/140-5.5/2	65	50	100	300	111	133	53	12	279	132	160	124	296	642	140	180	216	256	188	110	77
50/140-7.5/2	65	50	100	325	111	133	53	12	279	132	160	124	296	642	140	180	216	256	188	110	85
50/150-5.5/2	65	50	100	325	127	147	53	12	279	132	180	152	293	639	140	180	216	256	188	120	85
50/150-7.5/2	65	50	100	325	127	147	53	12	279	132	180	152	293	639	140	180	216	256	188	120	95
50/170-11/2	65	50	100	350	127	147	60	15	323	160	180	152	362	771	210	256	254	300	250	120	117
50/200-11/2	65	50	100	350	153	172	60	15	323	160	200	159	359	768	210	256	254	300	250	110	129
50/200-15/2	65	50	100	350	153	172	60	15	323	160	200	159	359	768	210	256	254	300	250	110	140
50/210-15/2	65	50	100	350	153	172	60	15	323	160	200	159	359	768	210	256	254	300	250	110	140
50/210-18.5/2	65	50	100	350	153	172	60	15	323	160	200	159	359	811	254	300	254	300	250	110	153
50/220-18.5/2	65	50	100	350	153	172	60	15	370	160	200	159	359	811	254	300	254	300	250	110	153
50/220-22/2	65	50	100	350	153	172	70	15	415	180	200	159	372	853	241	287	279	339	294	110	175
50/240-30/2	65	50	100	400	174	186	83	19	415	200	225	179	410	967	305	355	318	388	306	110	244
50/260-30/2	65	50	100	400	174	186	83	19	415	200	225	179	410	967	305	355	318	388	306	110	244
50/260-37/2	65	50	100	400	174	186	83	19	415	200	225	179	410	967	305	355	318	388	306	110	267
65/130-5.5/2	80	65	100	325	123	151	53	12	279	132	180	155	301	647	140	180	216	256	188	120	83
65/140-7.5/2	80	65	100	325	123	151	53	12	279	132	180	155	301	647	140	180	216	256	188	120	91
65/160-11/2	80	65	100	350	136	162	60	15	323	160	200	155	370	779	210	256	254	300	250	120	125
65/170-11/2	80	65	100	350	136	162	60	15	323	160	200	155	370	822	210	256	254	300	250	120	125
65/170-15/2	80	65	100	350	136	162	60	15	323	160	200	155	370	779	210	256	254	300	250	120	138
65/190-15/2	80	65	100	350	156	181	60	15	323	160	225	170	374	826	210	256	254	300	250	120	144
65/190-18.5/2	80	65	100	350	156	181	60	15	323	160	225	170	374	826	254	300	254	300	250	120	157
65/210-18.5/2	80	65	100	350	156	181	60	15	370	160	225	170	374	826	254	300	254	300	250	120	157
65/210-22/2	80	65	100	350	156	181	70	15	415	180	225	170	387	868	241	287	279	339	294	120	180
65/220-30/2	80	65	100	400	156	181	83	19	415	200	225	170	399	956	305	355	318	388	306	120	234
80/145-11/2	100	80	125	350	160	196	60	15	323	160	225	178	377	786	210	256	254	300	250	135	136
80/150-15/2	100	80	125	350	160	196	60	15	323	160	225	178	377	786	210	256	254	300	250	135	149
80/160-15/2	100	80	125	350	160	196	60	15	323	160	225	178	377	786	210	256	254	300	250	135	149
80/160-18.5/2	100	80	125	350	160	196	60	15	323	160	225	178	377	829	254	300	254	300	250	135	166
80/165-22/2	100	80	125	350	160	196	70	15	415	180	225	178	390	871	241	287	279	339	294	135	181

Monobloc pumps

Single pumps (heating, air-conditioning, cooling and industry)



Dimensions, weights Wilo-CronoBloc-BL

Dimensions, weights (2900 rpm)

Wilo-CronoBloc-BL ...	Nominal diameter		Dimensions																		Weight approx.
	DN ₁	DN ₂	A	∅ a ₁	b ₁	b ₂	b ₄	d ₁	∅ g	h ₁	h ₂	h ₃	i	l _{1max}	m ₁	m ₂	n ₁	n ₂	p ₁	x	M
	[mm]																				[kg]
80/170-30/2	100	80	125	400	160	196	83	19	415	200	225	178	402	959	305	355	318	388	306	135	236
80/200-30/2	100	80	125	400	170	197	83	19	415	200	250	178	403	960	305	355	318	388	306	120	244
80/210-30/2	100	80	125	400	170	197	83	19	415	200	250	178	403	960	305	355	318	388	306	120	244
80/210-37/2	100	80	125	400	170	197	83	19	415	200	250	178	403	960	305	355	318	388	306	120	267

Flange dimensions (suction side)

Wilo-CronoBloc-BL ...	Nominal diameter	Pump flange dimensions			
	DN ₁	∅ D ₁	∅ d ₁	∅ k ₁	n x d _{L1}
	[mm]				[pcs. x mm]
32...	50	165	99	125	4 x 19
40...	65	185	118	145	4 x 19
50...	65	185	118	145	4 x 19
65...	80	200	132	160	8 x 19
80...	100	220	156	180	8 x 19
100...	125	250	184	210	8 x 19
125...	150	285	211	240	8 x 23

Pump flange dimensions - according to EN 1092-2 PN 16; n = number of drilled holes

Flange dimensions (pressure side)

Wilo-CronoBloc-BL ...	Nominal diameter	Pump flange dimensions			
	DN ₂	∅ D ₂	∅ d ₂	∅ k ₂	n x d _{L2}
	[mm]				[pcs. x mm]
32...	32	140	76	100	4 x 19
40...	40	150	84	110	4 x 19
50...	50	165	99	125	4 x 19
65...	65	185	118	145	4 x 19
80...	80	200	132	160	8 x 19
100...	100	220	156	180	8 x 19
125...	125	250	184	210	8 x 19

Pump flange dimensions - according to EN 1092-2 PN 16; n = number of drilled holes

Norm pumps

Single pumps (heating, air-conditioning, cooling and industry)

Series overview

Series: Wilo-CronoNorm-NL



> Design

Baseplate pump with axial suction, in accordance with EN 733 (previously DIN 24255) and ISO 5199

> Application

- Pumping clean or slightly contaminated water (max. 20 ppm) without solid matter for circulation, transfer and pressure boosting purposes.
- Pumping heating water in accordance with VDI 2035, water-glycol mixtures, cooling/cold water and industrial water
- Applications in municipal water supply, irrigation, building services, general industry, power stations, etc.

Series: Wilo-VeroNorm NPG



> Design

Single-stage low-pressure centrifugal pump mounted on the baseplate

> Application

- Pumping heating water in accordance with VDI 2035 water-glycol mixtures, cooling/cold water and secondary hot water
- Applications in municipal water supply, irrigation, building services, general industry, power stations, etc.

Norm pumps

Single pumps (heating, air-conditioning, cooling and industry)



Series overview

Series: Wilo-CronoNorm-NL

> Special features/product benefits

- Burgmann mechanical seal with conical seal chamber
- Branded shaft protection
- SPM connections for vibration and temperature sensors
- Shaft deflection in accordance with the DIN ISO 5199
- Greased for life 2Z oversized ball bearings

> More information

- | | Page |
|-----------------------------|------|
| • Planning guide | 6 |
| • Technical data | 42 |
| • Series description | 44 |
| • Pump curves..... | 50 |
| • Dimensions, weights | 67 |

Series: Wilo-VeroNorm NPG

> Special features/product benefits

- Made for temperatures up to 140°C
- Back Pull Out design
- Extension of the DIN EN 733 range

> More information

- | | Page |
|-----------------------------|------|
| • Planning guide | 6 |
| • Technical data | 90 |
| • Series description | 84 |
| • Pump curves..... | 93 |
| • Dimensions, weights | 99 |

Norm pumps

Single pumps (heating, air-conditioning, cooling and industry)

Series description Wilo-CronoNorm-NL



Design

Baseplate pump with axial suction, in accordance with EN 733 (previously DIN 24255) and ISO 5199

Type key

Example	NL 40/200B-11/2
NL	Standard pump with axial suction
40	DN for pressure flange
200b	Nominal width of impeller
11	Nominal motor power in kW
2	2-pole motor

Application

- Pumping clean or slightly contaminated water (max. 20 ppm) without solid matter for circulation, transfer and pressure boosting purposes.
- Pumping heating water in accordance with VDI 2035, water/glycol mixtures, cooling/cold water and industrial water
- Applications in municipal water supply, irrigation, building services, general industry, power stations, etc.

Special features/product advantages

- Burgmann mechanical seal with conical sealing chamber
- Brand shaft protection
- SPM connections for vibration and temperature sensors
- Shaft deflection according to DIN ISO 5199
- Permanently lubricated, generously dimensioned ball bearings (2Z version)

Description/design

- Single-stage low-pressure centrifugal pump as baseplate pump with axial suction piece with flanged bearing bracket and axis mounting for flexibly coupled drives.
- Spacer coupling (sleeve coupling) available as an option; they make it possible to leave the motor in position when removing the rotor unit
- Shaft deflection meets the requirements of ISO 5199

Materials

- Pump housing
 - Grey cast iron spiral with anti-rotation ribs.
 - With axially aligned suction piece and radial pressure ports and cast assembly feet.
 - Dimensions and hydraulics are in accordance with DIN EN 733
 - Flange PN 16 in accordance with DIN 2533 (DN 200 – PN 10/ DIN 2532)
- Standard mechanical shaft seal AQ1EGG for water up to 120°C
- Stuffing box for water up to 110°C

Scope of delivery

- Pump with free shaft end or
- Pump on baseplate with coupling and coupling protection, without motor or
- Completely mounted pump on baseplate with electric motor
- Housing: EN-GJL 250 – grey cast iron; impeller: EN-GJL 250 – grey cast iron or CC480K-GS – bronze; Mechanical seal or stuffing box; Standard coupling or spacer coupling
- Installation and operating instructions

Commissioning

- If pumps with 2900 rpm are installed inside residential buildings, appropriate noise-reducing measures must be taken.
- Pump curves and specific motor powers depend on the corresponding fluid. Pump curves and power vary considerably if fluids are pumped whose density and/or viscosity differ from water. **Please consider the table “Recommended limit values for dimensioning”!** The recommended limit values for dimensioning are calculated as follows:
Read Q_{optimum} (volume flow at which the pump reaches its best efficiency) from the individual pump curve; Take factors Q_{min} and Q_{max} from the table “Recommended limit values for dimensioning”.

$$Q_{\text{min dimensioning}} = Q_{\text{min}} \times Q_{\text{optimum}}$$
$$Q_{\text{max dimensioning}} = Q_{\text{max}} \times Q_{\text{optimum}}$$

Example: Construction size NL 32-125

$$Q_{\text{min}} = 0.3 \times 8 = 2.4 \text{ m}^3/\text{h}$$
$$Q_{\text{max}} = 1.2 \times 8 = 9.6 \text{ m}^3/\text{h}$$

- Load-sensitive pump output
All Wilo norm pumps are equipped with IEC standard motors. Wilo control devices are suitable for the automatic load-sensitive speed control of pumps which are driven by standard motors of any make.
- Main/standby mode

Accessories

Automatic speed control:
Wilo pump control system for the automatic, stageless power control of pumps. Further information can be found in the chapter “Switch-gears and control devices”.

Norm pumps

Single pumps (heating, air-conditioning, cooling and industry)



Series description Wilo-CronoNorm-NL

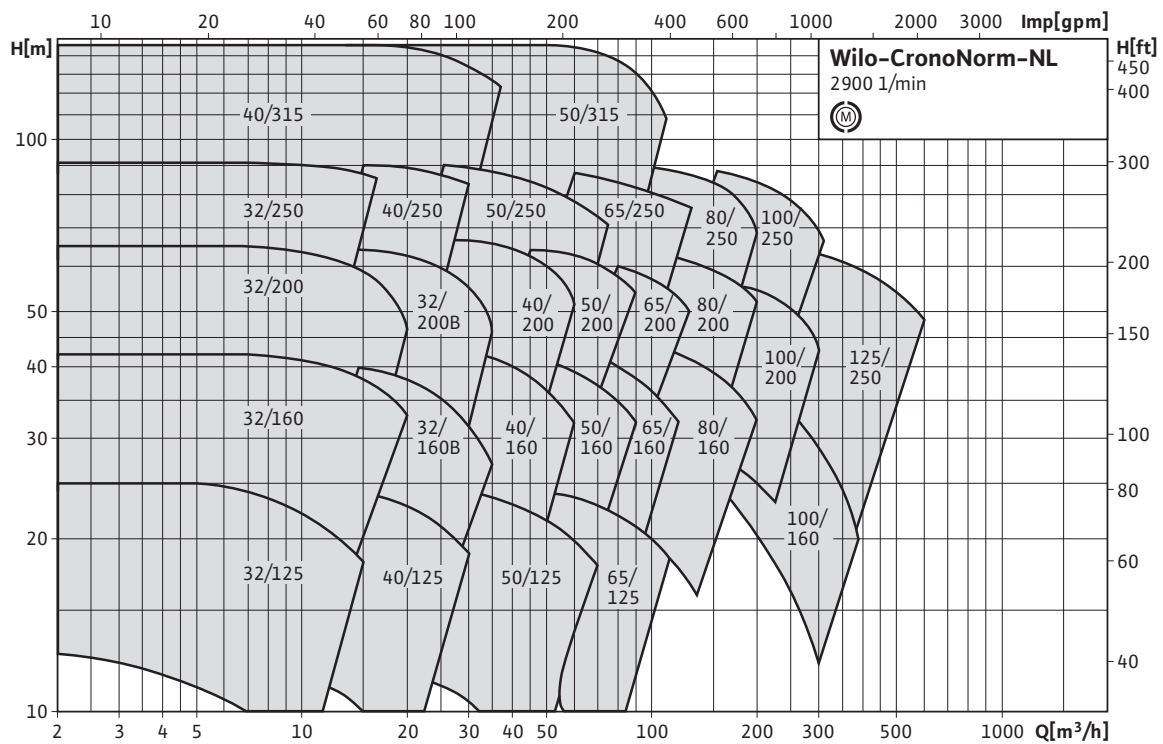
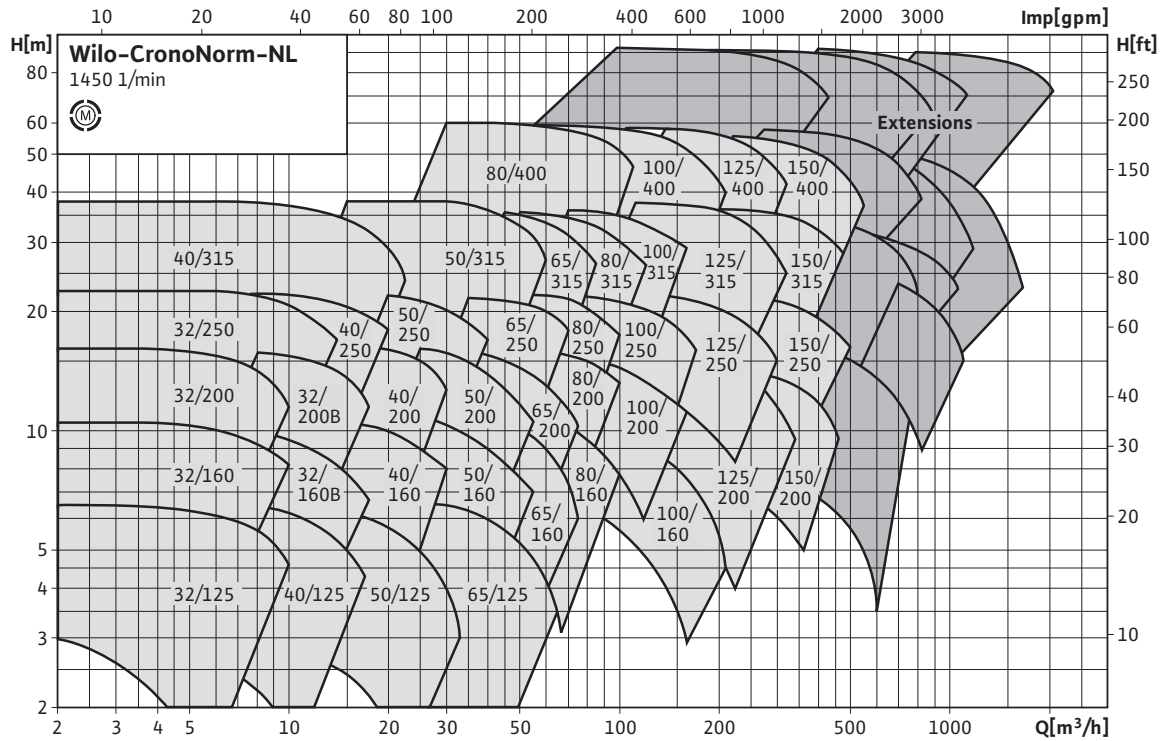

Norm pumps

Norm pumps

Single pumps (heating, air-conditioning, cooling and industry)

Series description Wilo-CronoNorm-NL

Motor data		
	Factor Q_{\min}	Factor Q_{\max}
	DN	$\varnothing D$
	–	[mm]
32/125	0.3	1.2
32/160	0.3	1.2
32/160B	0.3	1.2
32/200	0.3	1.2
32/200B	0.3	1.2
32/250	0.3	1.1
40/125	0.3	1.2
40/160	0.3	1.2
40/200	0.3	1.2
40/250	0.3	1.1
40/315	0.3	1.1
50/125	0.3	1.2
50/160	0.3	1.2
50/200	0.3	1.1
50/250	0.3	1.2
50/315	0.3	1.2
65/125	0.3	1.2
65/160	0.3	1.2
65/200	0.3	1.2
65/250	0.3	1.1
65/315	0.3	1.2
80/160	0.3	1.2
80/200	0.3	1.2
80/250	0.3	1.2
80/315	0.3	1.2
80/400	0.3	1.2
100/160	0.5	1.2
100/200	0.5	1.2
100/250	0.5	1.1
100/315	0.3	1.2
100/400	0.3	1.2
125/200	0.5	1.2
125/250	0.5	1.2
125/315	0.3	1.2
125/400	0.3	1.2
150/200	0.5	1.1
150/250	0.3	1.1
150/315	0.3	1.2
150/400	0.3	1.2

Norm pumps

Single pumps (heating, air-conditioning, cooling and industry)



Series description Wilo-CronoNorm-NL

Section drawing

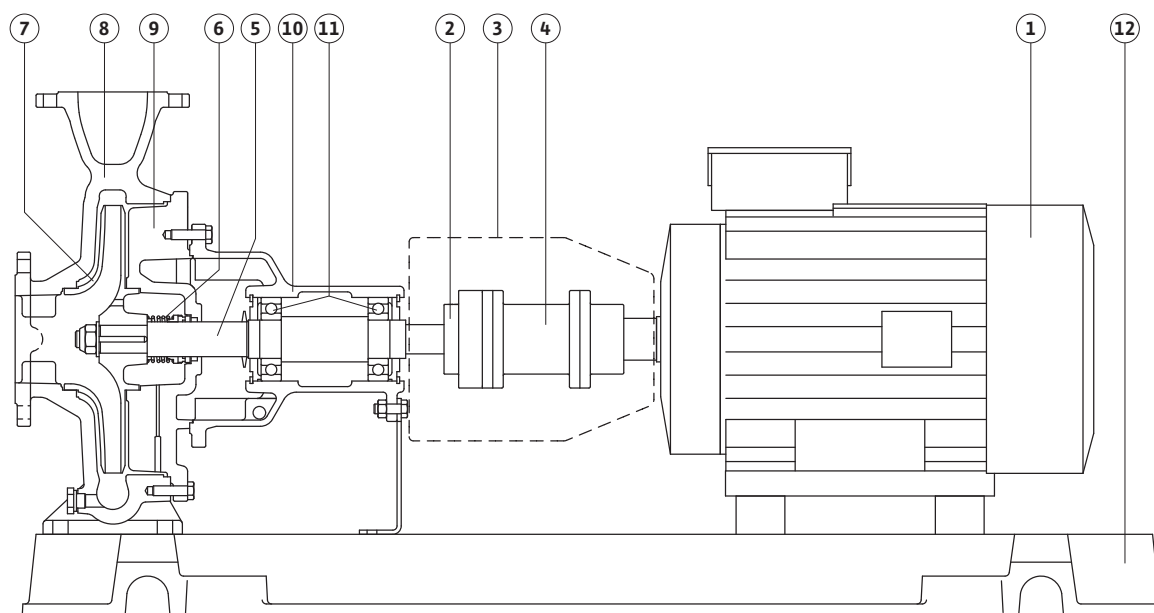

1	Motor	4	Spacer	7	Impeller	10	Bearing bracket
2	Coupling	5	Shaft	8	Pump housing	11	Roller bearing
3	Coupling protection	6	Mechanical seal	9	Housing cover	12	Baseplate

Norm pumps

Single pumps (heating, air-conditioning, cooling and industry)

Technical data Wilo-CronoNorm-NL	
Wilo- CronoNorm-NL	
Approved fluids (other fluids on request)	
Heating water (in accordance with VDI 2035)	•
Cooling and cold water	•
Water-glycol mixtures (for 20–40 vol.% glycol and fluid temperature ≤ 40 °C)	• (from 10 vol.% glycol: performance check required; up to 50% glycol: mechanical seal on request)
Permitted field of application	
Max. operating pressure at fluid temperature of +120°C [bar]	16 (type 32–125 to 80–315) 10 (type 80–400 to 150–400)
Maximum inlet pressure on suction side, DN 200 [bar]	10
Temperature range [°C]	-20 to +120 (fluids with mechanical seal)
Max. ambient temperature [°C]	40
Pipe connections	
Nominal connection diameters DN	on suction side: 50–200 (larger nominal diameters on request) on pressure side: 32–150 (larger nominal diameters on request)
Flanges (according to EN 1092–2)	PN 16 (up to nominal diameter DN 150); PN10 (nominal diameter DN 200)
Materials	
Pump housing	EN-GJL-250
Lantern	EN-GJL-250
Impeller (standard)	EN-GJL-250
Impeller (special version)	bronze CuSn8
Pump shaft	X30Cr13
Mechanical seal	AQ1EGG (carbon/silicon carbide/EPDM)
Other mechanical seals	on request (depending on the pumped liquid)
Non-cooled stuffing box	version at no additional charge
Electrical connection	
Speed range [rpm]	1450/2900
Speed range (special version at additional charge) [rpm]	950
Motor/electronics	
Factory standard IEC motor	•
West European brand production	special version at additional charge
Protection class	IP 55
Insulation class	F
PTC thermistor sensor	• tripping unit required
Motor protection required onsite	– (to be provided for onsite installation)

Norm pumps

Single pumps (heating, air-conditioning, cooling and industry)



Technical data Wilo-CronoNorm-NL

	Wilo- CronoNorm-NL
Energy efficiency class	EFF 2 (EFF1 at additional charge)
Speed control	Wilo control devices, external frequency converter (at additional charge)
Motor winding up to 3 kW	230 V Δ /400 V Y, 50 Hz
Motor winding from 4 kW	400 V Δ /690 V Y, 50 Hz
Other voltages/frequencies	special version at additional charge
Direct current	special version at additional charge
Explosion-protected versions	special version at additional charge

• = available, - = not available

Norm pumps

Single pumps (heating, air-conditioning, cooling and industry)

Pump curves Wilo-CronoNorm-NL (2-pole)

Wilo-CronoNorm-NL 32/125

Speed 2900 rpm

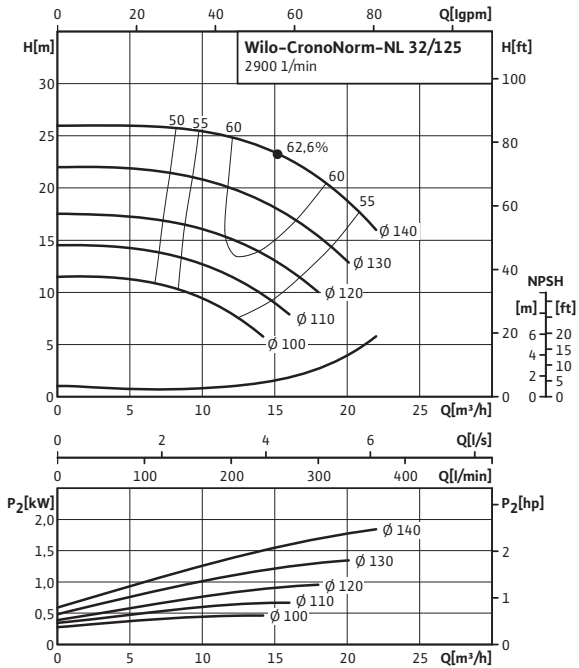

Wilo-CronoNorm-NL 32/160

Speed 2900 rpm

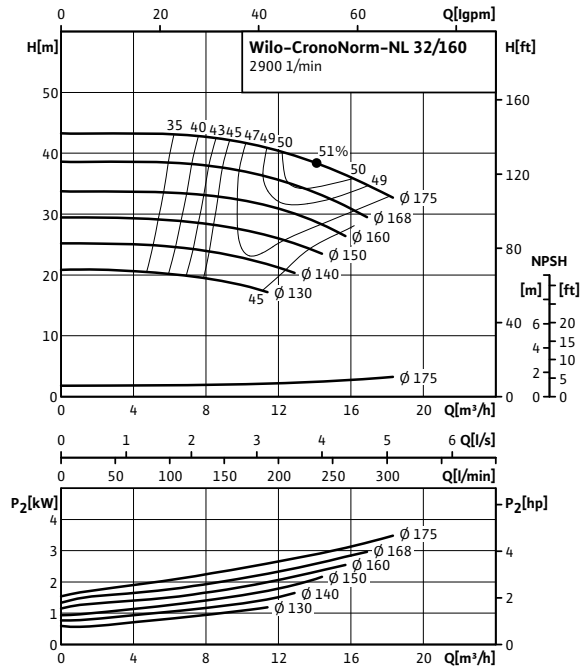

Wilo-CronoNorm-NL 32/160B

Speed 2900 rpm

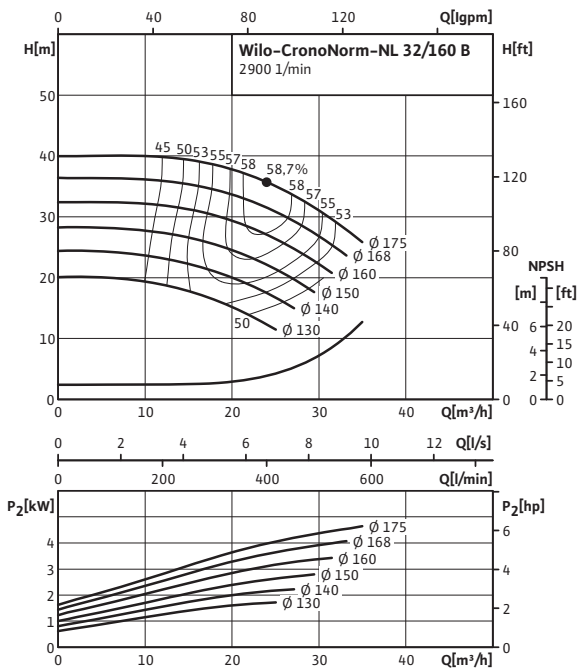

Wilo-CronoNorm-NL 32/200

Speed 2900 rpm

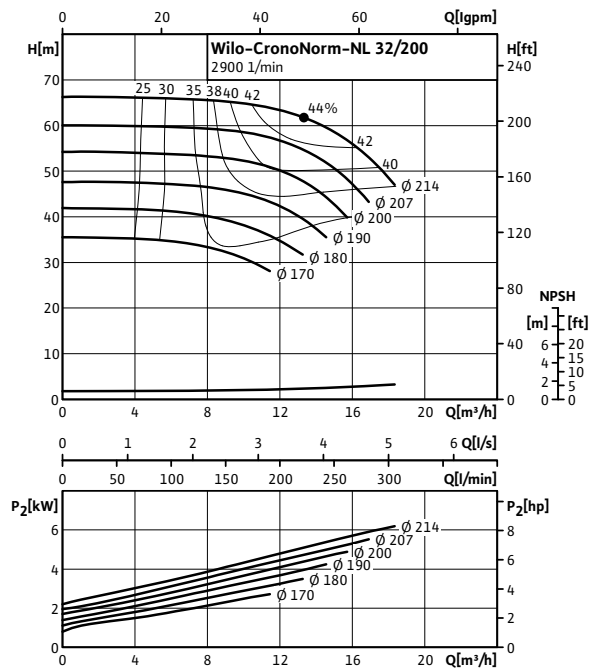

Norm pumps

Single pumps (heating, air-conditioning, cooling and industry)



Pump curves Wilo-CronoNorm-NL (2-pole)

Wilo-CronoNorm-NL 32/200B

Speed 2900 rpm

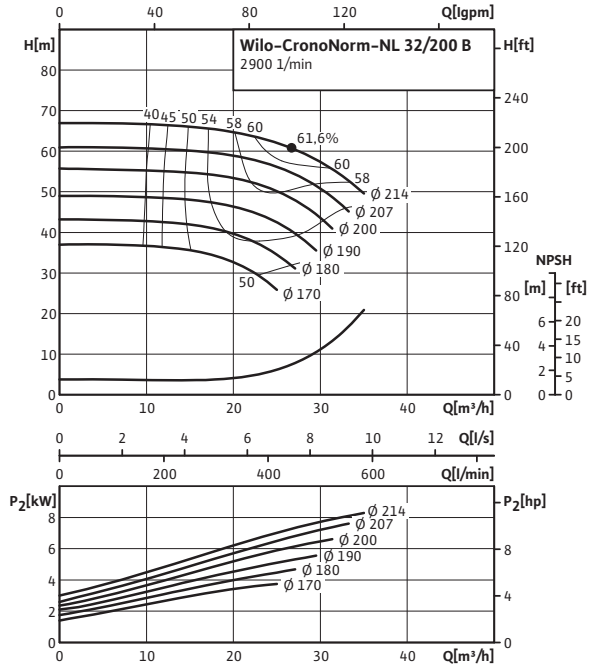

Wilo-CronoNorm-NL 32/250

Speed 2900 rpm

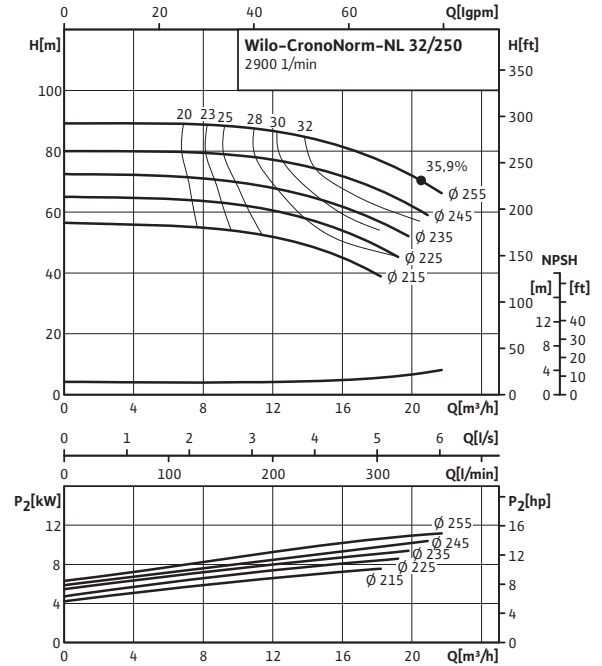

Wilo-CronoNorm-NL 40/125

Speed 2900 rpm

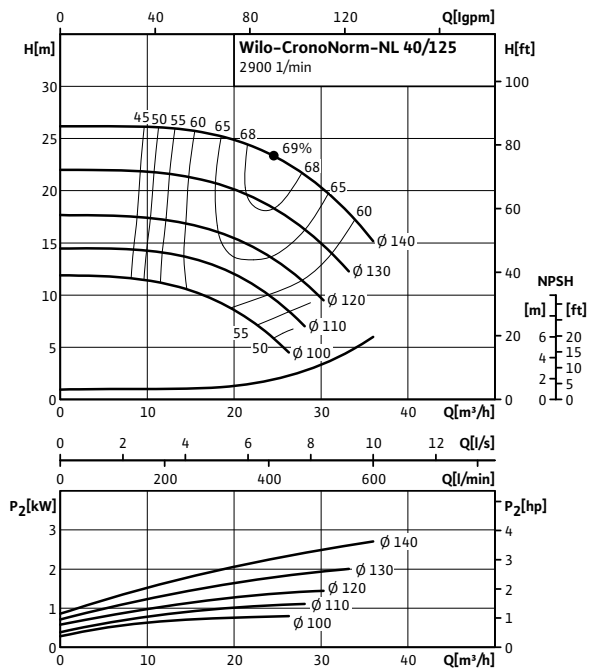

Wilo-CronoNorm-NL 40/160

Speed 2900 rpm

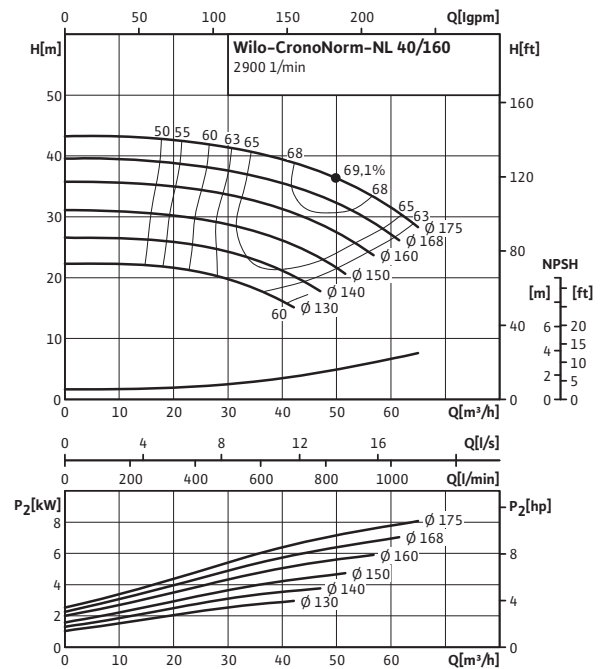

Norm pumps

Single pumps (heating, air-conditioning, cooling and industry)

Pump curves Wilo-CronoNorm-NL (2-pole)

Wilo-CronoNorm-NL 40/200

Speed 2900 rpm

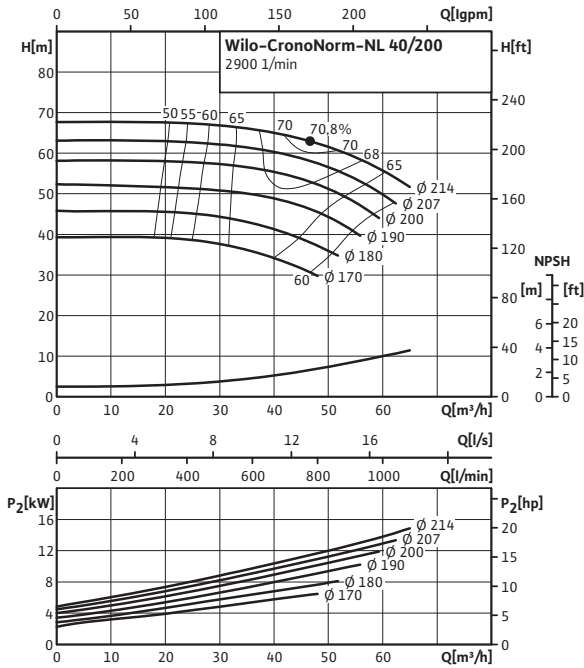

Wilo-CronoNorm-NL 40/250

Speed 2900 rpm

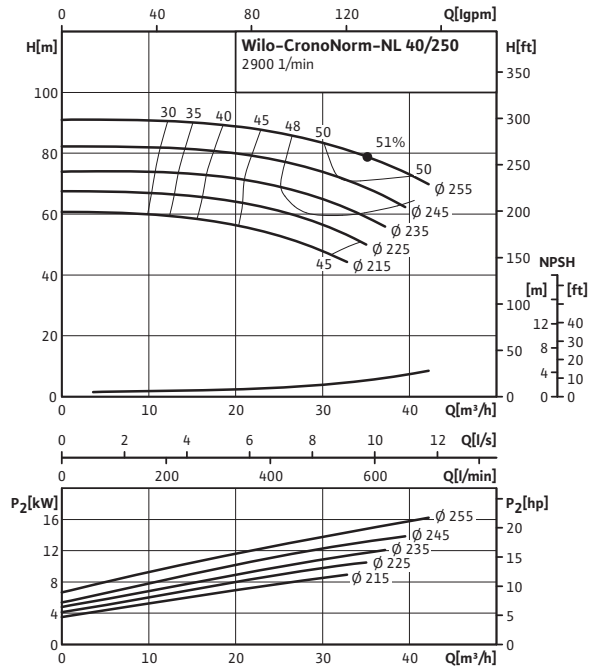

Wilo-CronoNorm-NL 40/315

Speed 2900 rpm

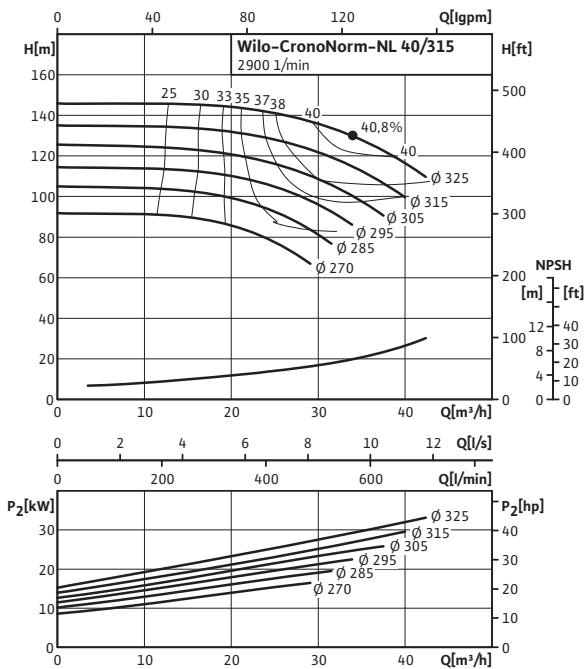

Wilo-CronoNorm-NL 50/125

Speed 2900 rpm

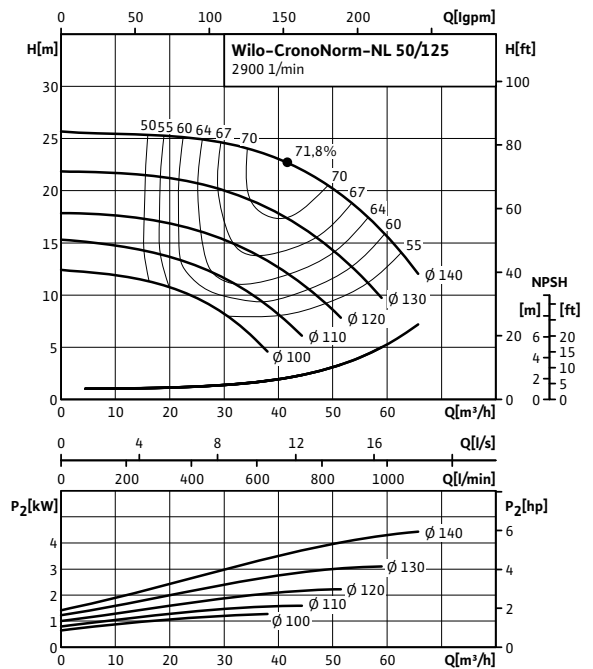

Norm pumps

Single pumps (heating, air-conditioning, cooling and industry)



Pump curves Wilo-CronoNorm-NL (2-pole)

Wilo-CronoNorm-NL 50/160

Speed 2900 rpm

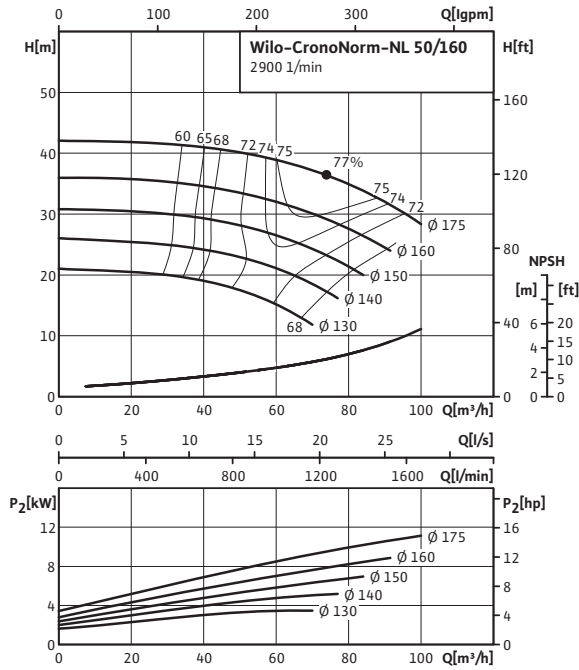

Wilo-CronoNorm-NL 50/200

Speed 2900 rpm

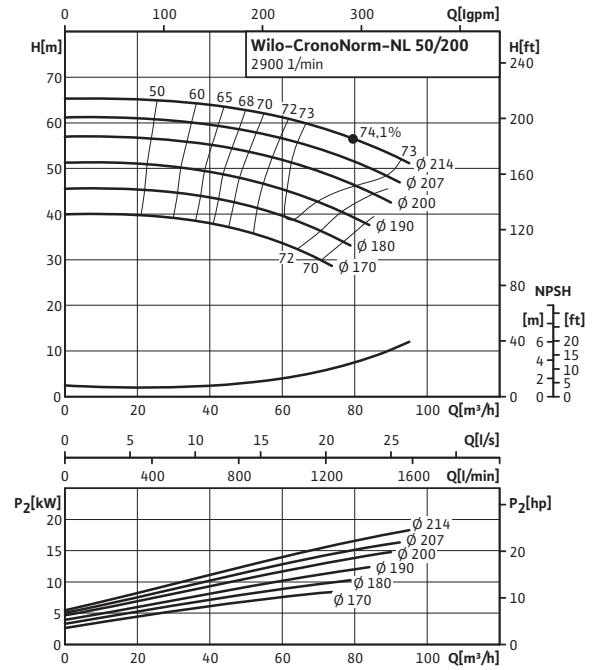

Wilo-CronoNorm-NL 50/250

Speed 2900 rpm

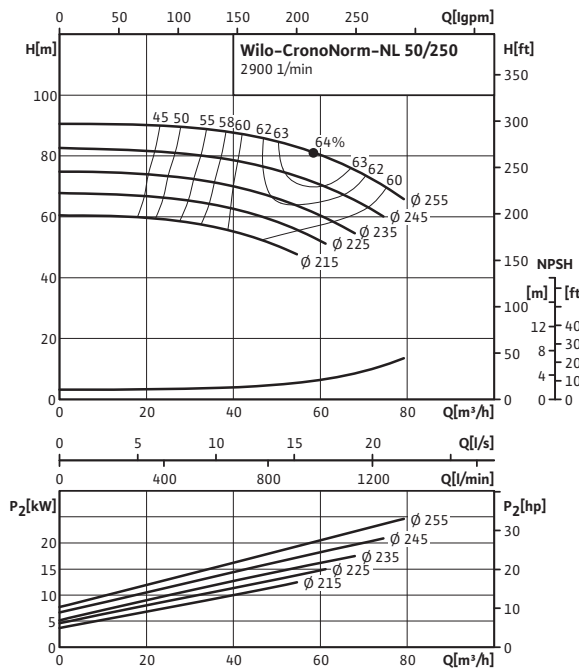

Wilo-CronoNorm-NL 50/315

Speed 2900 rpm

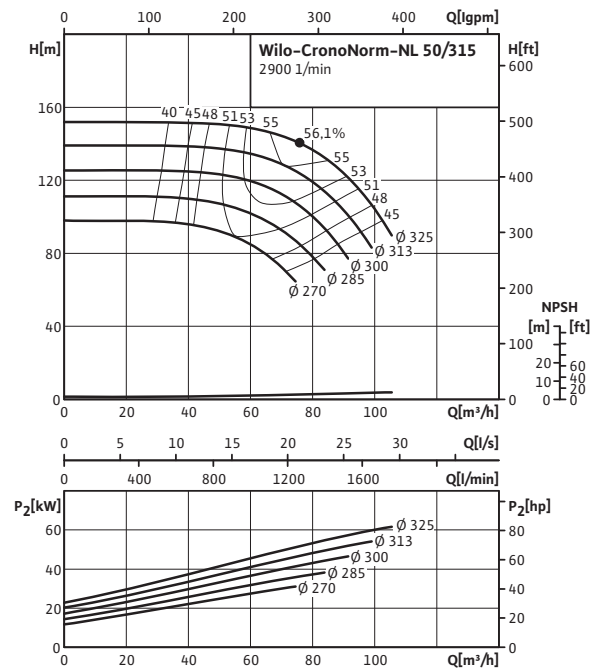

Norm pumps

Single pumps (heating, air-conditioning, cooling and industry)

Pump curves Wilo-CronoNorm-NL (2-pole)

Wilo-CronoNorm-NL 65/125

Speed 2900 rpm

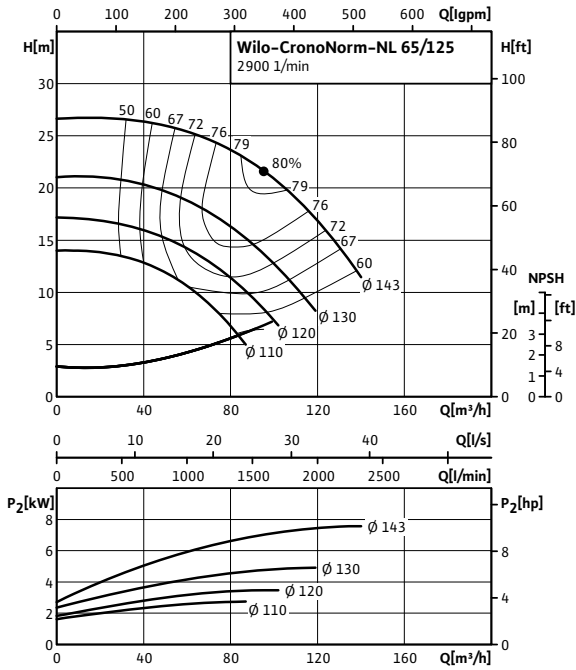

Wilo-CronoNorm-NL 65/160

Speed 2900 rpm

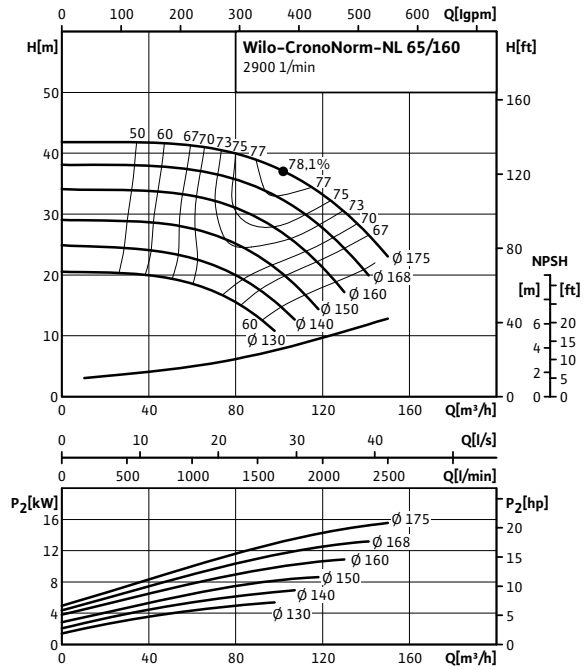

Wilo-CronoNorm-NL 65/200

Speed 2900 rpm

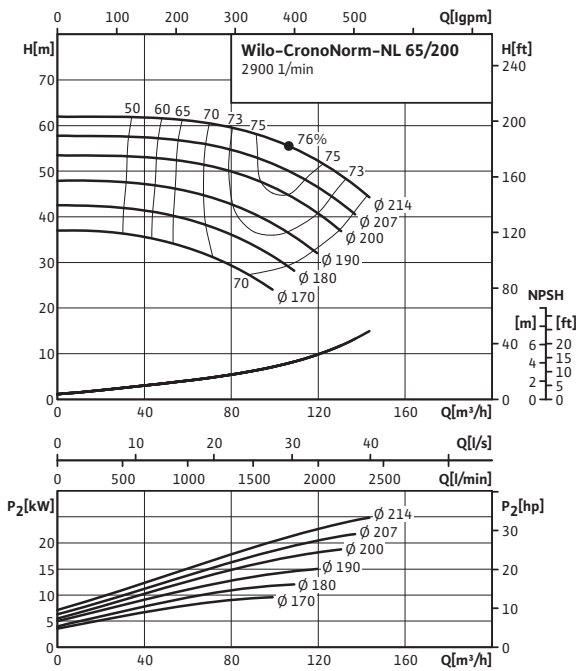

Wilo-CronoNorm-NL 65/250

Speed 2900 rpm

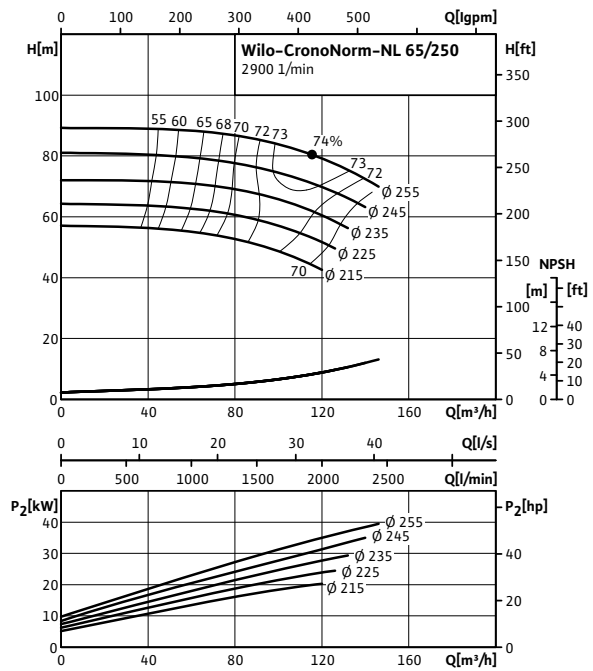

Norm pumps

Single pumps (heating, air-conditioning, cooling and industry)



Pump curves Wilo-CronoNorm-NL (2-pole)

Wilo-CronoNorm-NL 80/160

Speed 2900 rpm

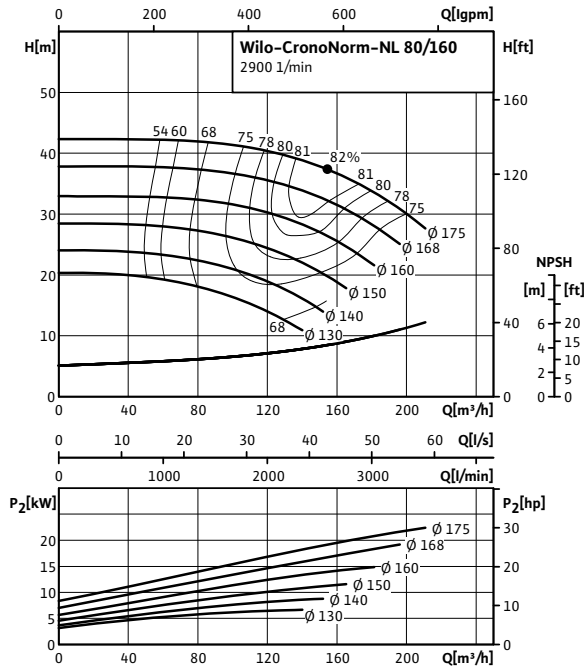

Wilo-CronoNorm-NL 80/200

Speed 2900 rpm

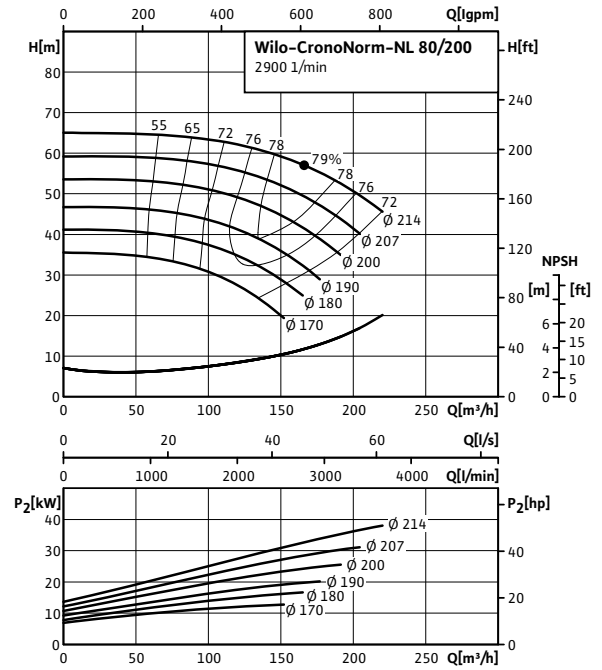

Wilo-CronoNorm-NL 80/250

Speed 2900 rpm

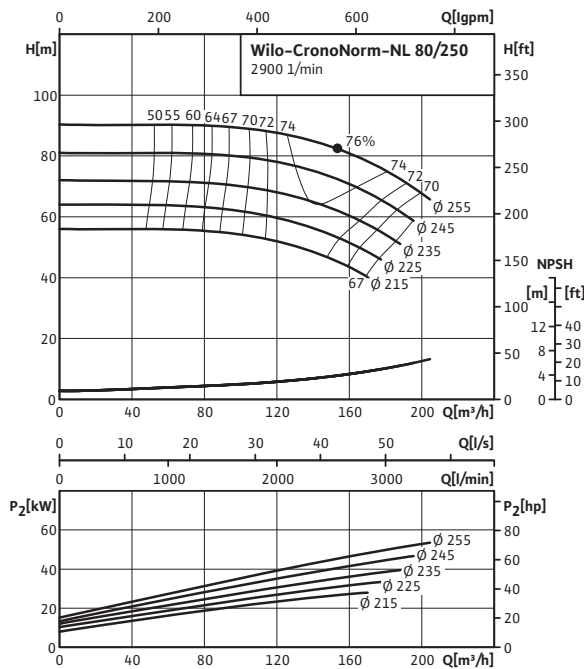

Wilo-CronoNorm-NL 100/160

Speed 2900 rpm

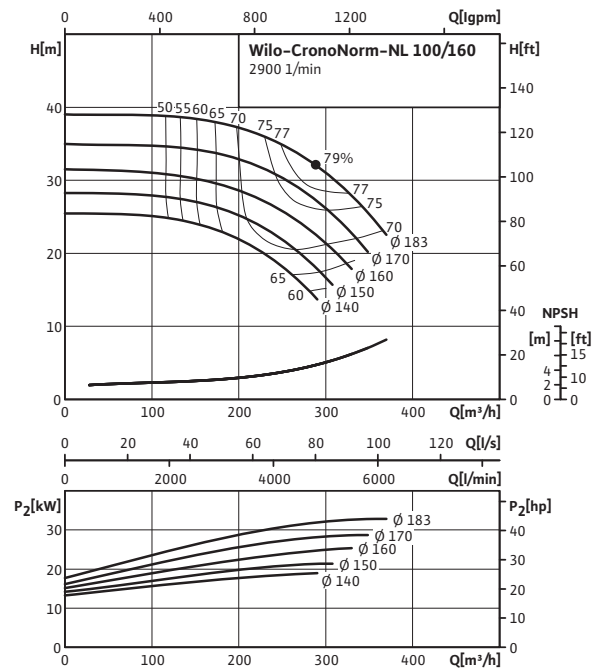

Norm pumps

Single pumps (heating, air-conditioning, cooling and industry)

Pump curves Wilo-CronoNorm-NL (2-pole)

Wilo-CronoNorm-NL 100/200

Speed 2900 rpm

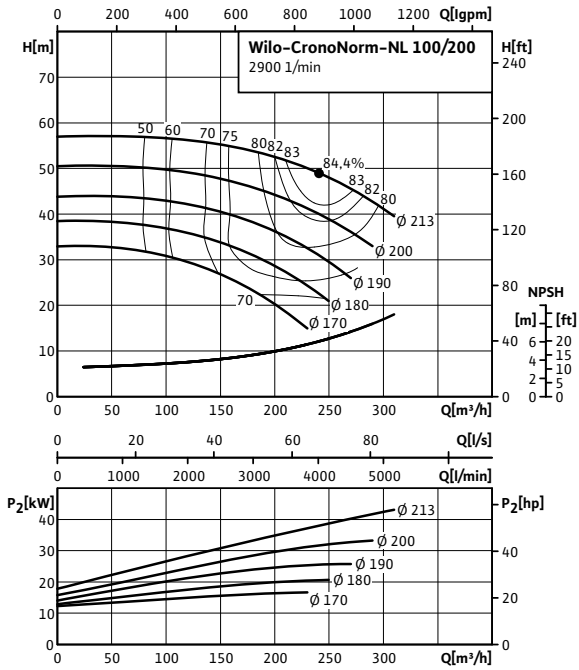

Wilo-CronoNorm-NL 100/250

Speed 2900 rpm

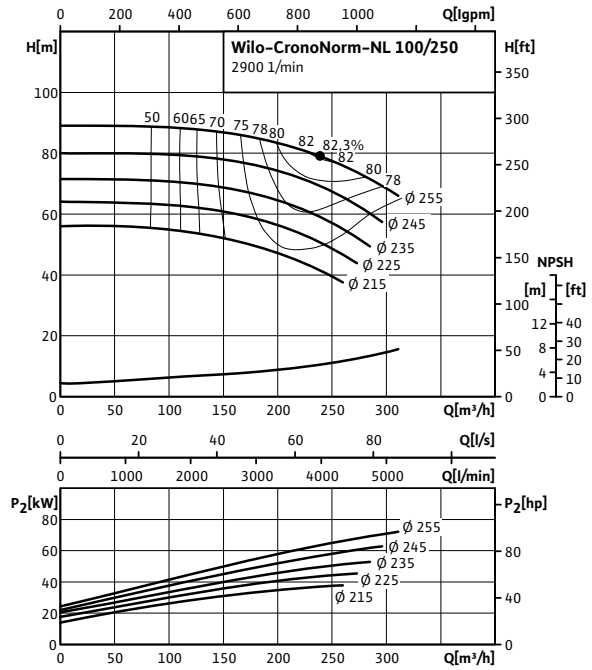

Wilo-CronoNorm-NL 125/200

Speed 2900 rpm

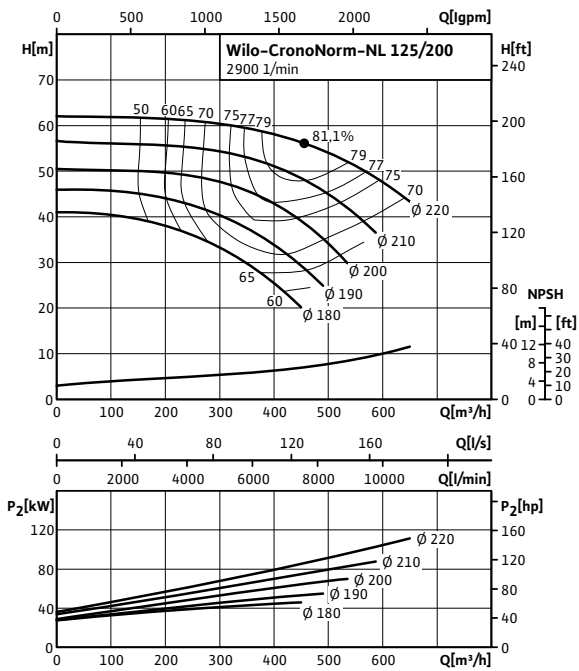

Norm pumps

Single pumps (heating, air-conditioning, cooling and industry)



Pump curves Wilo-CronoNorm-NL (4-pole)

Wilo-CronoNorm-NL 32/125

Speed 1450 rpm

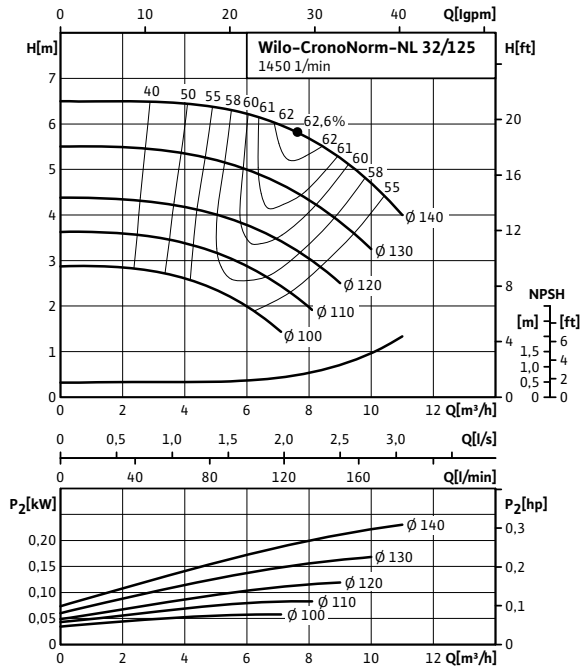

Wilo-CronoNorm-NL 32/160

Speed 1450 rpm

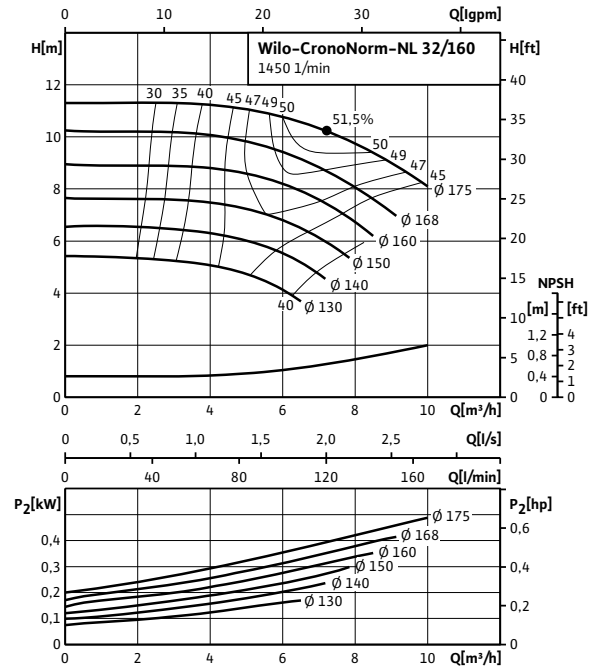

Wilo-CronoNorm-NL 32/160B

Speed 1450 rpm

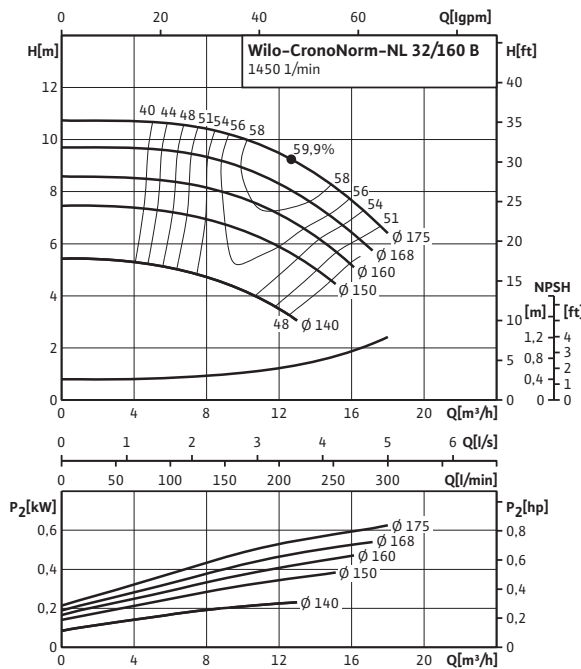

Wilo-CronoNorm-NL 32/200

Speed 1450 rpm

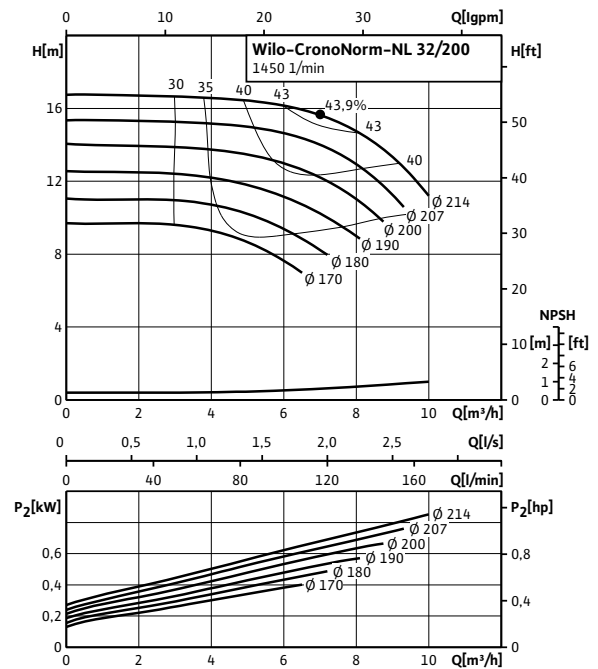

Norm pumps

Single pumps (heating, air-conditioning, cooling and industry)

Pump curves Wilo-CronoNorm-NL (4-pole)

Wilo-CronoNorm-NL 32/200B

Speed 1450 rpm

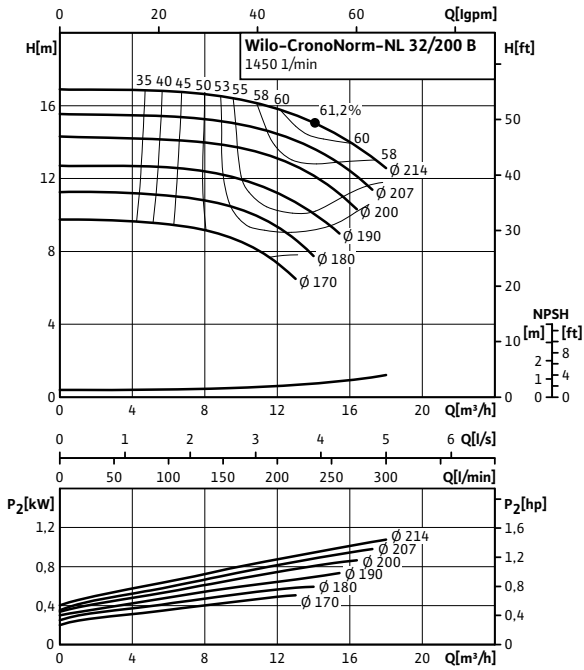

Wilo-CronoNorm-NL 32/250

Speed 1450 rpm

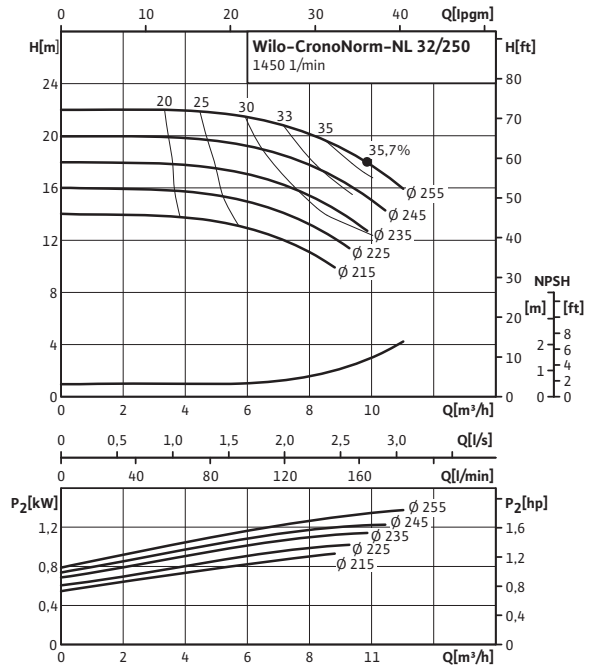

Wilo-CronoNorm-NL 40/125

Speed 1450 rpm

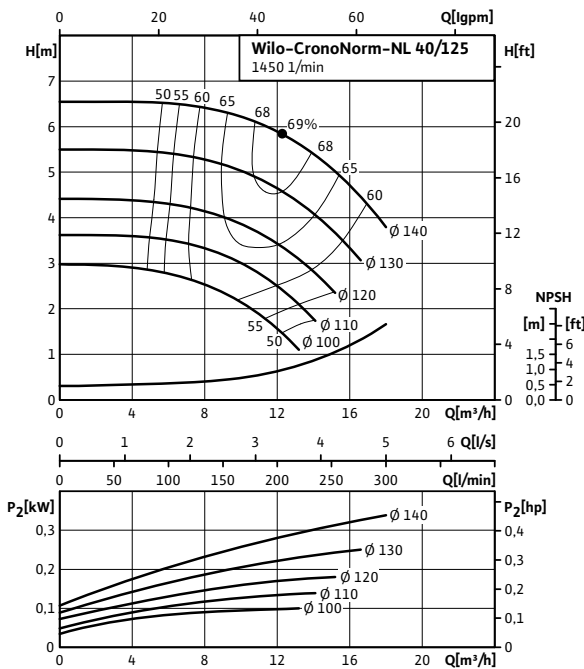

Wilo-CronoNorm-NL 40/160

Speed 1450 rpm

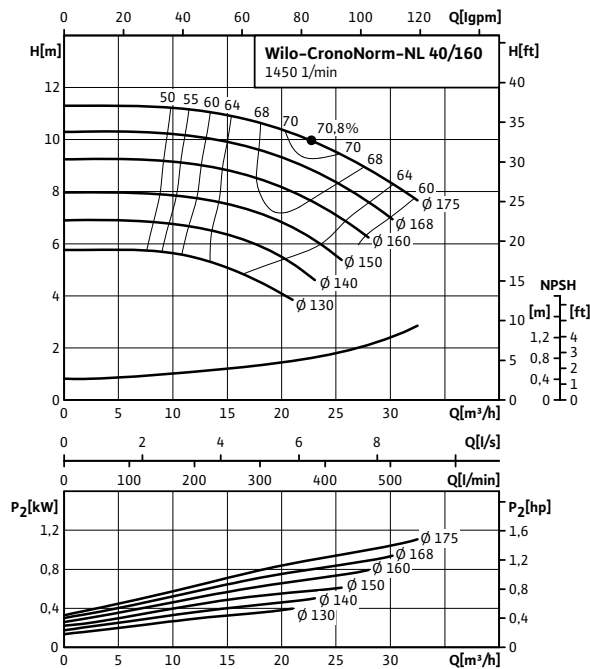

Norm pumps

Single pumps (heating, air-conditioning, cooling and industry)



Pump curves Wilo-CronoNorm-NL (4-pole)

Wilo-CronoNorm-NL 40/200

Speed 1450 rpm

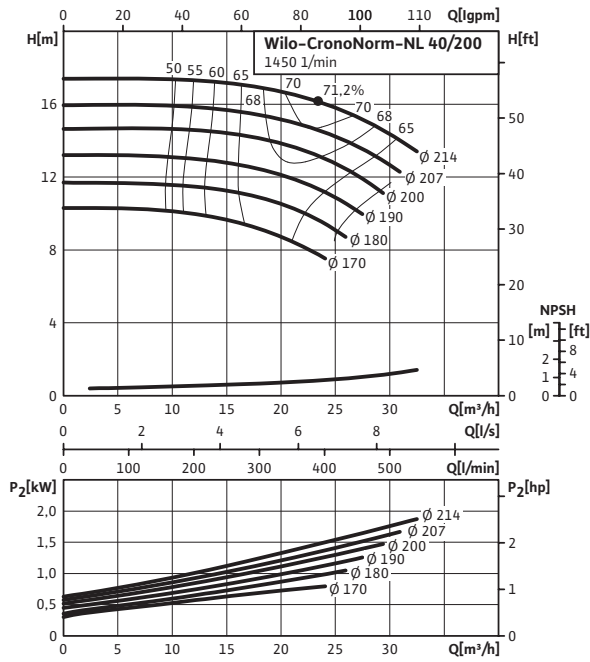

Wilo-CronoNorm-NL 40/250

Speed 1450 rpm

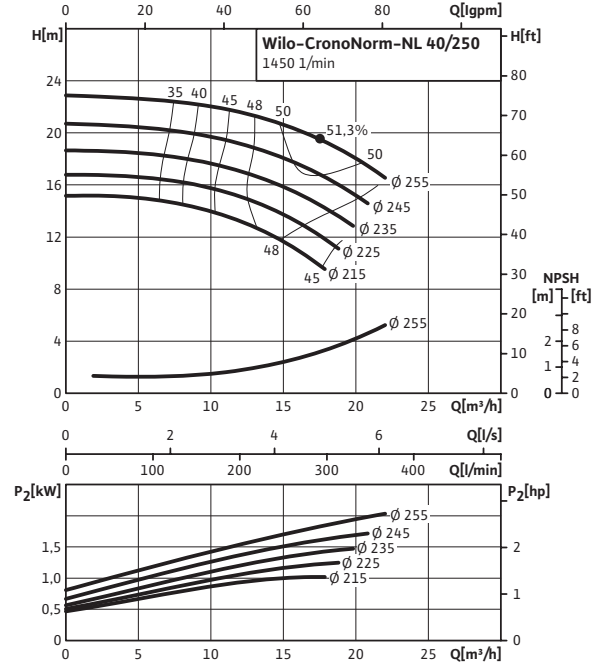

Wilo-CronoNorm-NL 40/315

Speed 1450 rpm

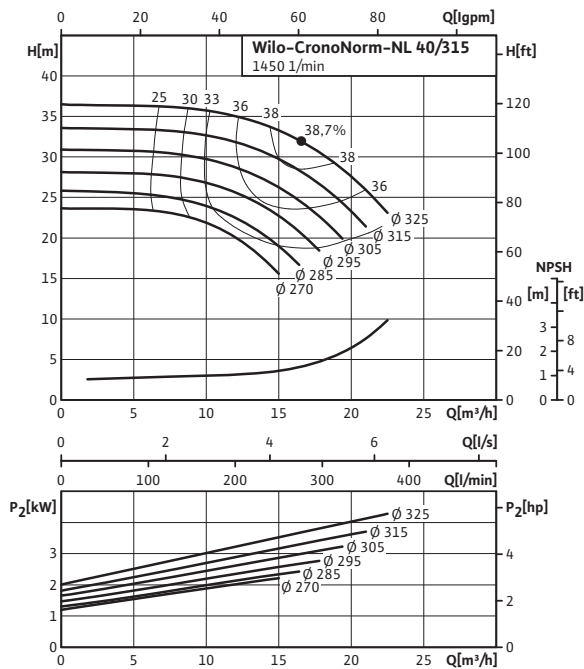

Wilo-CronoNorm-NL 50/125

Speed 1450 rpm

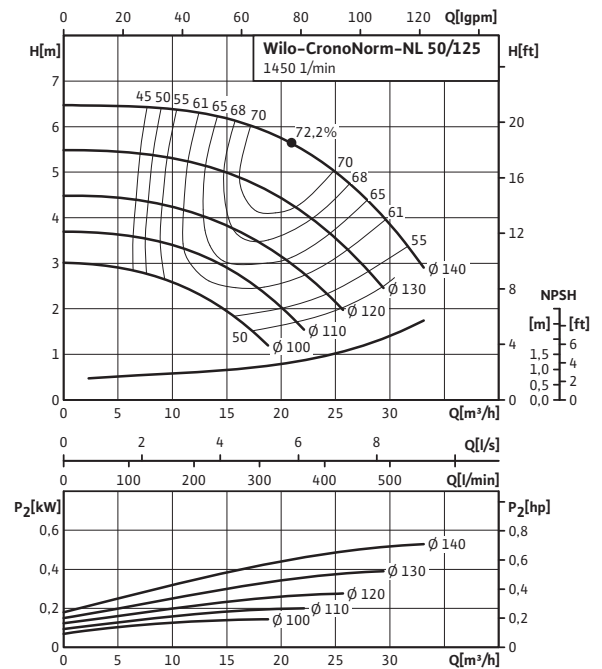

Norm pumps

Single pumps (heating, air-conditioning, cooling and industry)

Pump curves Wilo-CronoNorm-NL (4-pole)

Wilo-CronoNorm-NL 50/160

Speed 1450 rpm

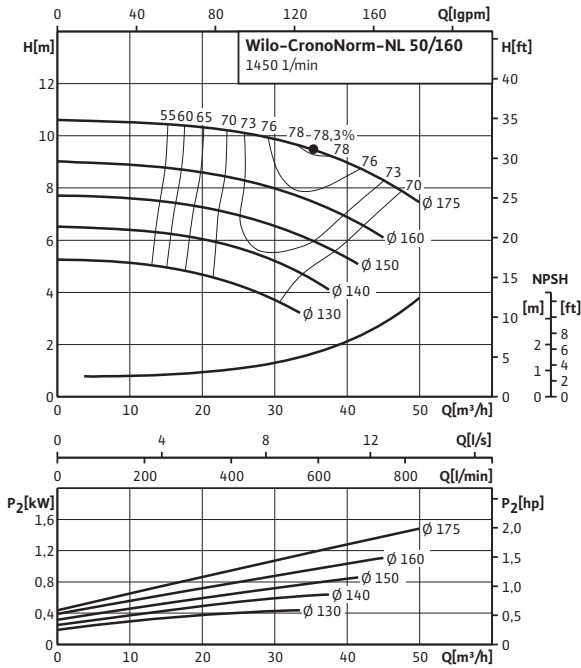

Wilo-CronoNorm-NL 50/200

Speed 1450 rpm

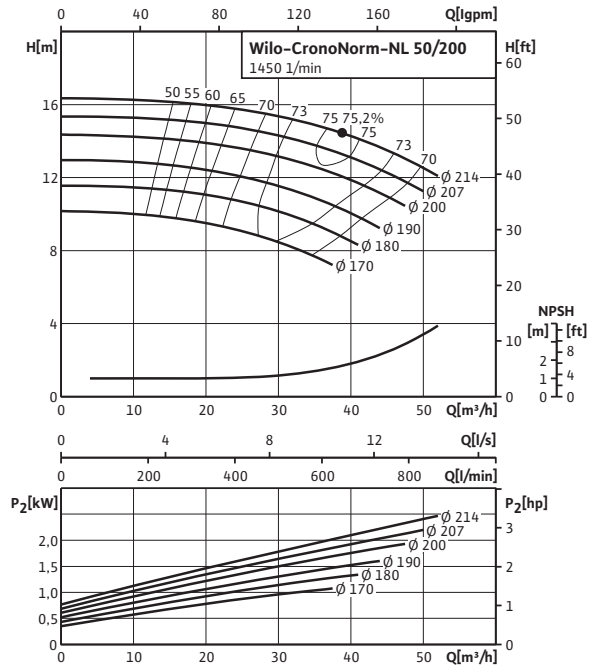

Wilo-CronoNorm-NL 50/250

Speed 1450 rpm

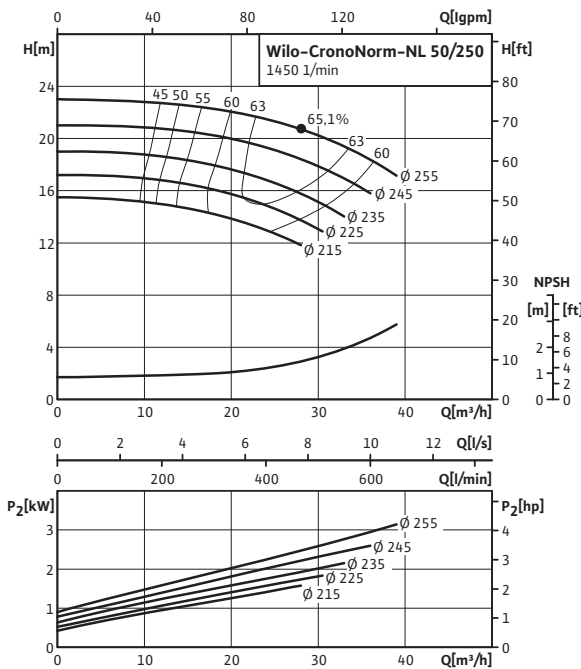

Wilo-CronoNorm-NL 50/315

Speed 1450 rpm

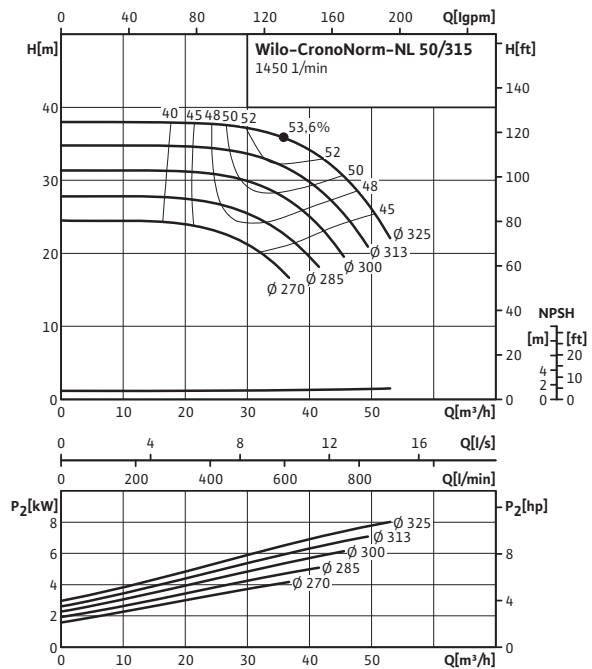

Norm pumps

Single pumps (heating, air-conditioning, cooling and industry)



Pump curves Wilo-CronoNorm-NL (4-pole)

Wilo-CronoNorm-NL 65/125

Speed 1450 rpm

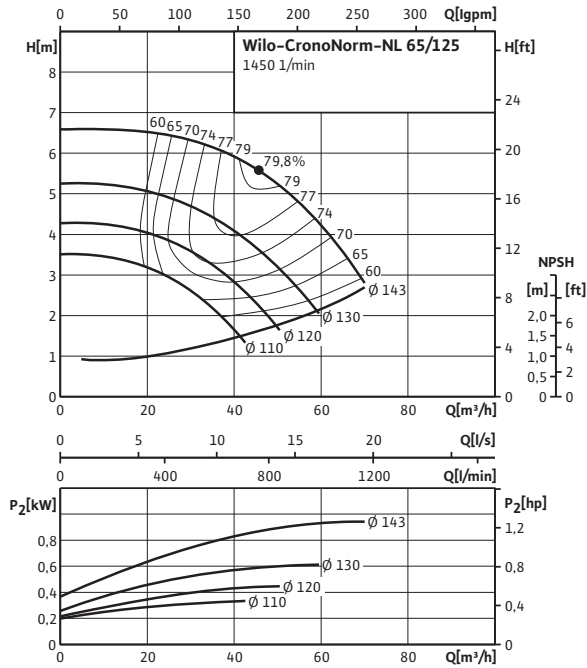

Wilo-CronoNorm-NL 65/160

Speed 1450 rpm

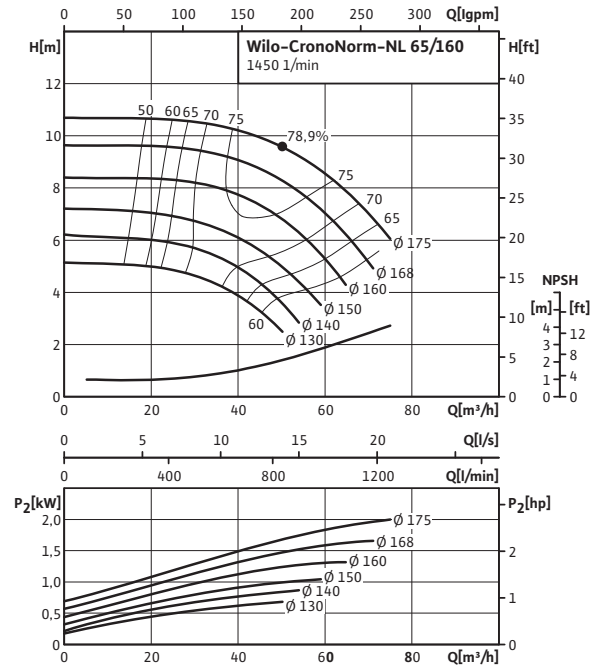

Wilo-CronoNorm-NL 65/200

Speed 1450 rpm

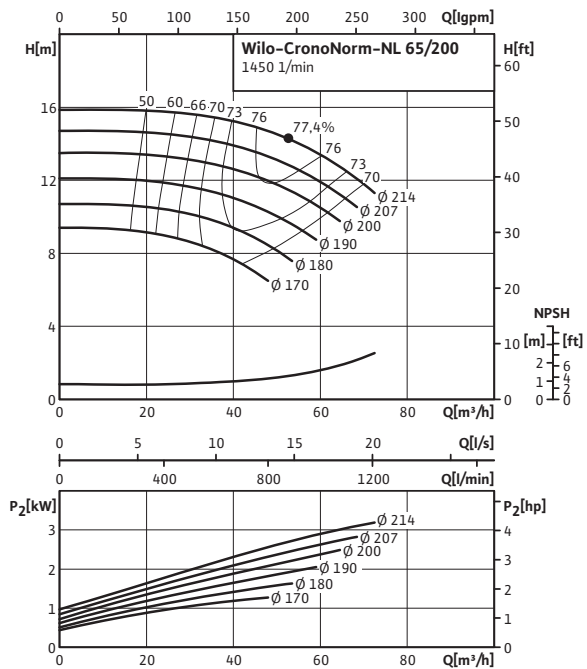

Wilo-CronoNorm-NL 65/250

Speed 1450 rpm

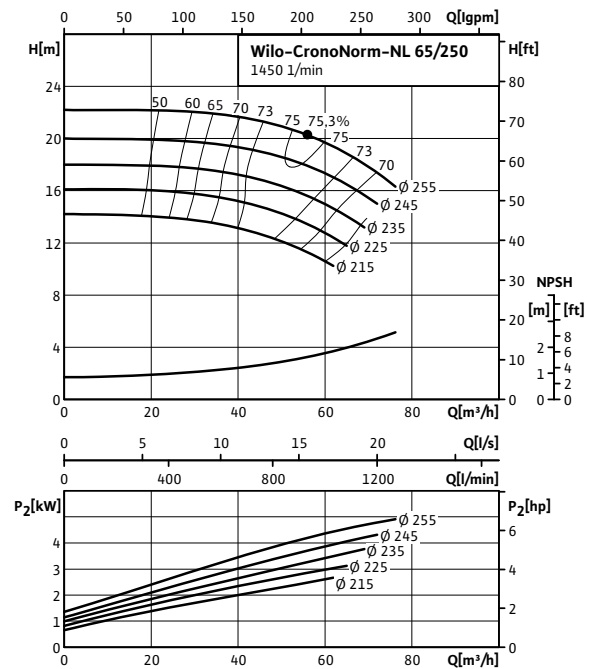

Norm pumps

Single pumps (heating, air-conditioning, cooling and industry)

Pump curves Wilo-CronoNorm-NL (4-pole)

Wilo-CronoNorm-NL 65/315

Speed 1450 rpm

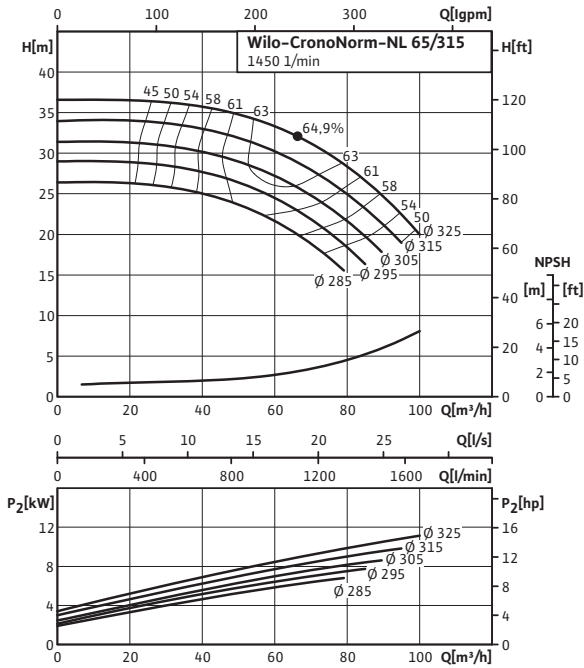

Wilo-CronoNorm-NL 80/160

Speed 1450 rpm

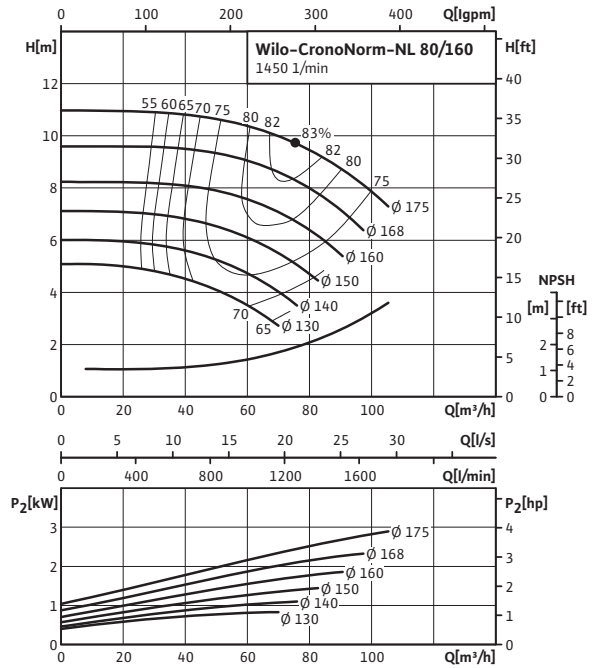

Wilo-CronoNorm-NL 80/200

Speed 1450 rpm

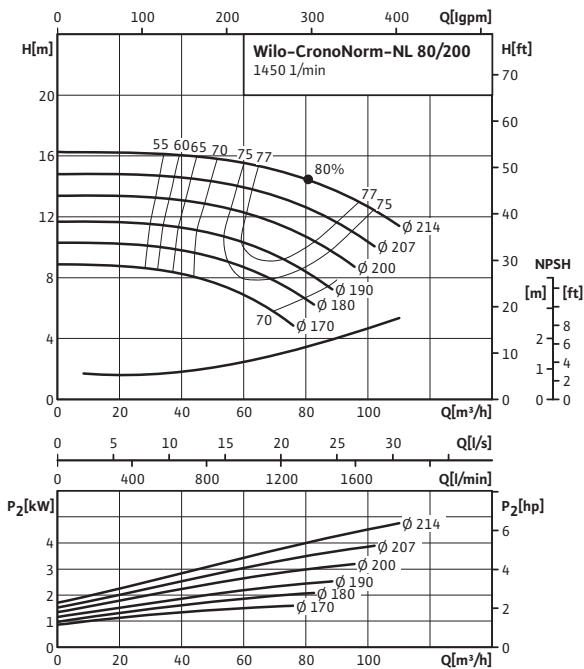

Wilo-CronoNorm-NL 80/250

Speed 1450 rpm

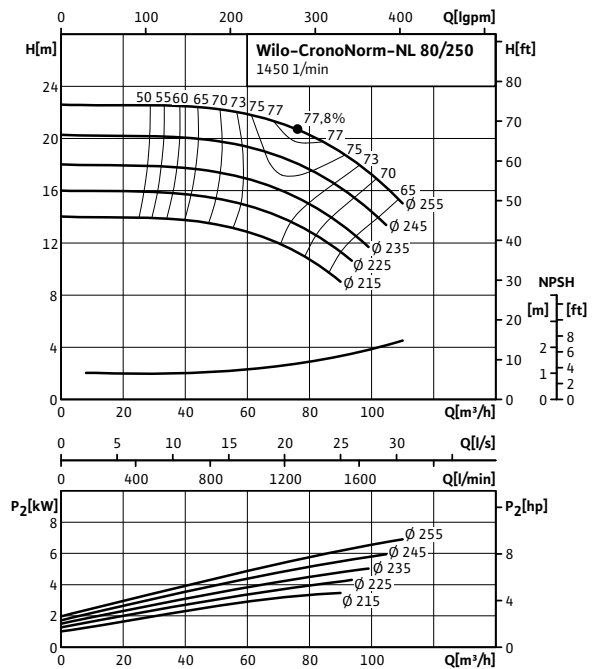

Norm pumps

Single pumps (heating, air-conditioning, cooling and industry)



Pump curves Wilo-CronoNorm-NL (4-pole)

Wilo-CronoNorm-NL 80/315

Speed 1450 rpm

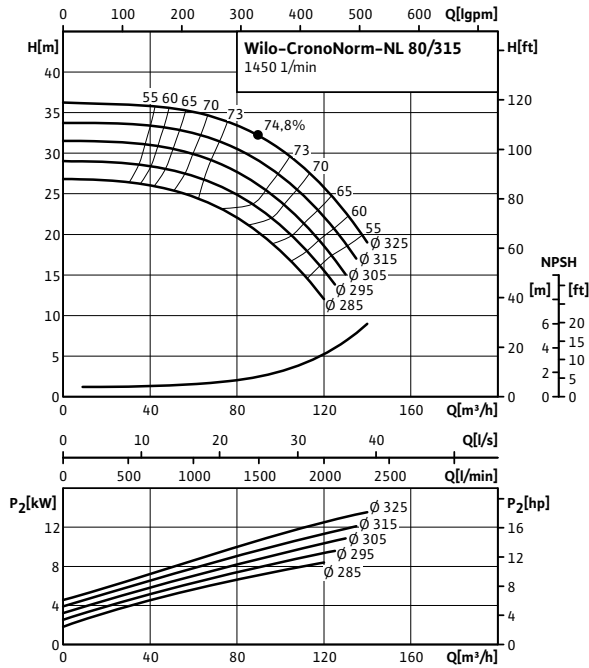

Wilo-CronoNorm-NL 80/400

Speed 1450 rpm

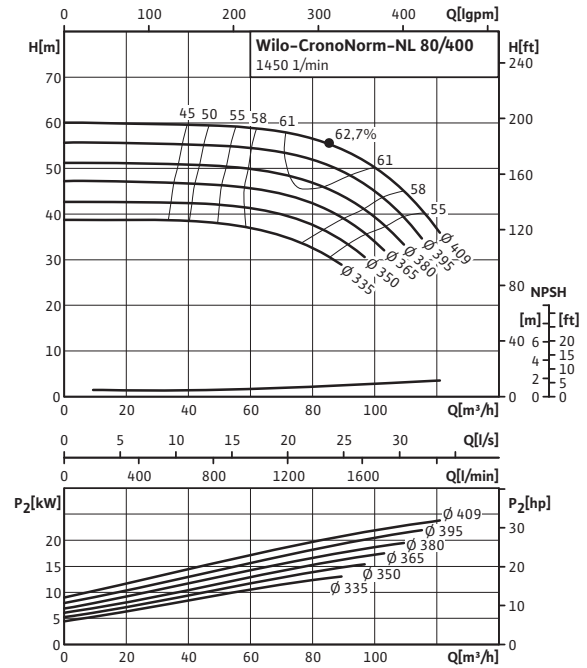

Wilo-CronoNorm-NL 100/160

Speed 1450 rpm

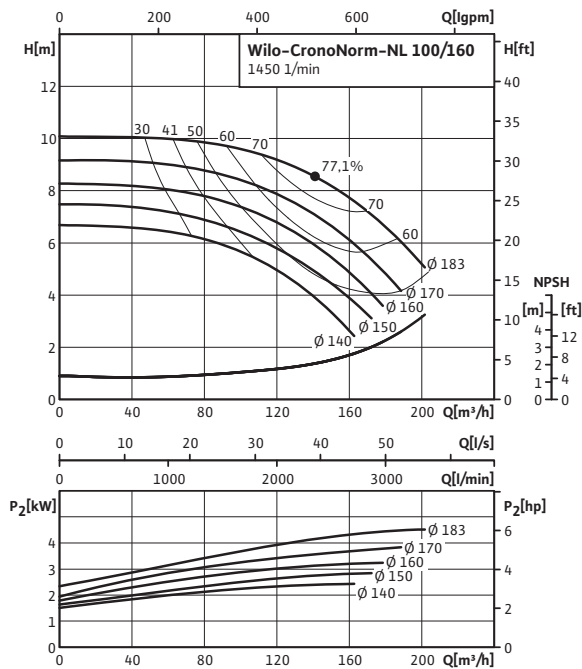

Wilo-CronoNorm-NL 100/200

Speed 1450 rpm

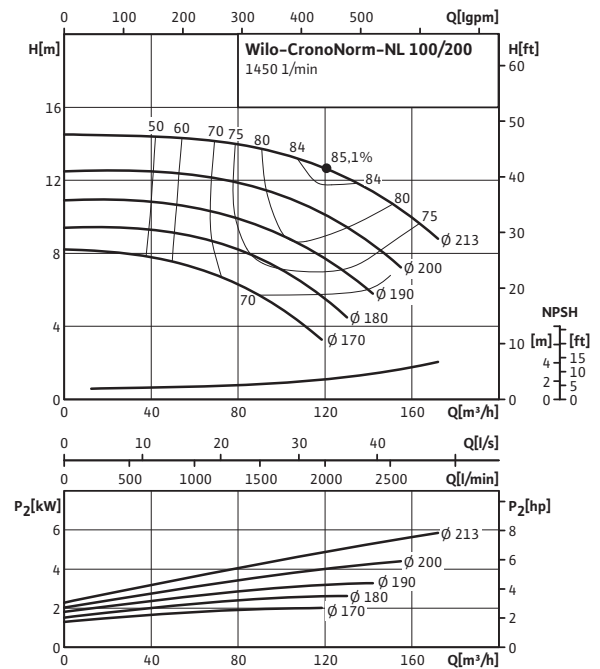

Norm pumps

Single pumps (heating, air-conditioning, cooling and industry)

Pump curves Wilo-CronoNorm-NL (4-pole)

Wilo-CronoNorm-NL 100/250

Speed 1450 rpm

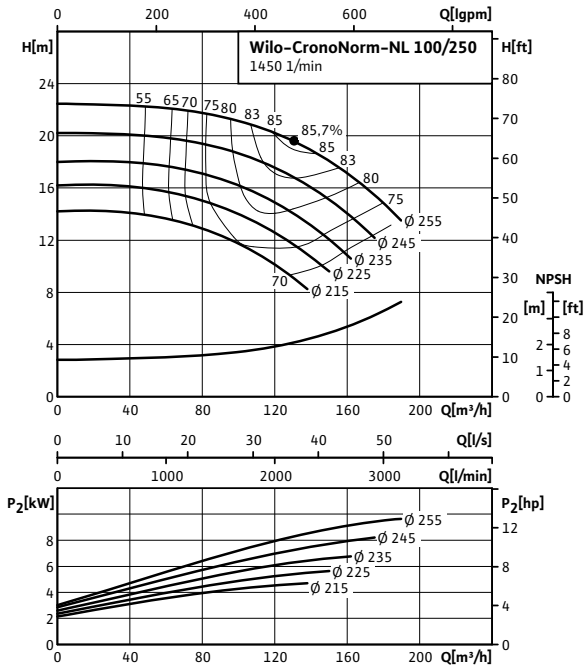

Wilo-CronoNorm-NL 100/315

Speed 1450 rpm

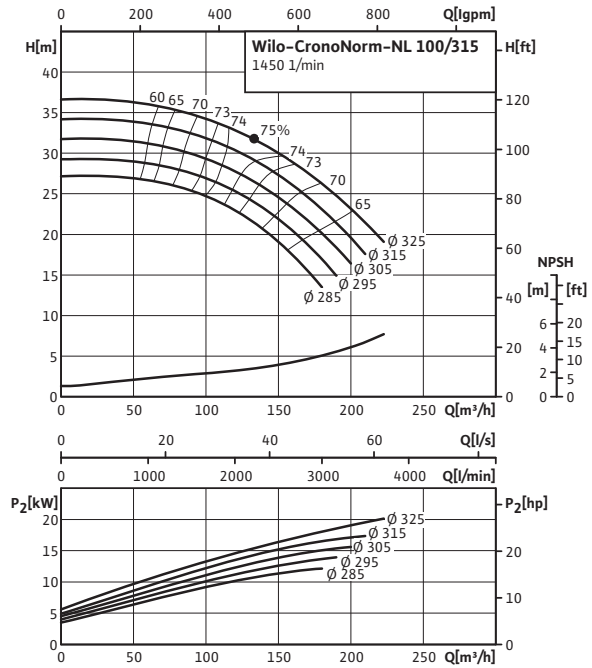

Wilo-CronoNorm-NL 100/400

Speed 1450 rpm

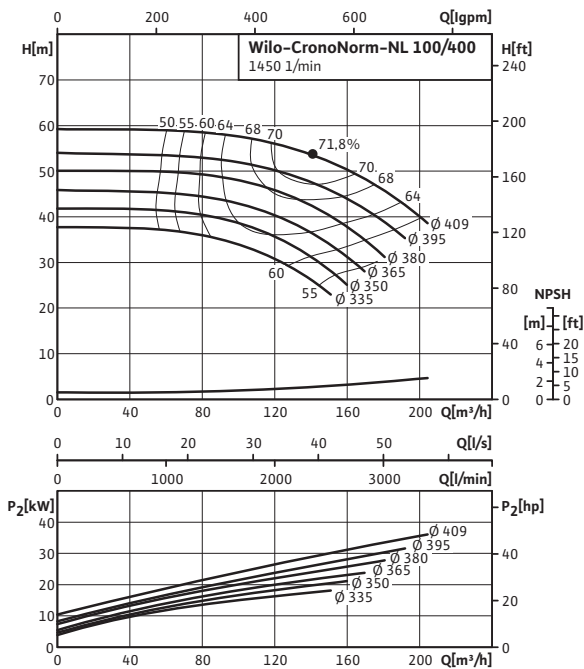

Wilo-CronoNorm-NL 125/200

Speed 1450 rpm

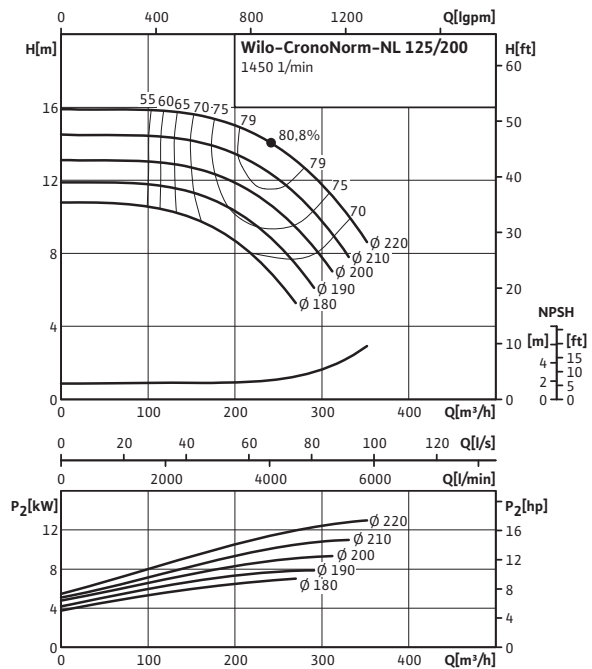

Norm pumps

Single pumps (heating, air-conditioning, cooling and industry)



Pump curves Wilo-CronoNorm-NL (4-pole)

Wilo-CronoNorm-NL 125/250

Speed 1450 rpm

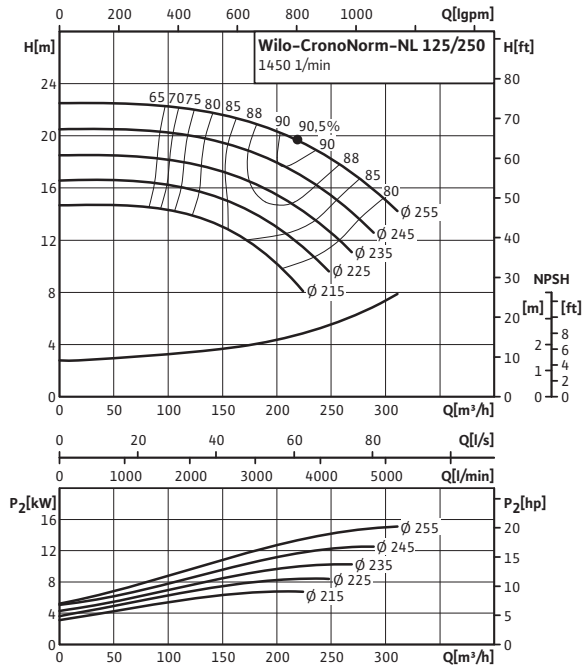

Wilo-CronoNorm-NL 125/315

Speed 1450 rpm

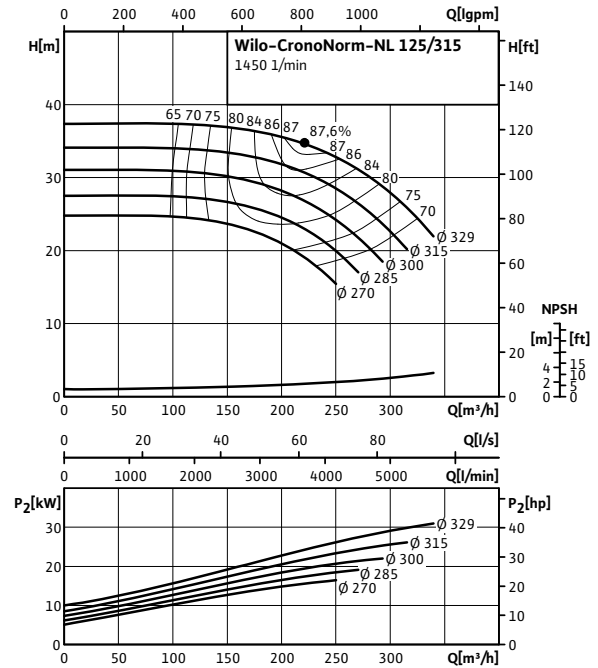

Wilo-CronoNorm-NL 125/400

Speed 1450 rpm

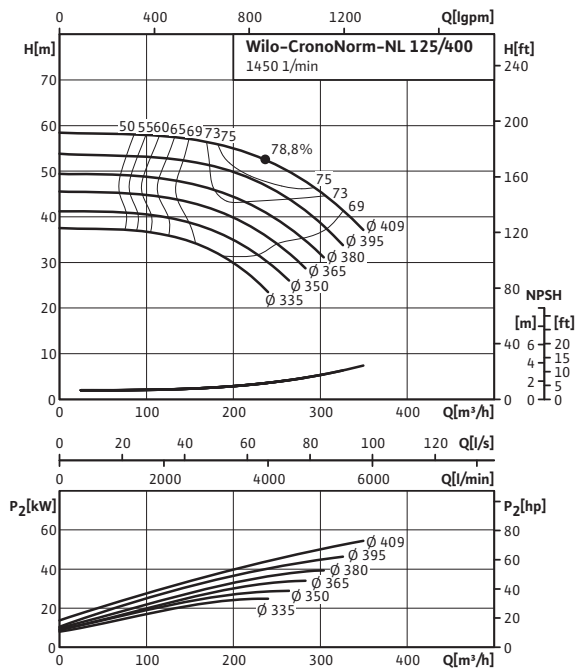

Wilo-CronoNorm-NL 150/200

Speed 1450 rpm

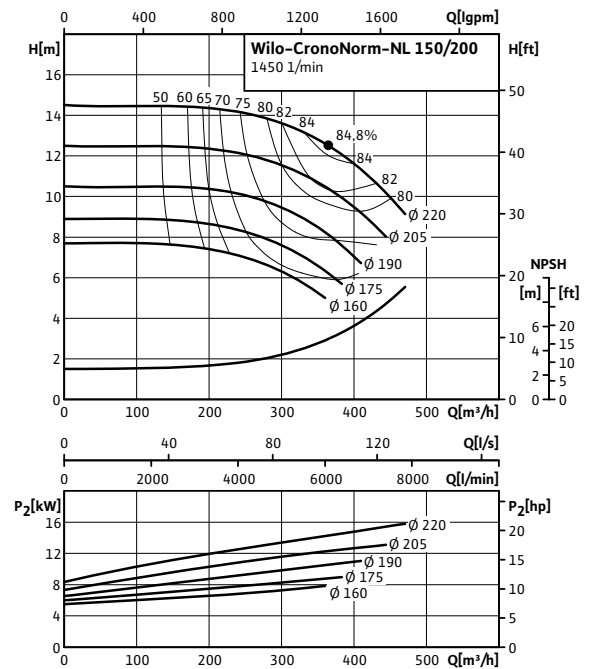

Norm pumps

Single pumps (heating, air-conditioning, cooling and industry)

Pump curves Wilo-CronoNorm-NL (4-pole)

Wilo-CronoNorm-NL 150/250

Speed 1450 rpm

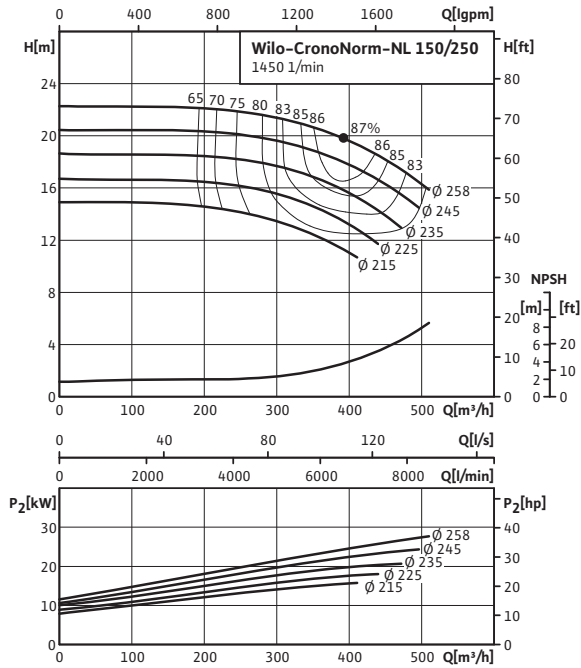

Wilo-CronoNorm-NL 150/315

Speed 1450 rpm

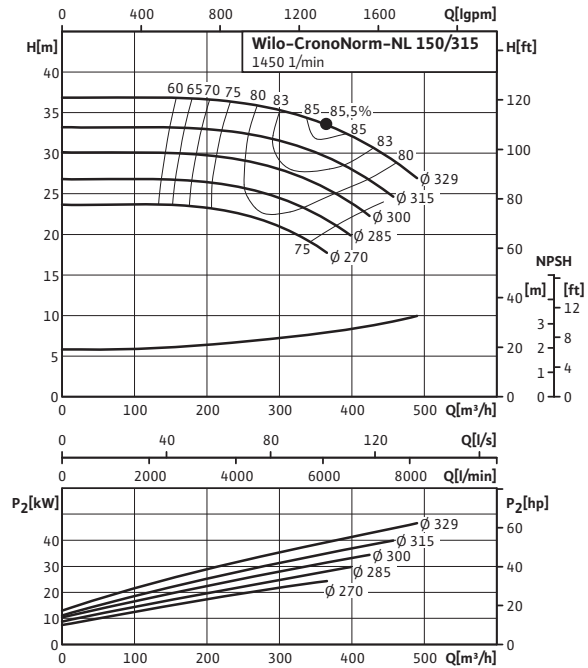

Wilo-CronoNorm-NL 150/400

Speed 1450 rpm

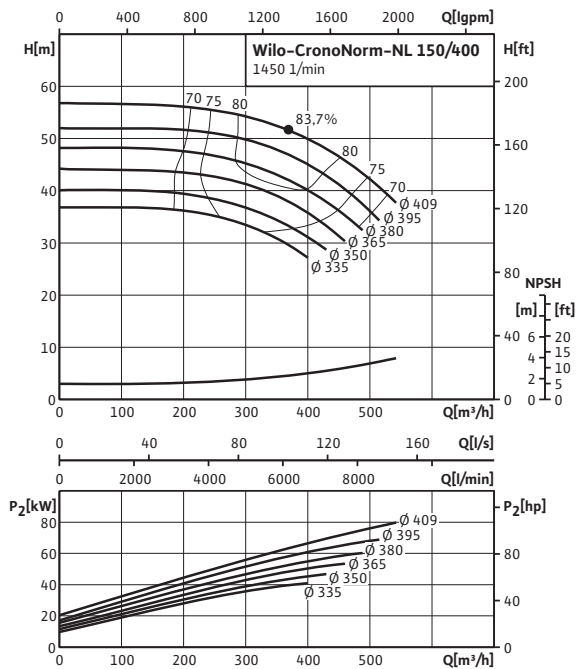

Norm pumps

Single pumps (heating, air-conditioning, cooling and industry)



Dimensions, weights Wilo-CronoNorm-NL (with spacer coupling)

Dimension drawing

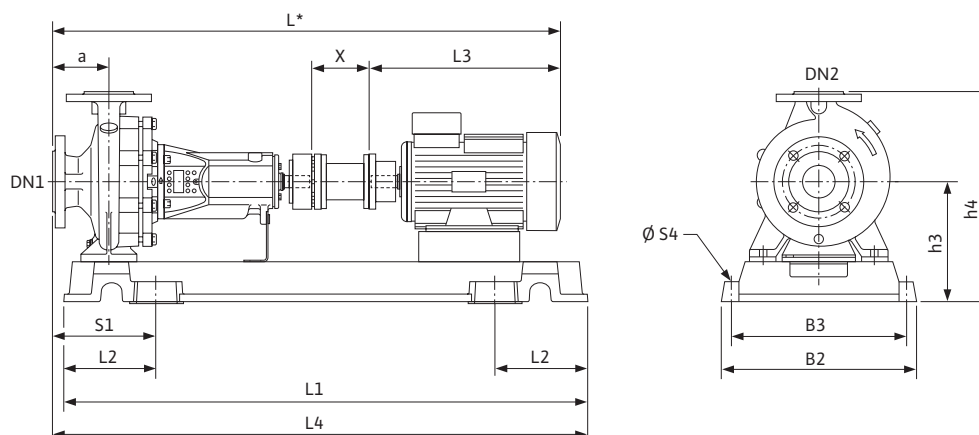

The length and width of the base block should be approx. 15 to 20 cm greater than the outer dimensions of the pump baseplate. Dimensions L*, L3: approximate dimension, since this depends on the make of the motor.

Motor data (1450 rpm; with spacer coupling)

	Nominal motor power	Motor size	Nominal diameter		Dimensions													Weight approx.
	P ₂	—	DN ₁	DN ₂	A ₂	H ₄	H ₃	S ₄	L ₂	L ₁	L	L ₃	L ₄	S ₁	B ₃	B ₂	X	M
	[W]	[MG]	[mm]															
32/125	0.37	71	50	32	80	332	192	19	150	840	800	260	845	155	320	360	100	89
32/160	0.37	71	50	32	80	372	212	19	150	840	800	260	845	155	320	360	100	91
32/160	0.55	80	50	32	80	372	212	19	150	840	835	295	845	155	320	360	100	94
32/160	0.75	80	50	32	80	372	212	19	150	840	835	295	845	155	320	360	100	96
32/160B	0.37	71	50	32	80	372	212	19	150	840	800	260	845	155	320	360	100	91
32/160B	0.55	80	50	32	80	372	212	19	150	840	835	295	845	155	320	360	100	94
32/160B	0.75	80	50	32	80	372	212	19	150	840	835	295	845	155	320	360	100	96
32/200	0.55	80	50	32	80	420	240	19	150	840	835	295	845	155	320	360	100	95
32/200	0.75	80	50	32	80	420	240	19	150	840	835	295	845	155	320	360	100	97
32/200	1.1	90S	50	32	80	420	240	19	170	940	885	345	945	175	350	390	100	112
32/200	1.5	90L	50	32	80	420	240	19	170	940	885	345	945	175	350	390	100	115
32/200B	0.55	80	50	32	80	420	240	19	150	840	835	295	845	155	320	360	100	95
32/200B	0.75	80	50	32	80	420	240	19	150	840	835	295	845	155	320	360	100	97
32/200B	1.1	90S	50	32	80	420	240	19	170	940	885	345	945	175	350	390	100	112
32/200B	1.5	90L	50	32	80	420	240	19	170	940	885	345	945	175	350	390	100	115
32/250	0.75	80	50	32	100	505	280	24	190	1040	855	295	1050	200	400	450	100	132
32/250	1.1	90S	50	32	100	505	280	24	190	1040	905	345	1050	200	400	450	100	137
32/250	1.5	90L	50	32	100	505	280	24	190	1040	905	345	1050	200	400	450	100	140
32/250	2.2	100L	50	32	100	505	280	24	190	1040	940	380	1050	200	400	450	100	149
40/125	0.37	71	65	40	80	332	192	19	150	840	800	260	845	155	320	360	100	86
40/125	0.55	80	65	40	80	332	192	19	150	840	835	295	845	155	320	360	100	89
40/160	0.37	71	65	40	80	372	212	19	150	840	800	260	845	155	320	360	100	88
40/160	0.55	80	65	40	80	372	212	19	150	840	835	295	845	155	320	360	100	91
40/160	0.75	80	65	40	80	372	212	19	150	840	835	295	845	155	320	360	100	93
40/160	1.1	90S	65	40	80	372	212	19	150	840	885	345	845	155	320	360	100	97

Norm pumps

Single pumps (heating, air-conditioning, cooling and industry)

Dimensions, weights Wilo-CronoNorm-NL (with spacer coupling)

Motor data (1450 rpm; with spacer coupling)

	Nominal motor power	Motor size	Nominal diameter		Dimensions													Weight approx.
	P ₂	–	DN ₁	DN ₂	A ₂	H ₄	H ₃	S ₄	L ₂	L ₁	L	L ₃	L ₄	S1	B3	B2	X	M
	[W]	[MG]	[mm]															[kg]
40/160	1.5	90L	65	40	80	372	212	19	170	940	885	345	945	175	350	390	100	111
40/200	0.55	80	65	40	100	420	240	19	170	940	855	295	965	195	350	390	100	108
40/200	0.75	80	65	40	100	420	240	19	170	940	855	295	965	195	350	390	100	109
40/200	1.1	90S	65	40	100	420	240	19	170	940	905	345	965	195	350	390	100	114
40/200	1.5	90L	65	40	100	420	240	19	170	940	905	345	965	195	350	390	100	117
40/200	2.2	100L	65	40	100	420	240	19	170	940	940	380	965	195	350	390	100	126
40/250	1.1	90S	65	40	100	505	280	24	190	1040	905	345	1050	200	400	450	100	137
40/250	1.5	90L	65	40	100	505	280	24	190	1040	905	345	1050	200	400	450	100	140
40/250	2.2	100L	65	40	100	505	280	24	190	1040	940	380	1050	200	400	450	100	149
40/250	3	100L	65	40	100	505	280	24	190	1040	940	380	1050	200	400	450	100	152
40/315	2.2	100L	65	40	125	575	325	24	210	1160	1075	380	1195	245	440	490	100	212
40/315	3	100L	65	40	125	575	325	24	210	1160	1075	380	1195	245	440	490	100	215
40/315	4	112M	65	40	125	575	325	24	210	1160	1155	460	1195	245	440	490	100	228
40/315	5.5	123S	65	40	125	575	325	24	210	1160	1210	515	1195	245	440	490	100	243
50/125	0.37	71	65	50	100	372	212	19	150	840	820	260	865	175	320	360	100	88
50/125	0.55	80	65	50	100	372	212	19	150	840	855	295	865	175	320	360	100	91
50/125	0.75	80	65	50	100	372	212	19	150	840	855	295	865	175	320	360	100	93
50/160	0.55	80	65	50	100	420	240	19	170	940	855	295	965	195	350	390	100	108
50/160	0.75	80	65	50	100	420	240	19	170	940	855	295	965	195	350	390	100	109
50/160	1.1	90S	65	50	100	420	240	19	170	940	905	345	965	195	350	390	100	114
50/160	1.5	90L	65	50	100	420	240	19	170	940	905	345	965	195	350	390	100	117
50/160	2.2	100L	65	50	100	420	240	19	170	940	940	380	965	195	350	390	100	126
50/200	1.1	90S	65	50	100	440	240	19	170	940	905	345	965	195	350	390	100	118
50/200	1.5	90L	65	50	100	440	240	19	170	940	905	345	965	195	350	390	100	122
50/200	2.2	100L	65	50	100	440	240	19	170	940	940	380	965	195	350	390	100	130
50/200	3	100L	65	50	100	440	240	19	170	940	940	380	965	195	350	390	100	133
50/250	1.5	90L	65	50	100	505	280	24	190	1040	905	345	1050	200	400	450	100	145
50/250	2.2	100L	65	50	100	505	280	24	190	1040	940	380	1050	200	400	450	100	153
50/250	3	100L	65	50	100	505	280	24	190	1040	940	380	1050	200	400	450	100	156
50/250	4	112M	65	50	100	505	280	24	190	1040	1020	460	1050	200	400	450	100	169
50/315	4	112M	65	50	125	605	325	24	210	1160	1155	460	1195	245	440	490	100	243
50/315	5.5	123S	65	50	125	605	325	24	210	1160	1210	515	1195	245	440	490	100	259
50/315	7.5	132M	65	50	125	605	325	24	210	1160	1225	530	1195	245	440	490	100	268
50/315	9	132M	65	50	125	605	325	24	210	1160	1225	530	1195	245	440	490	100	273
65/125	0.55	80	80	65	100	420	240	19	170	940	855	295	965	195	350	390	100	105
65/125	0.75	80	80	65	100	420	240	19	170	940	855	295	965	195	350	390	100	106
65/125	1.1	90S	80	65	100	440	260	24	190	1040	905	345	1065	215	400	450	100	123
65/160	0.75	80	80	65	100	440	240	19	170	940	855	295	965	195	350	390	100	112
65/160	1.5	90L	80	65	100	440	240	19	170	940	905	345	965	195	350	390	100	121
65/160	2.2	100L	80	65	100	440	240	19	170	940	940	380	965	195	350	390	100	129
65/200	1.1	90S	80	65	100	505	280	24	190	1040	905	345	1050	200	400	450	100	136
65/200	1.5	90L	80	65	100	505	280	24	190	1040	905	345	1050	200	400	450	100	139
65/200	2.2	100L	80	65	100	505	280	24	190	1040	940	380	1050	200	400	450	100	148

Norm pumps

Single pumps (heating, air-conditioning, cooling and industry)



Dimensions, weights Wilo-CronoNorm-NL (with spacer coupling)

Motor data (1450 rpm; with spacer coupling)

	Nominal motor power	Motor size	Nominal diameter		Dimensions													Weight approx.
	P ₂	–	DN ₁	DN ₂	A ₂	H ₄	H ₃	S ₄	L ₂	L ₁	L	L ₃	L ₄	S1	B3	B2	X	M
	[W]	[MG]	[mm]															
65/200	3	100L	80	65	100	505	280	24	190	1040	940	380	1050	200	400	450	100	151
65/200	4	112M	80	65	100	505	280	24	190	1040	1020	460	1050	200	400	450	100	164
65/250	2.2	100L	80	65	100	550	300	24	210	1160	1050	380	1155	205	440	490	100	209
65/250	3	100L	80	65	100	550	300	24	210	1160	1050	380	1155	205	440	490	100	212
65/250	4	112M	80	65	100	550	300	24	210	1160	1130	460	1155	205	440	490	100	224
65/250	5.5	123S	80	65	100	550	300	24	210	1160	1185	515	1155	205	440	490	100	240
65/315	5.5	123S	80	65	125	605	325	24	235	1310	1210	515	1325	250	490	540	100	295
65/315	7.5	132M	80	65	125	605	325	24	235	1310	1225	530	1325	250	490	540	100	303
65/315	9	132M	80	65	125	605	325	24	235	1310	1225	530	1325	250	490	540	100	309
65/315	11	160M	80	65	125	605	325	24	235	1310	1320	625	1325	250	490	540	100	342
65/315	15	160L	80	65	125	605	325	29	260	1460	1365	670	1475	275	550	610	100	409
80/160	1.1	90S	100	80	125	505	280	24	190	1040	970	345	1075	225	400	450	140	134
80/160	1.5	90L	100	80	125	505	280	24	190	1040	970	345	1075	225	400	450	140	137
80/160	2.2	100L	100	80	125	505	280	24	190	1040	1005	380	1075	225	400	450	140	146
80/160	3	100L	100	80	125	505	280	24	190	1040	1005	380	1075	225	400	450	140	149
80/160	4	112M	100	80	125	505	280	24	190	1040	1085	460	1075	225	400	450	140	161
80/200	1.5	90L	100	80	125	530	280	24	210	1160	1080	345	1195	245	440	490	140	190
80/200	2.2	100L	100	80	125	530	280	24	210	1160	1115	380	1195	245	440	490	140	198
80/200	3	100L	100	80	125	530	280	24	210	1160	1115	380	1195	245	440	490	140	201
80/200	4	112M	100	80	125	530	280	24	210	1160	1195	460	1195	245	440	490	140	214
80/200	5.5	123S	100	80	125	530	280	24	210	1160	1250	515	1195	245	440	490	140	230
80/250	3	100L	100	80	125	580	300	24	235	1310	1115	380	1325	250	490	540	140	249
80/250	4	112M	100	80	125	580	300	24	235	1310	1195	460	1325	250	490	540	140	261
80/250	5.5	123S	100	80	125	580	300	24	235	1310	1250	515	1325	250	490	540	140	277
80/250	7.5	132M	100	80	125	580	300	24	235	1310	1265	530	1325	250	490	540	140	285
80/315	5.5	123S	100	80	125	665	350	24	235	1310	1250	515	1325	250	490	540	140	298
80/315	7.5	132M	100	80	125	665	350	24	235	1310	1265	530	1325	250	490	540	140	306
80/315	9	132M	100	80	125	665	350	24	235	1310	1265	530	1325	250	490	540	140	312
80/315	11	160M	100	80	125	665	350	24	235	1310	1360	625	1325	250	490	540	140	345
80/315	15	160L	100	80	125	665	350	24	235	1310	1405	670	1325	250	490	540	140	365
80/400	11	160M	125	80	125	735	380	29	260	1460	1420	625	1475	275	550	610	140	443
80/400	15	160L	125	80	125	735	380	29	260	1460	1465	670	1475	275	550	610	140	462
80/400	18.5	180M	125	80	125	735	380	29	260	1460	1495	700	1475	275	550	610	140	503
80/400	22	180L	125	80	125	735	380	29	260	1460	1535	740	1475	275	550	610	140	530
80/400	30	200L	125	80	125	735	380	29	260	1460	1595	800	1475	275	550	610	140	582
100/160	2.2	100L	125	100	125	580	300	24	210	1160	1115	380	1180	230	440	490	140	217
100/160	3	100L	125	100	125	580	300	24	210	1160	1115	380	1180	230	440	490	140	220
100/160	4	112M	125	100	125	580	300	24	210	1160	1195	460	1180	230	440	490	140	233
100/160	5.5	123S	125	100	125	580	300	24	210	1160	1250	515	1180	230	440	490	140	249
100/200	2.2	100L	125	100	125	580	300	24	210	1160	1115	380	1180	230	440	490	140	209
100/200	3	100L	125	100	125	580	300	24	210	1160	1115	380	1180	230	440	490	140	212
100/200	4	112M	125	100	125	580	300	24	210	1160	1195	460	1180	230	440	490	140	224
100/200	5.5	123S	125	100	125	580	300	24	210	1160	1250	515	1180	230	440	490	140	240

Norm pumps

Single pumps (heating, air-conditioning, cooling and industry)

Dimensions, weights Wilo-CronoNorm-NL (with spacer coupling)

Motor data (1450 rpm; with spacer coupling)

	Nominal motor power	Motor size	Nominal diameter		Dimensions													Weight approx.
	P ₂	–	DN ₁	DN ₂	A ₂	H ₄	H ₃	S ₄	L ₂	L ₁	L	L ₃	L ₄	S1	B3	B2	X	M
	[W]	[MG]	[mm]															
100/200	7.5	132M	125	100	125	580	300	24	210	1160	1265	530	1180	230	440	490	140	249
100/250	4	112M	125	100	140	605	325	24	235	1310	1210	460	1340	265	490	540	140	272
100/250	5.5	123S	125	100	140	605	325	24	235	1310	1265	515	1340	265	490	540	140	288
100/250	7.5	132M	125	100	140	605	325	24	235	1310	1280	530	1340	265	490	540	140	296
100/250	9	132M	125	100	140	605	325	24	235	1310	1280	530	1340	265	490	540	140	301
100/250	11	160M	125	100	140	605	325	24	235	1310	1375	625	1340	265	490	540	140	335
100/315	11	160M	125	100	140	665	350	24	235	1310	1375	625	1340	265	490	540	140	355
100/315	15	160L	125	100	140	665	350	24	235	1310	1420	670	1340	265	490	540	140	421
100/315	18.5	180M	125	100	140	665	350	29	260	1460	1450	700	1490	290	550	610	140	462
100/315	22	180L	125	100	140	665	350	29	260	1460	1490	740	1490	290	550	610	140	489
100/400	15	160L	125	100	140	755	400	29	300	1660	1420	670	1670	310	600	660	140	539
100/400	18.5	180M	125	100	140	755	400	29	300	1660	1450	700	1670	310	600	660	140	580
100/400	22	180L	125	100	140	755	400	29	300	1660	1490	740	1670	310	600	660	140	607
100/400	30	200L	125	100	140	755	400	29	300	1660	1550	800	1670	310	600	660	140	659
100/400	37	225S	125	100	140	755	400	29	300	1660	1620	870	1670	310	600	660	140	785
100/400	45	225M	125	100	140	755	400	29	300	1660	1620	870	1670	310	600	660	140	819
125/200	7.5	132M	150	125	140	665	350	24	235	1310	1280	530	1340	265	490	540	140	312
125/200	9	132M	150	125	140	665	350	24	235	1310	1280	530	1340	265	490	540	140	317
125/200	11	160M	150	125	140	665	350	24	235	1310	1375	625	1340	265	490	540	140	351
125/200	15	160L	150	125	140	665	350	24	235	1310	1420	670	1340	265	490	540	140	370
125/250	7.5	132M	150	125	140	705	350	24	235	1310	1280	530	1340	265	490	540	140	314
125/250	9	132M	150	125	140	705	350	24	235	1310	1280	530	1340	265	490	540	140	319
125/250	11	160M	150	125	140	705	350	24	235	1310	1375	625	1340	265	490	540	140	353
125/250	15	160L	150	125	140	705	350	29	260	1460	1420	670	1490	290	550	610	140	419
125/250	18.5	180M	150	125	140	705	350	29	260	1460	1450	700	1490	290	550	610	140	460
125/315	15	160L	150	125	140	755	400	29	300	1660	1480	670	1670	310	600	660	140	512
125/315	18.5	180M	150	125	140	755	400	29	300	1660	1510	700	1670	310	600	660	140	553
125/315	22	180L	150	125	140	755	400	29	300	1660	1550	740	1670	310	600	660	140	579
125/315	30	200L	150	125	140	755	400	29	300	1660	1610	800	1670	310	600	660	140	632
125/315	37	225S	150	125	140	755	400	29	300	1660	1680	870	1670	310	600	660	140	758
125/400	30	200L	150	125	140	835	435	29	300	1660	1610	800	1670	310	600	660	140	671
125/400	37	225S	150	125	140	835	435	29	300	1660	1680	870	1670	310	600	660	140	797
125/400	45	225M	150	125	140	835	435	29	300	1660	1680	870	1670	310	600	660	140	830
125/400	55	250M	150	125	140	835	435	29	300	1660	1760	950	1670	310	600	660	140	916
125/400	75	280S	150	125	140	835	435	29	330	1860	1870	1060	1870	340	670	730	140	1306
150/200	7.5	132M	200	150	160	800	400	29	330	1860	1300	530	1890	360	670	730	140	520
150/200	9	132M	200	150	160	800	400	29	330	1860	1300	530	1890	360	670	730	140	525
150/200	11	160M	200	150	160	800	400	29	330	1860	1395	625	1890	360	670	730	140	558
150/200	15	160L	200	150	160	800	400	29	330	1860	1440	670	1890	360	670	730	140	578
150/200	18.5	180M	200	150	160	800	400	29	330	1860	1470	700	1890	360	670	730	140	619
150/250	15	160L	200	150	160	800	400	29	300	1660	1440	670	1690	330	600	660	140	487
150/250	18.5	180M	200	150	160	800	400	29	300	1660	1470	700	1690	330	600	660	140	528
150/250	22	180L	200	150	160	800	400	29	300	1660	1510	740	1690	330	600	660	140	555

Norm pumps

Single pumps (heating, air-conditioning, cooling and industry)



Dimensions, weights Wilo-CronoNorm-NL (with spacer coupling)

Motor data (1450 rpm; with spacer coupling)

	Nominal motor power	Motor size	Nominal diameter		Dimensions													Weight approx.
	P ₂	–	DN ₁	DN ₂	A ₂	H ₄	H ₃	S ₄	L ₂	L ₁	L	L ₃	L ₄	S ₁	B ₃	B ₂	X	M
	[W]	[MG]	[mm]															
150/250	30	200L	200	150	160	800	400	29	300	1660	1570	800	1690	330	600	660	140	608
150/315	22	180L	200	150	160	800	400	29	330	1860	1510	740	1890	360	670	730	140	695
150/315	30	200L	200	150	160	800	400	29	330	1860	1570	800	1890	360	670	730	140	747
150/315	37	225S	200	150	160	800	400	29	330	1860	1640	870	1890	360	670	730	140	873
150/315	45	225M	200	150	160	800	400	29	330	1860	1640	870	1890	360	670	730	140	907
150/315	55	250M	200	150	160	800	400	29	330	1860	1720	950	1890	360	670	730	140	992
150/400	45	225M	200	150	160	885	435	29	330	1860	1640	870	1890	360	670	730	140	944
150/400	55	250M	200	150	160	885	435	29	330	1860	1720	950	1890	360	670	730	140	1029
150/400	75	280S	200	150	160	885	435	29	330	1860	1830	1060	1890	360	670	730	140	1324
150/400	90	280M	200	150	160	885	435	29	330	1860	1830	1060	1890	360	670	730	140	1394

Motor data (2900 rpm; with spacer coupling)

	Nominal motor power	Motor size	Nominal diameter		Dimensions													Weight approx.
	P ₂	–	DN ₁	DN ₂	A ₂	H ₄	H ₃	S ₄	L ₂	L ₁	L	L ₃	L ₄	S ₁	B ₃	B ₂	X	M
	[W]	[MG]	[mm]															
32/125	0.55	71	50	32	80	332	192	19	150	840	800	260	845	155	320	360	100	89
32/125	0.75	80	50	32	80	332	192	19	150	840	835	295	845	155	320	360	100	92
32/125	1.1	80	50	32	80	332	192	19	150	840	835	295	845	155	320	360	100	93
32/125	1.5	90S	50	32	80	332	192	19	150	840	885	345	845	155	320	360	100	98
32/125	2.2	90L	50	32	80	332	192	19	170	940	885	345	945	175	350	390	100	101
32/160	1.5	90S	50	32	80	372	212	19	150	840	885	345	845	155	320	360	100	101
32/160	2.2	90L	50	32	80	372	212	19	170	940	885	345	945	175	350	390	100	103
32/160	3	100L	50	32	80	372	212	19	170	940	920	380	945	175	350	390	100	123
32/160	4	112M	50	32	80	372	212	19	170	940	1000	460	945	175	350	390	100	134
32/160	5.5	132S	50	32	80	372	212	19	170	940	1055	515	945	175	350	390	100	154
32/160B	1.5	90S	50	32	80	372	212	19	150	840	885	345	845	155	320	360	100	101
32/160B	2.2	90L	50	32	80	372	212	19	170	940	885	345	945	175	350	390	100	113
32/160B	3	100L	50	32	80	372	212	19	170	940	920	380	945	175	350	390	100	123
32/160B	4	112M	50	32	80	372	212	19	170	940	1000	460	945	175	350	390	100	134
32/160B	5.5	132S	50	32	80	372	212	19	170	940	1055	515	945	175	350	390	100	154
32/200	2.2	90L	50	32	80	420	240	19	170	940	885	345	945	175	350	390	100	104
32/200	3	100L	50	32	80	420	240	19	170	940	920	380	945	175	350	390	100	124
32/200	4	112M	50	32	80	420	240	19	170	940	1000	460	945	175	350	390	100	135
32/200	5.5	132S	50	32	80	420	240	19	170	940	1055	515	945	175	350	390	100	156
32/200	7.5	132S	50	32	80	420	240	19	170	940	1055	515	945	175	350	390	100	162
32/200	9	132M	50	32	80	420	240	19	170	940	1070	530	945	175	350	390	100	168
32/200	11	160M	50	32	80	440	260	24	190	1040	1165	625	1045	195	400	450	100	214
32/200B	2.2	90L	50	32	80	420	240	19	170	940	885	345	945	175	350	390	100	114
32/200B	3	100L	50	32	80	420	240	19	170	940	920	380	945	175	350	390	100	124
32/200B	4	112M	50	32	80	420	240	19	170	940	1000	460	945	175	350	390	100	135

Norm pumps

Single pumps (heating, air-conditioning, cooling and industry)

Dimensions, weights Wilo-CronoNorm-NL (with spacer coupling)

Motor data (2900 rpm; with spacer coupling)

	Nominal motor power	Motor size	Nominal diameter		Dimensions													Weight approx.
	P ₂	–	DN ₁	DN ₂	A ₂	H ₄	H ₃	S ₄	L ₂	L ₁	L	L ₃	L ₄	S1	B3	B2	X	M
	[W]	[MG]	[mm]															[kg]
32/200B	5.5	132S	50	32	80	420	240	19	170	940	1055	515	945	175	350	390	100	156
32/200B	7.5	132S	50	32	80	420	240	19	170	940	1055	515	945	175	350	390	100	162
32/200B	9	132M	50	32	80	420	240	19	170	940	1070	530	945	175	350	390	100	168
32/200B	11	160M	50	32	80	440	260	24	190	1040	1165	625	1045	195	400	450	100	214
32/250	7.5	132S	50	32	100	505	280	24	190	1040	1075	515	1050	200	400	450	100	187
32/250	9	132M	50	32	100	505	280	24	190	1040	1090	530	1050	200	400	450	100	193
32/250	11	160M	50	32	100	505	280	24	190	1040	1185	625	1050	200	400	450	100	227
32/250	15	160M	50	32	100	505	280	24	190	1040	1185	625	1050	200	400	450	100	234
40/125	1.1	80	65	40	80	332	192	19	150	840	835	295	845	155	320	360	100	90
40/125	1.5	90S	65	40	80	332	192	19	150	840	885	345	845	155	320	360	100	95
40/125	2.2	90L	65	40	80	332	192	19	170	940	885	345	945	175	350	390	100	108
40/125	3	100L	65	40	80	332	192	19	170	940	920	380	945	175	350	390	100	117
40/160	2.2	90L	65	40	80	372	212	19	170	940	885	345	945	175	350	390	100	110
40/160	3	100L	65	40	80	372	212	19	170	940	920	380	945	175	350	390	100	119
40/160	4	112M	65	40	80	372	212	19	170	940	1000	460	945	175	350	390	100	131
40/160	5.5	132S	65	40	80	372	212	19	170	940	1055	515	945	175	350	390	100	152
40/160	7.5	132S	65	40	80	372	212	19	170	940	1055	515	945	175	350	390	100	158
40/160	9	132M	65	40	80	372	212	19	170	940	1070	530	945	175	350	390	100	164
40/200	5.5	132S	65	40	100	420	240	19	170	940	1075	515	965	195	350	390	100	158
40/200	7.5	132S	65	40	100	420	240	19	170	940	1075	515	965	195	350	390	100	164
40/200	9	132M	65	40	100	420	240	19	170	940	1090	530	965	195	350	390	100	170
40/200	11	160M	65	40	100	440	260	24	190	1040	1185	625	1065	215	400	450	100	216
40/200	15	160M	65	40	100	440	260	24	190	1040	1185	625	1065	215	400	450	100	224
40/200	18.5	160L	65	40	100	440	260	24	210	1160	1230	670	1185	235	440	490	100	274
40/250	7.5	132S	65	40	100	505	280	24	190	1040	1075	515	1050	200	400	450	100	187
40/250	9	132M	65	40	100	505	280	24	190	1040	1090	530	1050	200	400	450	100	193
40/250	11	160M	65	40	100	505	280	24	190	1040	1185	625	1050	200	400	450	100	227
40/250	15	160M	65	40	100	505	280	24	190	1040	1185	625	1050	200	400	450	100	234
40/250	18.5	160L	65	40	100	505	280	24	210	1160	1230	670	1170	220	440	490	100	284
40/315	15	160M	65	40	125	575	325	24	235	1310	1320	625	1340	265	490	540	100	329
40/315	18.5	160L	65	40	125	575	325	24	235	1310	1365	670	1340	265	490	540	100	344
40/315	22	180M	65	40	125	575	325	24	235	1310	1395	700	1340	265	490	540	100	395
40/315	30	200L	65	40	125	575	325	24	235	1310	1495	800	1340	265	490	540	100	468
40/315	37	200L	65	40	125	575	325	24	235	1310	1495	800	1340	265	490	540	100	483
50/125	1.5	90S	65	50	100	372	212	19	150	840	905	345	865	175	320	360	100	97
50/125	2.2	90L	65	50	100	372	212	19	170	940	905	345	965	195	350	390	100	110
50/125	3	100L	65	50	100	372	212	19	170	940	940	380	965	195	350	390	100	119
50/125	4	112M	65	50	100	372	212	19	170	940	1020	460	965	195	350	390	100	131
50/125	5.5	132S	65	50	100	372	212	19	170	940	1075	515	965	195	350	390	100	152
50/160	3	100L	65	50	100	420	240	19	170	940	940	380	965	195	350	390	100	126
50/160	4	112M	65	50	100	420	240	19	170	940	1020	460	965	195	350	390	100	138
50/160	5.5	132S	65	50	100	420	240	19	170	940	1075	515	965	195	350	390	100	158
50/160	7.5	132S	65	50	100	420	240	19	170	940	1075	515	965	195	350	390	100	164

Norm pumps

Single pumps (heating, air-conditioning, cooling and industry)



Dimensions, weights Wilo-CronoNorm-NL (with spacer coupling)

Motor data (2900 rpm; with spacer coupling)

	Nominal motor power	Motor size	Nominal diameter		Dimensions													Weight approx.
	P ₂	–	DN ₁	DN ₂	A ₂	H ₄	H ₃	S ₄	L ₂	L ₁	L	L ₃	L ₄	S1	B3	B2	X	M
	[W]	[MG]	[mm]															[kg]
50/160	9	132M	65	50	100	420	240	19	170	940	1090	530	965	195	350	390	100	170
50/160	11	160M	65	50	100	440	260	24	190	1040	1185	625	1065	215	400	450	100	216
50/160	15	160M	65	50	100	440	260	24	190	1040	1185	625	1065	215	400	450	100	224
50/200	7.5	132S	65	50	100	440	240	19	170	940	1075	515	965	195	350	390	100	168
50/200	9	132M	65	50	100	440	240	19	170	940	1090	530	965	195	350	390	100	174
50/200	11	160M	65	50	100	460	260	24	190	1040	1185	625	1065	215	400	450	100	220
50/200	15	160M	65	50	100	460	260	24	190	1040	1185	625	1065	215	400	450	100	228
50/200	18.5	160L	65	50	100	460	260	24	210	1160	1230	670	1185	235	440	490	100	278
50/200	22	180M	65	50	100	480	280	24	210	1160	1260	700	1185	235	440	490	100	329
50/250	11	160M	65	50	100	505	280	24	190	1040	1185	625	1050	200	400	450	100	231
50/250	15	160M	65	50	100	505	280	24	190	1040	1185	625	1050	200	400	450	100	238
50/250	18.5	160L	65	50	100	505	280	24	210	1160	1230	670	1170	220	440	490	100	289
50/250	22	180M	65	50	100	505	280	24	210	1160	1260	700	1170	220	440	490	100	339
50/250	30	200L	65	50	100	525	300	24	235	1310	1360	800	1315	240	490	540	100	444
50/315	15	160M	65	50	125	605	325	24	235	1310	1320	625	1340	265	490	540	100	344
50/315	18.5	160L	65	50	125	605	325	24	235	1310	1365	670	1340	265	490	540	100	360
50/315	22	180M	65	50	125	605	325	24	235	1310	1395	700	1340	265	490	540	100	411
50/315	30	200L	65	50	125	605	325	24	235	1310	1495	800	1340	265	490	540	100	484
50/315	37	200L	65	50	125	605	325	24	235	1310	1495	800	1340	265	490	540	100	498
50/315	45	225S-M	65	50	125	605	325	29	260	1460	1535	840	1490	290	550	610	100	712
50/315	55	250S-M	65	50	125	630	350	29	260	1460	1645	950	1490	290	550	610	100	798
50/315	75	280S-M	65	50	125	680	400	29	330	1860	1755	1060	1890	360	670	730	100	1111
65/125	3	100L	80	65	100	420	240	19	170	940	940	380	965	195	350	390	100	123
65/125	4	112M	80	65	100	420	240	19	170	940	1020	460	965	195	350	390	100	134
65/125	5.5	132S	80	65	100	420	240	19	170	940	1075	515	965	195	350	390	100	155
65/125	7.5	132S	80	65	100	420	240	19	170	940	1075	515	965	195	350	390	100	161
65/125	9	132M	80	65	100	420	240	19	170	940	1090	530	965	195	350	390	100	167
65/160	5.5	132S	80	65	100	440	240	19	170	940	1075	515	965	195	350	390	100	161
65/160	7.5	132S	80	65	100	440	240	19	170	940	1075	515	965	195	350	390	100	167
65/160	9	132M	80	65	100	440	240	19	170	940	1090	530	965	195	350	390	100	173
65/160	11	160M	80	65	100	460	260	24	190	1040	1185	625	1065	215	400	450	100	219
65/160	15	160M	80	65	100	460	260	24	190	1040	1185	625	1065	215	400	450	100	227
65/160	18.5	160L	80	65	100	460	260	24	210	1160	1230	670	1185	235	440	490	100	277
65/200	9	132M	80	65	100	505	280	24	190	1040	1090	530	1050	200	400	450	100	192
65/200	11	160M	80	65	100	505	280	24	210	1160	1185	625	1170	220	440	490	100	260
65/200	15	160M	80	65	100	505	280	24	210	1160	1185	625	1170	220	440	490	100	268
65/200	18.5	160L	80	65	100	505	280	24	210	1160	1230	670	1170	220	440	490	100	283
65/200	22	180M	80	65	100	505	280	24	210	1160	1260	700	1170	220	440	490	100	334
65/200	30	200L	80	65	100	525	300	24	235	1310	1360	800	1315	240	490	540	100	439
65/250	18.5	160L	80	65	100	550	300	24	235	1310	1340	670	1300	225	490	540	100	341
65/250	22	180M	80	65	100	550	300	24	235	1310	1370	700	1300	225	490	540	100	392
65/250	30	200L	80	65	100	550	300	29	260	1460	1470	800	1450	250	550	610	100	512
65/250	37	200L	80	65	100	550	300	29	260	1460	1470	800	1450	250	550	610	100	527

Norm pumps

Single pumps (heating, air-conditioning, cooling and industry)

Dimensions, weights Wilo-CronoNorm-NL (with spacer coupling)

Motor data (2900 rpm; with spacer coupling)

	Nominal motor power	Motor size	Nominal diameter		Dimensions													Weight approx.
	P ₂	–	DN ₁	DN ₂	A ₂	H ₄	H ₃	S ₄	L ₂	L ₁	L	L ₃	L ₄	S1	B3	B2	X	M
	[W]	[MG]	[mm]															[kg]
65/250	45	225S-M	80	65	100	575	325	29	260	1460	1510	840	1450	250	550	610	100	693
80/160	7.5	132S	100	80	125	505	280	24	190	1040	1140	515	1075	225	400	450	140	184
80/160	9	132M	100	80	125	505	280	24	190	1040	1155	530	1075	225	400	450	140	190
80/160	11	160M	100	80	125	505	280	24	210	1160	1250	625	1195	245	440	490	140	258
80/160	15	160M	100	80	125	505	280	24	210	1160	1250	625	1195	245	440	490	140	266
80/160	18.5	160L	100	80	125	505	280	24	210	1160	1295	670	1195	245	440	490	140	281
80/160	22	180M	100	80	125	505	280	24	210	1160	1325	700	1195	245	440	490	140	332
80/160	30	200L	100	80	125	525	300	24	235	1310	1425	800	1340	265	490	540	140	436
80/200	15	160M	100	80	125	530	280	24	235	1310	1360	625	1340	265	490	540	140	315
80/200	18.5	160L	100	80	125	530	280	24	235	1310	1405	670	1340	265	490	540	140	331
80/200	22	180M	100	80	125	530	280	24	235	1310	1435	700	1340	265	490	540	140	381
80/200	30	200L	100	80	125	550	300	24	235	1310	1535	800	1340	265	490	540	140	454
80/200	37	200L	100	80	125	550	300	24	235	1310	1535	800	1340	265	490	540	140	469
80/200	45	225S-M	100	80	125	575	325	29	260	1460	1575	840	1490	290	550	610	140	682
80/250	22	180M	100	80	125	580	300	24	235	1310	1435	700	1325	250	490	540	140	397
80/250	30	200L	100	80	125	580	300	29	260	1460	1535	800	1475	275	550	610	140	517
80/250	37	200L	100	80	125	580	300	29	260	1460	1535	800	1475	275	550	610	140	532
80/250	45	225S-M	100	80	125	605	325	29	260	1460	1575	840	1475	275	550	610	140	698
80/250	55	250S-M	100	80	125	630	350	29	260	1460	1685	950	1475	275	550	610	140	784
100/160	18.5	160L	125	100	125	580	300	24	235	1310	1405	670	1325	250	490	540	140	350
100/160	22	180M	125	100	125	580	300	24	235	1310	1435	700	1325	250	490	540	140	400
100/160	30	200L	125	100	125	580	300	29	260	1460	1535	800	1475	275	550	610	140	520
100/160	37	200L	125	100	125	580	300	29	260	1460	1535	800	1475	275	550	610	140	535
100/200	18.5	160L	125	100	125	580	300	24	235	1310	1405	670	1325	250	490	540	140	341
100/200	22	180M	125	100	125	580	300	24	235	1310	1435	700	1325	250	490	540	140	392
100/200	30	200L	125	100	125	580	300	29	260	1460	1535	800	1475	275	550	610	140	512
100/200	37	200L	125	100	125	580	300	29	260	1460	1535	800	1475	275	550	610	140	527
100/200	45	225S-M	125	100	125	605	325	29	260	1460	1575	840	1475	275	550	610	140	693
100/250	30	200L	125	100	140	605	325	29	260	1460	1550	800	1490	290	550	610	140	528
100/250	37	200L	125	100	140	605	325	29	260	1460	1550	800	1490	290	550	610	140	543
100/250	45	225S-M	125	100	140	605	325	29	260	1460	1590	840	1490	290	550	610	140	708
100/250	55	250S-M	125	100	140	630	350	29	260	1460	1700	950	1490	290	550	610	140	795
100/250	75	280S-M	125	100	140	680	400	29	330	1860	1810	1060	1890	360	670	730	140	1108
100/250	90	280S-M	125	100	140	680	400	29	330	1860	1810	1060	1890	360	670	730	140	1160
125/200	55	250S-M	150	125	140	665	350	29	260	1460	1700	950	1490	290	550	610	140	810
125/200	75	280S-M	150	125	140	715	400	29	330	1860	1810	1060	1890	360	670	730	140	1124
125/200	90	280S-M	150	125	140	715	400	29	330	1860	1810	1060	1890	360	670	730	140	1278
125/200	110	315S-M	150	125	140	753	430	29	330	1860	2100	1350	1890	360	670	730	140	1300

Norm pumps

Single pumps (heating, air-conditioning, cooling and industry)



Dimensions, weights Wilo-CronoNorm-NL (without spacer coupling)

Dimension drawing:

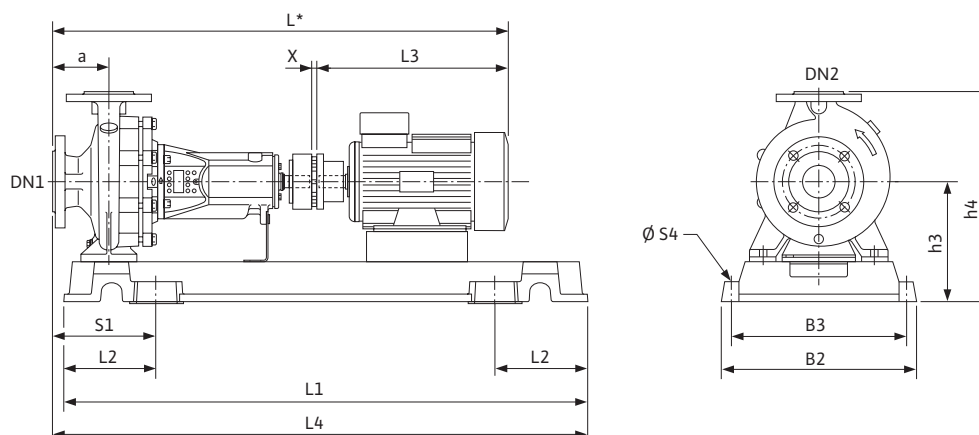

The length and width of the base block should be approx. 15 to 20 cm greater than the outer dimensions of the pump baseplate. Dimensions L*, L3: approximate dimension, since this depends on the make of the motor.

Motor data (1450 rpm; without spacer coupling)

	Nominal motor power	Motor size	Nominal diameter		Dimensions													Weight approx.
	P ₂	—	DN ₁	DN ₂	A ₂	H ₄	H ₃	S ₄	L ₂	L ₁	L	L ₃	L ₄	S1	B3	B2	X	M
	[W]	[MG]	[mm]															
32/125	0.37	71	50	32	80	332	192	19	150	840	703	260	845	155	320	360	3	88
32/160	0.37	71	50	32	80	372	212	19	150	840	703	260	845	155	320	360	3	90
32/160	0.55	80	50	32	80	372	212	19	150	840	738	295	845	155	320	360	3	93
32/160	0.75	80	50	32	80	372	212	19	150	840	738	295	845	155	320	360	3	94
32/160B	0.37	71	50	32	80	372	212	19	150	840	703	260	845	155	320	360	3	90
32/160B	0.55	80	50	32	80	372	212	19	150	840	738	295	845	155	320	360	3	93
32/160B	0.75	80	50	32	80	372	212	19	150	840	738	295	845	155	320	360	3	94
32/200	0.55	80	50	32	80	420	240	19	150	840	738	295	845	155	320	360	3	94
32/200	0.75	80	50	32	80	420	240	19	150	840	738	295	845	155	320	360	3	95
32/200	1.1	90S	50	32	80	420	240	19	150	840	788	345	845	155	320	360	3	100
32/200	1.5	90L	50	32	80	420	240	19	150	840	788	345	845	155	320	360	3	103
32/200B	0.55	80	50	32	80	420	240	19	150	840	738	295	845	155	320	360	3	94
32/200B	0.75	80	50	32	80	420	240	19	150	840	738	295	845	155	320	360	3	95
32/200B	1.1	90S	50	32	80	420	240	19	150	840	788	345	845	155	320	360	3	100
32/200B	1.5	90L	50	32	80	420	240	19	150	840	788	345	845	155	320	360	3	103
32/250	0.75	80	50	32	100	505	280	24	190	1040	758	295	1050	200	400	450	3	131
32/250	1.1	90S	50	32	100	505	280	24	190	1040	808	345	1050	200	400	450	3	135
32/250	1.5	90L	50	32	100	505	280	24	190	1040	808	345	1050	200	400	450	3	139
32/250	2.2	100L	50	32	100	505	280	24	190	1040	843	380	1050	200	400	450	3	148
40/125	0.37	71	65	40	80	332	192	19	150	840	703	260	845	155	320	360	3	85
40/125	0.55	80	65	40	80	332	192	19	150	840	738	295	845	155	320	360	3	88
40/160	0.37	71	65	40	80	372	212	19	150	840	703	260	845	155	320	360	3	87
40/160	0.55	80	65	40	80	372	212	19	150	840	738	295	845	155	320	360	3	90
40/160	0.75	80	65	40	80	372	212	19	150	840	738	295	845	155	320	360	3	91
40/160	1.1	90S	65	40	80	372	212	19	150	840	788	345	845	155	320	360	3	96

Norm pumps

Single pumps (heating, air-conditioning, cooling and industry)

Dimensions, weights Wilo-CronoNorm-NL (without spacer coupling)

Motor data (1450 rpm; without spacer coupling)

	Nominal motor power	Motor size	Nominal diameter		Dimensions													Weight approx.
	P ₂	–	DN ₁	DN ₂	A ₂	H ₄	H ₃	S ₄	L ₂	L ₁	L	L ₃	L ₄	S1	B3	B2	X	M
	[W]	[MG]	[mm]															[kg]
40/160	1.5	90L	65	40	80	372	212	19	150	840	788	345	845	155	320	360	3	99
40/200	0.55	80	65	40	100	420	240	19	170	940	758	295	965	195	350	390	3	107
40/200	0.75	80	65	40	100	420	240	19	170	940	758	295	965	195	350	390	3	108
40/200	1.1	90S	65	40	100	420	240	19	170	940	808	345	965	195	350	390	3	112
40/200	1.5	90L	65	40	100	420	240	19	170	940	808	345	965	195	350	390	3	116
40/200	2.2	100L	65	40	100	420	240	19	170	940	843	380	965	195	350	390	3	124
40/250	1.1	90S	65	40	100	505	280	24	190	1040	808	345	1050	200	400	450	3	135
40/250	1.5	90L	65	40	100	505	280	24	190	1040	808	345	1050	200	400	450	3	139
40/250	2.2	100L	65	40	100	505	280	24	190	1040	843	380	1050	200	400	450	3	148
40/250	3	100L	65	40	100	505	280	24	190	1040	843	380	1050	200	400	450	3	151
40/315	2.2	100L	65	40	125	575	325	24	210	1160	978	380	1195	245	440	490	3	211
40/315	3	100L	65	40	125	575	325	24	210	1160	978	380	1195	245	440	490	3	214
40/315	4	112M	65	40	125	575	325	24	210	1160	1058	460	1195	245	440	490	3	226
40/315	5.5	123S	65	40	125	575	325	24	210	1160	1113	515	1195	245	440	490	3	242
50/125	0.37	71	65	50	100	372	212	19	150	840	723	260	865	175	320	360	3	87
50/125	0.55	80	65	50	100	372	212	19	150	840	758	295	865	175	320	360	3	90
50/125	0.75	80	65	50	100	372	212	19	150	840	758	295	865	175	320	360	3	91
50/160	0.55	80	65	50	100	420	240	19	170	940	758	295	965	195	350	390	3	107
50/160	0.75	80	65	50	100	420	240	19	170	940	758	295	965	195	350	390	3	108
50/160	1.1	90S	65	50	100	420	240	19	170	940	808	345	965	195	350	390	3	112
50/160	1.5	90L	65	50	100	420	240	19	170	940	808	345	965	195	350	390	3	116
50/160	2.2	100L	65	50	100	420	240	19	170	940	843	380	965	195	350	390	3	124
50/200	1.1	90S	65	50	100	440	240	19	170	940	808	345	965	195	350	390	3	117
50/200	1.5	90L	65	50	100	440	240	19	170	940	808	345	965	195	350	390	3	120
50/200	2.2	100L	65	50	100	440	240	19	170	940	843	380	965	195	350	390	3	129
50/200	3	100L	65	50	100	440	240	19	170	940	843	380	965	195	350	390	3	132
50/250	1.5	90L	65	50	100	505	280	24	190	1040	808	345	1050	200	400	450	3	143
50/250	2.2	100L	65	50	100	505	280	24	190	1040	843	380	1050	200	400	450	3	152
50/250	3	100L	65	50	100	505	280	24	190	1040	843	380	1050	200	400	450	3	155
50/250	4	112M	65	50	100	505	280	24	190	1040	923	460	1050	200	400	450	3	167
50/315	4	112M	65	50	125	605	325	24	210	1160	1058	460	1195	245	440	490	3	242
50/315	5.5	123S	65	50	125	605	325	24	210	1160	1113	515	1195	245	440	490	3	258
50/315	7.5	132M	65	50	125	605	325	24	210	1160	1128	530	1195	245	440	490	3	266
50/315	9	132M	65	50	125	605	325	24	210	1160	1128	530	1195	245	440	490	3	272
65/125	0.55	80	80	65	100	420	240	19	170	940	758	295	965	195	350	390	3	103
65/125	0.75	80	80	65	100	420	240	19	170	940	758	295	965	195	350	390	3	105
65/125	1.1	90S	80	65	100	420	240	19	170	940	808	345	965	195	350	390	3	109
65/160	0.75	80	80	65	100	440	240	19	170	940	758	295	965	195	350	390	3	111
65/160	1.5	90L	80	65	100	440	240	19	170	940	808	345	965	195	350	390	3	119
65/160	2.2	100L	80	65	100	440	240	19	170	940	843	380	965	195	350	390	3	128
65/200	1.1	90S	80	65	100	505	280	24	190	1040	808	345	1050	200	400	450	3	134
65/200	1.5	90L	80	65	100	505	280	24	190	1040	808	345	1050	200	400	450	3	138
65/200	2.2	100L	80	65	100	505	280	24	190	1040	843	380	1050	200	400	450	3	146

Norm pumps

Single pumps (heating, air-conditioning, cooling and industry)



Dimensions, weights Wilo-CronoNorm-NL (without spacer coupling)

Motor data (1450 rpm; without spacer coupling)

	Nominal motor power	Motor size	Nominal diameter		Dimensions													Weight approx.
	P ₂	–	DN ₁	DN ₂	A ₂	H ₄	H ₃	S ₄	L ₂	L ₁	L	L ₃	L ₄	S1	B3	B2	X	M
	[W]	[MG]	[mm]															[kg]
65/200	3	100L	80	65	100	505	280	24	190	1040	843	380	1050	200	400	450	3	150
65/200	4	112M	80	65	100	505	280	24	190	1040	923	460	1050	200	400	450	3	162
65/250	2.2	100L	80	65	100	550	300	24	210	1160	953	380	1155	205	440	490	3	207
65/250	3	100L	80	65	100	550	300	24	210	1160	953	380	1155	205	440	490	3	211
65/250	4	112M	80	65	100	550	300	24	210	1160	1033	460	1155	205	440	490	3	223
65/250	5.5	123S	80	65	100	550	300	24	210	1160	1088	515	1155	205	440	490	3	239
65/315	5.5	123S	80	65	125	605	325	24	235	1310	1113	515	1325	250	490	540	3	294
65/315	7.5	132M	80	65	125	605	325	24	235	1310	1128	530	1325	250	490	540	3	302
65/315	9	132M	80	65	125	605	325	24	235	1310	1128	530	1325	250	490	540	3	307
65/315	11	160M	80	65	125	605	325	24	235	1310	1223	625	1325	250	490	540	3	341
65/315	15	160L	80	65	125	605	325	24	235	1310	1268	670	1325	250	490	540	3	359
80/160	1.1	90S	100	80	125	505	280	24	190	1040	833	345	1075	225	400	450	3	132
80/160	1.5	90L	100	80	125	505	280	24	190	1040	833	345	1075	225	400	450	3	136
80/160	2.2	100L	100	80	125	505	280	24	190	1040	868	380	1075	225	400	450	3	144
80/160	3	100L	100	80	125	505	280	24	190	1040	868	380	1075	225	400	450	3	148
80/160	4	112M	100	80	125	505	280	24	190	1040	948	460	1075	225	400	450	3	160
80/200	1.5	90L	100	80	125	530	280	24	210	1160	943	345	1195	245	440	490	3	188
80/200	2.2	100L	100	80	125	530	280	24	210	1160	978	380	1195	245	440	490	3	197
80/200	3	100L	100	80	125	530	280	24	210	1160	978	380	1195	245	440	490	3	200
80/200	4	112M	100	80	125	530	280	24	210	1160	1058	460	1195	245	440	490	3	213
80/200	5.5	123S	100	80	125	530	280	24	210	1160	1113	515	1195	245	440	490	3	228
80/250	3	100L	100	80	125	580	300	24	235	1310	978	380	1325	250	490	540	3	247
80/250	4	112M	100	80	125	580	300	24	235	1310	1058	460	1325	250	490	540	3	260
80/250	5.5	123S	100	80	125	580	300	24	235	1310	1113	515	1325	250	490	540	3	276
80/250	7.5	132M	100	80	125	580	300	24	235	1310	1128	530	1325	250	490	540	3	284
80/315	5.5	123S	100	80	125	665	350	24	235	1310	1113	515	1325	250	490	540	3	297
80/315	7.5	132M	100	80	125	665	350	24	235	1310	1128	530	1325	250	490	540	3	305
80/315	9	132M	100	80	125	665	350	24	235	1310	1128	530	1325	250	490	540	3	310
80/315	11	160M	100	80	125	665	350	24	235	1310	1223	625	1325	250	490	540	3	344
80/315	15	160L	100	80	125	665	350	24	235	1310	1268	670	1325	250	490	540	3	362
80/400	11	160M	125	80	125	735	380	29	260	1460	1283	625	1475	275	550	610	3	442
80/400	15	160L	125	80	125	735	380	29	260	1460	1328	670	1475	275	550	610	3	460
80/400	18.5	180M	125	80	125	735	380	29	260	1460	1358	700	1475	275	550	610	3	501
80/400	22	180L	125	80	125	735	380	29	260	1460	1398	740	1475	275	550	610	3	527
80/400	30	200L	125	80	125	735	380	29	260	1460	1458	800	1475	275	550	610	3	580
100/160	2.2	100L	125	100	125	580	300	24	210	1160	978	380	1180	230	440	490	3	216
100/160	3	100L	125	100	125	580	300	24	210	1160	978	380	1180	230	440	490	3	219
100/160	4	112M	125	100	125	580	300	24	210	1160	1058	460	1180	230	440	490	3	232
100/160	5.5	123S	125	100	125	580	300	24	210	1160	1113	515	1180	230	440	490	3	247
100/200	2.2	100L	125	100	125	580	300	24	210	1160	978	380	1180	230	440	490	3	207
100/200	3	100L	125	100	125	580	300	24	210	1160	978	380	1180	230	440	490	3	211
100/200	4	112M	125	100	125	580	300	24	210	1160	1058	460	1180	230	440	490	3	223
100/200	5.5	123S	125	100	125	580	300	24	210	1160	1113	515	1180	230	440	490	3	239

Norm pumps

Single pumps (heating, air-conditioning, cooling and industry)

Dimensions, weights Wilo-CronoNorm-NL (without spacer coupling)

Motor data (1450 rpm; without spacer coupling)

	Nominal motor power	Motor size	Nominal diameter		Dimensions													Weight approx.
	P ₂	–	DN ₁	DN ₂	A ₂	H ₄	H ₃	S ₄	L ₂	L ₁	L	L ₃	L ₄	S1	B3	B2	X	M
	[W]	[MG]	[mm]															[kg]
100/200	7.5	132M	125	100	125	580	300	24	210	1160	1128	530	1180	230	440	490	3	247
100/250	4	112M	125	100	140	605	325	24	235	1310	1073	460	1340	265	490	540	3	270
100/250	5.5	123S	125	100	140	605	325	24	235	1310	1128	515	1340	265	490	540	3	286
100/250	7.5	132M	125	100	140	605	325	24	235	1310	1143	530	1340	265	490	540	3	295
100/250	9	132M	125	100	140	605	325	24	235	1310	1143	530	1340	265	490	540	3	300
100/250	11	160M	125	100	140	605	325	24	235	1310	1238	625	1340	265	490	540	3	333
100/315	11	160M	125	100	140	665	350	24	235	1310	1238	625	1340	265	490	540	3	353
100/315	15	160L	125	100	140	665	350	24	235	1310	1283	670	1340	265	490	540	3	372
100/315	18.5	180M	125	100	140	665	350	24	235	1310	1313	700	1340	265	490	540	3	413
100/315	22	180L	125	100	140	665	350	24	235	1310	1353	740	1340	265	490	540	3	439
100/400	15	160L	125	100	140	755	400	29	300	1660	1283	670	1670	310	600	660	3	536
100/400	18.5	180M	125	100	140	755	400	29	300	1660	1313	700	1670	310	600	660	3	577
100/400	22	180L	125	100	140	755	400	29	300	1660	1353	740	1670	310	600	660	3	604
100/400	30	200L	125	100	140	755	400	29	300	1660	1413	800	1670	310	600	660	3	656
100/400	37	225S	125	100	140	755	400	29	300	1660	1483	870	1670	310	600	660	3	780
100/400	45	225M	125	100	140	755	400	29	300	1660	1483	870	1670	310	600	660	3	814
125/200	7.5	132M	150	125	140	665	350	24	235	1310	1143	530	1340	265	490	540	3	310
125/200	9	132M	150	125	140	665	350	24	235	1310	1143	530	1340	265	490	540	3	316
125/200	11	160M	150	125	140	665	350	24	235	1310	1238	625	1340	265	490	540	3	349
125/200	15	160L	150	125	140	665	350	24	235	1310	1283	670	1340	265	490	540	3	367
125/250	7.5	132M	150	125	140	705	350	24	235	1310	1143	530	1340	265	490	540	3	312
125/250	9	132M	150	125	140	705	350	24	235	1310	1143	530	1340	265	490	540	3	318
125/250	11	160M	150	125	140	705	350	24	235	1310	1238	625	1340	265	490	540	3	351
125/250	15	160L	150	125	140	705	350	24	235	1310	1283	670	1340	265	490	540	3	369
125/250	18.5	180M	150	125	140	705	350	24	235	1310	1313	700	1340	265	490	540	3	410
125/315	15	160L	150	125	140	755	400	29	300	1660	1343	670	1670	310	600	660	3	509
125/315	18.5	180M	150	125	140	755	400	29	300	1660	1373	700	1670	310	600	660	3	550
125/315	22	180L	150	125	140	755	400	29	300	1660	1413	740	1670	310	600	660	3	577
125/315	30	200L	150	125	140	755	400	29	300	1660	1473	800	1670	310	600	660	3	629
125/315	37	225S	150	125	140	755	400	29	300	1660	1543	870	1670	310	600	660	3	753
125/400	30	200L	150	125	140	835	435	29	300	1660	1473	800	1670	310	600	660	3	668
125/400	37	225S	150	125	140	835	435	29	300	1660	1543	870	1670	310	600	660	3	792
125/400	45	225M	150	125	140	835	435	29	300	1660	1543	870	1670	310	600	660	3	825
125/400	55	250M	150	125	140	835	435	29	300	1660	1623	950	1670	310	600	660	3	910
125/400	75	280S	150	125	140	835	435	29	330	1860	1733	1060	1870	340	670	730	3	1299
150/200	7.5	132M	200	150	160	800	400	29	330	1860	1163	530	1890	360	670	730	3	518
150/200	9	132M	200	150	160	800	400	29	330	1860	1163	530	1890	360	670	730	3	524
150/200	11	160M	200	150	160	800	400	29	330	1860	1258	625	1890	360	670	730	3	557
150/200	15	160L	200	150	160	800	400	29	330	1860	1303	670	1890	360	670	730	3	575
150/200	18.5	180M	200	150	160	800	400	29	330	1860	1333	700	1890	360	670	730	3	616
150/250	15	160L	200	150	160	800	400	29	300	1660	1303	670	1690	330	600	660	3	485
150/250	18.5	180M	200	150	160	800	400	29	300	1660	1333	700	1690	330	600	660	3	526
150/250	22	180L	200	150	160	800	400	29	300	1660	1373	740	1690	330	600	660	3	553

Norm pumps

Single pumps (heating, air-conditioning, cooling and industry)



Dimensions, weights Wilo-CronoNorm-NL (without spacer coupling)

Motor data (1450 rpm; without spacer coupling)

	Nominal motor power	Motor size	Nominal diameter		Dimensions													Weight approx.
	P ₂	–	DN ₁	DN ₂	A ₂	H ₄	H ₃	S ₄	L ₂	L ₁	L	L ₃	L ₄	S1	B3	B2	X	M
	[W]	[MG]	[mm]															[kg]
150/250	30	200L	200	150	160	800	400	29	300	1660	1433	800	1690	330	600	660	3	605
150/315	22	180L	200	150	160	800	400	29	330	1860	1373	740	1890	360	670	730	3	692
150/315	30	200L	200	150	160	800	400	29	330	1860	1433	800	1890	360	670	730	3	745
150/315	37	225S	200	150	160	800	400	29	330	1860	1503	870	1890	360	670	730	3	868
150/315	45	225M	200	150	160	800	400	29	330	1860	1503	870	1890	360	670	730	3	902
150/315	55	250M	200	150	160	800	400	29	330	1860	1583	950	1890	360	670	730	3	986
150/400	45	225M	200	150	160	885	435	29	330	1860	1503	870	1890	360	670	730	3	939
150/400	55	250M	200	150	160	885	435	29	330	1860	1583	950	1890	360	670	730	3	1023
150/400	75	280S	200	150	160	885	435	29	330	1860	1693	1060	1890	360	670	730	3	1317
150/400	90	280M	200	150	160	885	435	29	330	1860	1693	1060	1890	360	670	730	3	1387

Dimensions, weights Wilo-CronoNorm-NL (without spacer coupling)

	Nominal motor power	Motor size	Nominal diameter		Dimensions													Weight approx.
	P ₂	–	DN ₁	DN ₂	A ₂	H ₄	H ₃	S ₄	L ₂	L ₁	L	L ₃	L ₄	S1	B3	B2	X	M
	[W]	[MG]	[mm]															[kg]
32/125	0.55	71	50	32	80	332	192	19	150	840	703	260	845	155	320	360	3	87
32/125	0.75	80	50	32	80	332	192	19	150	840	738	295	845	155	320	360	3	91
32/125	1.1	80	50	32	80	332	192	19	150	840	738	295	845	155	320	360	3	91
32/125	1.5	90S	50	32	80	332	192	19	150	840	788	345	845	155	320	360	3	97
32/125	2.2	90L	50	32	80	332	192	19	150	840	788	345	845	155	320	360	3	99
32/160	1.5	90S	50	32	80	372	212	19	150	840	788	345	845	155	320	360	3	99
32/160	2.2	90L	50	32	80	372	212	19	150	840	788	345	845	155	320	360	3	101
32/160	3	100L	50	32	80	372	212	19	150	840	823	380	845	155	320	360	3	111
32/160	4	112M	50	32	80	372	212	19	150	840	903	460	845	155	320	360	3	122
32/160	5.5	132S	50	32	80	372	212	19	150	840	958	515	845	155	320	360	3	143
32/160B	1.5	90S	50	32	80	372	212	19	150	840	788	345	845	155	320	360	3	99
32/160B	2.2	90L	50	32	80	372	212	19	150	840	788	345	845	155	320	360	3	101
32/160B	3	100L	50	32	80	372	212	19	150	840	823	380	845	155	320	360	3	111
32/160B	4	112M	50	32	80	372	212	19	150	840	903	460	845	155	320	360	3	122
32/160B	5.5	132S	50	32	80	372	212	19	150	840	958	515	845	155	320	360	3	143
32/200	2.2	90L	50	32	80	420	240	19	150	840	788	345	845	155	320	360	3	102
32/200	3	100L	50	32	80	420	240	19	150	840	823	380	845	155	320	360	3	112
32/200	4	112M	50	32	80	420	240	19	150	840	903	460	845	155	320	360	3	123
32/200	5.5	132S	50	32	80	420	240	19	150	840	958	515	845	155	320	360	3	144
32/200	7.5	132S	50	32	80	420	240	19	150	840	958	515	845	155	320	360	3	150
32/200	9	132M	50	32	80	420	240	19	150	840	973	530	845	155	320	360	3	156
32/200	11	160M	50	32	80	440	260	24	190	1040	1068	625	1045	195	400	450	3	213
32/200B	2.2	90L	50	32	80	420	240	19	150	840	788	345	845	155	320	360	3	102
32/200B	3	100L	50	32	80	420	240	19	150	840	823	380	845	155	320	360	3	112
32/200B	4	112M	50	32	80	420	240	19	150	840	903	460	845	155	320	360	3	123

Norm pumps

Single pumps (heating, air-conditioning, cooling and industry)

Dimensions, weights Wilo-CronoNorm-NL (without spacer coupling)

Dimensions, weights Wilo-CronoNorm-NL (without spacer coupling)

	Nominal motor power	Motor size	Nominal diameter		Dimensions													Weight approx.
	P ₂	–	DN ₁	DN ₂	A ₂	H ₄	H ₃	S ₄	L ₂	L ₁	L	L ₃	L ₄	S1	B3	B2	X	M
	[W]	[MG]	[mm]															[kg]
32/200B	5.5	132S	50	32	80	420	240	19	150	840	958	515	845	155	320	360	3	144
32/200B	7.5	132S	50	32	80	420	240	19	150	840	958	515	845	155	320	360	3	150
32/200B	9	132M	50	32	80	420	240	19	150	840	973	530	845	155	320	360	3	156
32/200B	11	160M	50	32	80	440	260	24	190	1040	1068	625	1045	195	400	450	3	213
32/250	7.5	132S	50	32	100	505	280	24	190	1040	978	515	1050	200	400	450	3	186
32/250	9	132M	50	32	100	505	280	24	190	1040	993	530	1050	200	400	450	3	192
32/250	11	160M	50	32	100	505	280	24	190	1040	1088	625	1050	200	400	450	3	225
32/250	15	160M	50	32	100	505	280	24	190	1040	1088	625	1050	200	400	450	3	233
40/125	1.1	80	65	40	80	332	192	19	150	840	738	295	845	155	320	360	3	88
40/125	1.5	90S	65	40	80	332	192	19	150	840	788	345	845	155	320	360	3	94
40/125	2.2	90L	65	40	80	332	192	19	150	840	788	345	845	155	320	360	3	96
40/125	3	100L	65	40	80	332	192	19	150	840	823	380	845	155	320	360	3	106
40/160	2.2	90L	65	40	80	372	212	19	150	840	788	345	845	155	320	360	3	98
40/160	3	100L	65	40	80	372	212	19	150	840	823	380	845	155	320	360	3	108
40/160	4	112M	65	40	80	372	212	19	150	840	903	460	845	155	320	360	3	119
40/160	5.5	132S	65	40	80	372	212	19	150	840	958	515	845	155	320	360	3	140
40/160	7.5	132S	65	40	80	372	212	19	150	840	958	515	845	155	320	360	3	146
40/160	9	132M	65	40	80	372	212	19	150	840	973	530	845	155	320	360	3	152
40/200	5.5	132S	65	40	100	420	240	19	170	940	978	515	965	195	350	390	3	157
40/200	7.5	132S	65	40	100	420	240	19	170	940	978	515	965	195	350	390	3	163
40/200	9	132M	65	40	100	420	240	19	170	940	993	530	965	195	350	390	3	169
40/200	11	160M	65	40	100	440	260	24	190	1040	1088	625	1065	215	400	450	3	215
40/200	15	160M	65	40	100	440	260	24	190	1040	1088	625	1065	215	400	450	3	222
40/200	18.5	160L	65	40	100	440	260	24	190	1040	1133	670	1065	215	400	450	3	238
40/250	7.5	132S	65	40	100	505	280	24	190	1040	978	515	1050	200	400	450	3	186
40/250	9	132M	65	40	100	505	280	24	190	1040	993	530	1050	200	400	450	3	192
40/250	11	160M	65	40	100	505	280	24	190	1040	1088	625	1050	200	400	450	3	225
40/250	15	160M	65	40	100	505	280	24	190	1040	1088	625	1050	200	400	450	3	233
40/250	18.5	160L	65	40	100	505	280	24	190	1040	1133	670	1050	200	400	450	3	248
40/315	15	160M	65	40	125	575	325	24	210	1160	1223	625	1195	245	440	490	3	296
40/315	18.5	160L	65	40	125	575	325	24	210	1160	1268	670	1195	245	440	490	3	311
40/315	22	180M	65	40	125	575	325	24	210	1160	1298	700	1195	245	440	490	3	361
40/315	30	200L	65	40	125	575	325	24	235	1310	1398	800	1340	265	490	540	3	465
40/315	37	200L	65	40	125	575	325	24	235	1310	1398	800	1340	265	490	540	3	480
50/125	1.5	90S	65	50	100	372	212	19	150	840	808	345	865	175	320	360	3	96
50/125	2.2	90L	65	50	100	372	212	19	150	840	808	345	865	175	320	360	3	98
50/125	3	100L	65	50	100	372	212	19	150	840	843	380	865	175	320	360	3	108
50/125	4	112M	65	50	100	372	212	19	150	840	923	460	865	175	320	360	3	119
50/125	5.5	132S	65	50	100	372	212	19	150	840	978	515	865	175	320	360	3	140
50/160	3	100L	65	50	100	420	240	19	170	940	843	380	965	195	350	390	3	124
50/160	4	112M	65	50	100	420	240	19	170	940	923	460	965	195	350	390	3	137
50/160	5.5	132S	65	50	100	420	240	19	170	940	978	515	965	195	350	390	3	157
50/160	7.5	132S	65	50	100	420	240	19	170	940	978	515	965	195	350	390	3	163

Norm pumps

Single pumps (heating, air-conditioning, cooling and industry)



Dimensions, weights Wilo-CronoNorm-NL (without spacer coupling)

Dimensions, weights Wilo-CronoNorm-NL (without spacer coupling)

	Nominal motor power	Motor size	Nominal diameter		Dimensions													Weight approx.
	P ₂	–	DN ₁	DN ₂	A ₂	H ₄	H ₃	S ₄	L ₂	L ₁	L	L ₃	L ₄	S ₁	B ₃	B ₂	X	M
	[W]	[MG]	[mm]															
50/160	9	132M	65	50	100	420	240	19	170	940	993	530	965	195	350	390	3	169
50/160	11	160M	65	50	100	440	260	24	190	1040	1088	625	1065	215	400	450	3	215
50/160	15	160M	65	50	100	440	260	24	190	1040	1088	625	1065	215	400	450	3	222
50/200	7.5	132S	65	50	100	440	240	19	170	940	978	515	965	195	350	390	3	167
50/200	9	132M	65	50	100	440	240	19	170	940	993	530	965	195	350	390	3	173
50/200	11	160M	65	50	100	460	260	24	190	1040	1088	625	1065	215	400	450	3	219
50/200	15	160M	65	50	100	460	260	24	190	1040	1088	625	1065	215	400	450	3	226
50/200	18.5	160L	65	50	100	460	260	24	190	1040	1133	670	1065	215	400	450	3	242
50/200	22	180M	65	50	100	480	280	24	190	1040	1163	700	1065	215	400	450	3	292
50/250	11	160M	65	50	100	505	280	24	190	1040	1088	625	1050	200	400	450	3	230
50/250	15	160M	65	50	100	505	280	24	190	1040	1088	625	1050	200	400	450	3	237
50/250	18.5	160L	65	50	100	505	280	24	190	1040	1133	670	1050	200	400	450	3	253
50/250	22	180M	65	50	100	505	280	24	190	1040	1163	700	1050	200	400	450	3	302
50/250	30	200L	65	50	100	525	300	24	235	1310	1263	800	1315	240	490	540	3	441
50/315	15	160M	65	50	125	605	325	24	210	1160	1223	625	1195	245	440	490	3	311
50/315	18.5	160L	65	50	125	605	325	24	210	1160	1268	670	1195	245	440	490	3	327
50/315	22	180M	65	50	125	605	325	24	210	1160	1298	700	1195	245	440	490	3	377
50/315	30	200L	65	50	125	605	325	24	235	1310	1398	800	1340	265	490	540	3	481
50/315	37	200L	65	50	125	605	325	24	235	1310	1398	800	1340	265	490	540	3	496
50/315	45	225S-M	65	50	125	605	325	24	235	1310	1438	840	1340	265	490	540	3	662
50/315	55	250S-M	65	50	125	630	350	29	260	1460	1548	950	1490	290	550	610	3	793
50/315	75	280S-M	65	50	125	680	400	29	330	1860	1658	1060	1890	360	670	730	3	1105
65/125	3	100L	80	65	100	420	240	19	170	940	843	380	965	195	350	390	3	121
65/125	4	112M	80	65	100	420	240	19	170	940	923	460	965	195	350	390	3	132
65/125	5.5	132S	80	65	100	420	240	19	170	940	978	515	965	195	350	390	3	153
65/125	7.5	132S	80	65	100	420	240	19	170	940	978	515	965	195	350	390	3	160
65/125	9	132M	80	65	100	420	240	19	170	940	993	530	965	195	350	390	3	165
65/160	5.5	132S	80	65	100	440	240	19	170	940	978	515	965	195	350	390	3	160
65/160	7.5	132S	80	65	100	440	240	19	170	940	978	515	965	195	350	390	3	166
65/160	9	132M	80	65	100	440	240	19	170	940	993	530	965	195	350	390	3	172
65/160	11	160M	80	65	100	460	260	24	190	1040	1088	625	1065	215	400	450	3	218
65/160	15	160M	80	65	100	460	260	24	190	1040	1088	625	1065	215	400	450	3	225
65/160	18.5	160L	80	65	100	460	260	24	190	1040	1133	670	1065	215	400	450	3	241
65/200	9	132M	80	65	100	505	280	24	190	1040	993	530	1050	200	400	450	3	191
65/200	11	160M	80	65	100	505	280	24	190	1040	1088	625	1050	200	400	450	3	224
65/200	15	160M	80	65	100	505	280	24	190	1040	1088	625	1050	200	400	450	3	232
65/200	18.5	160L	80	65	100	505	280	24	190	1040	1133	670	1050	200	400	450	3	247
65/200	22	180M	80	65	100	505	280	24	190	1040	1163	700	1050	200	400	450	3	297
65/200	30	200L	80	65	100	525	300	24	235	1310	1263	800	1315	240	490	540	3	436
65/250	18.5	160L	80	65	100	550	300	24	210	1160	1243	670	1155	205	440	490	3	308
65/250	22	180M	80	65	100	550	300	24	210	1160	1273	700	1155	205	440	490	3	358
65/250	30	200L	80	65	100	550	300	24	235	1310	1373	800	1300	225	490	540	3	462
65/250	37	200L	80	65	100	550	300	24	235	1310	1373	800	1300	225	490	540	3	477

Norm pumps

Norm pumps

Single pumps (heating, air-conditioning, cooling and industry)

Dimensions, weights Wilo-CronoNorm-NL (without spacer coupling)

Dimensions, weights Wilo-CronoNorm-NL (without spacer coupling)

	Nominal motor power	Motor size	Nominal diameter		Dimensions													Weight approx.
	P ₂	–	DN ₁	DN ₂	A ₂	H ₄	H ₃	S ₄	L ₂	L ₁	L	L ₃	L ₄	S1	B3	B2	X	M
	[W]	[MG]	[mm]															[kg]
65/250	45	225S-M	80	65	100	575	325	24	235	1310	1413	840	1300	225	490	540	3	643
80/160	7.5	132S	100	80	125	505	280	24	190	1040	1003	515	1075	225	400	450	3	183
80/160	9	132M	100	80	125	505	280	24	190	1040	1018	530	1075	225	400	450	3	189
80/160	11	160M	100	80	125	505	280	24	190	1040	1113	625	1075	225	400	450	3	222
80/160	15	160M	100	80	125	505	280	24	190	1040	1113	625	1075	225	400	450	3	230
80/160	18.5	160L	100	80	125	505	280	24	190	1040	1158	670	1075	225	400	450	3	245
80/160	22	180M	100	80	125	505	280	24	190	1040	1188	700	1075	225	400	450	3	295
80/160	30	200L	100	80	125	525	300	24	235	1310	1288	800	1340	265	490	540	3	434
80/200	15	160M	100	80	125	530	280	24	210	1160	1223	625	1195	245	440	490	3	282
80/200	18.5	160L	100	80	125	530	280	24	210	1160	1268	670	1195	245	440	490	3	298
80/200	22	180M	100	80	125	530	280	24	210	1160	1298	700	1195	245	440	490	3	347
80/200	30	200L	100	80	125	550	300	24	235	1310	1398	800	1340	265	490	540	3	452
80/200	37	200L	100	80	125	550	300	24	235	1310	1398	800	1340	265	490	540	3	466
80/200	45	225S-M	100	80	125	575	325	24	235	1310	1438	840	1340	265	490	540	3	632
80/250	22	180M	100	80	125	580	300	24	235	1310	1298	700	1325	250	490	540	3	395
80/250	30	200L	100	80	125	580	300	24	235	1310	1398	800	1325	250	490	540	3	467
80/250	37	200L	100	80	125	580	300	24	235	1310	1398	800	1325	250	490	540	3	482
80/250	45	225S-M	100	80	125	605	325	24	235	1310	1438	840	1325	250	490	540	3	648
80/250	55	250S-M	100	80	125	630	350	29	260	1460	1548	950	1475	275	550	610	3	779
100/160	18.5	160L	125	100	125	580	300	24	210	1160	1268	670	1180	230	440	490	3	317
100/160	22	180M	125	100	125	580	300	24	210	1160	1298	700	1180	230	440	490	3	366
100/160	30	200L	125	100	125	580	300	24	235	1310	1398	800	1325	250	490	540	3	471
100/160	37	200L	125	100	125	580	300	24	235	1310	1398	800	1325	250	490	540	3	485
100/200	18.5	160L	125	100	125	580	300	24	210	1160	1268	670	1180	230	440	490	3	308
100/200	22	180M	125	100	125	580	300	24	210	1160	1298	700	1180	230	440	490	3	358
100/200	30	200L	125	100	125	580	300	24	235	1310	1398	800	1325	250	490	540	3	462
100/200	37	200L	125	100	125	580	300	24	235	1310	1398	800	1325	250	490	540	3	477
100/200	45	225S-M	125	100	125	605	325	24	235	1310	1438	840	1325	250	490	540	3	643
100/250	30	200L	125	100	140	605	325	24	235	1310	1413	800	1340	265	490	540	3	478
100/250	37	200L	125	100	140	605	325	24	235	1310	1413	800	1340	265	490	540	3	493
100/250	45	225S-M	125	100	140	605	325	24	235	1310	1453	840	1340	265	490	540	3	659
100/250	55	250S-M	125	100	140	630	350	29	260	1460	1563	950	1490	290	550	610	3	789
100/250	75	280S-M	125	100	140	680	400	29	330	1860	1673	1060	1890	360	670	730	3	1102
100/250	90	280S-M	125	100	140	680	400	29	330	1860	1673	1060	1890	360	670	730	3	1154
125/200	55	250S-M	150	125	140	665	350	29	260	1460	1563	950	1490	290	550	610	3	805
125/200	75	280S-M	150	125	140	715	400	29	330	1860	1673	1060	1890	360	670	730	3	1118
125/200	90	280S-M	150	125	140	715	400	29	330	1860	1673	1060	1890	360	670	730	3	1170
125/200	110	315S-M	150	125	140	753	430	29	330	1860	1963	1350	1890	360	670	730	3	1294

Norm pumps

Single pumps (heating, air-conditioning, cooling and industry)



Flange dimensions Wilo-CronoNorm-NL

Dimension drawing:

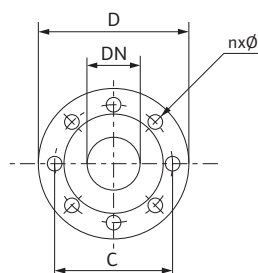

Flange dimensions (suction side)

Wilo-CronoNorm-NL ...	Nominal diameter	Pump flange dimensions			Flange
	DN ₁	∅ D ₁	∅ k ₁	n x d _{L1}	PN
		[mm]			[pcs. x mm]
32...	50	165	125	4 x 18	16
40...	65	185	145	4 x 18	16
50...	65	185	145	4 x 18	16
65...	80	200	160	4 x 18	16
80...	100	220	180	8 x 18	16
100...	125	250	210	8 x 18	16
125...	150	285	240	8 x 18	16
150...	200	340	295	8 x 22	10

Flange dimensions (pressure side)

Wilo-CronoNorm-NL ...	Nominal diameter	Pump flange dimensions			Flange
	DN ₂	∅ D ₂	∅ k ₂	n x d _{L2}	PN
		[mm]			[pcs. x mm]
32...	32	140	100	4 x 18	16
40...	40	150	110	4 x 18	16
50...	50	165	125	4 x 18	16
65...	65	185	145	4 x 18	16
80...	80	200	160	8 x 18	16
100...	100	220	180	8 x 18	16
125...	125	250	210	8 x 18	16
150...	150	285	240	8 x 22	16

Norm pumps

Wilo-VeroNorm-NPG

Series description Wilo-VeroNorm-NPG

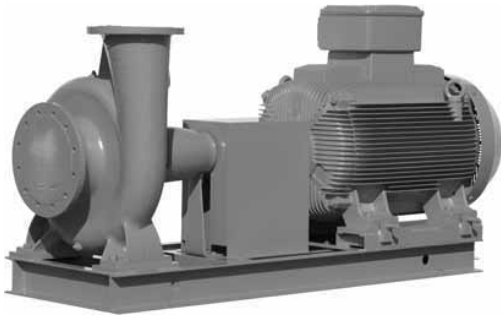

Wilo-VeroNorm-NPG

Bare shaft end, completely installed or pump without motor

Type key

Example: **Wilo-VeroNorm-NPG 150/200-55/4**

NPG	Pump with axial suction piece
150	DN for the pressure flange
200	Impeller nominal diameter
55/	Nominal motor power
4	4-pole motor

Areas of application

The pumps Wilo-VeroNorm-NPG are for pumping clean or slightly contaminated water (max. 20 ppm) without solid matter for circulation, transfer and pressure boosting purposes. For applications in municipal water supply, irrigation, building services, general industry, power stations, etc.

Construction

Single-stage, non self-priming centrifugal pump, with axial suction and radial pressure port. Connection between pump and motor by means of flexible coupling with spacer. Coupling shielded by coupling protection. Wear rings on the pump housing and housing cover as optional equipment. Sealing either through non-cooled mechanical seals or non-cooled stuffing boxes.

Obtainable versions:

- Housing (depending on the model):
grey cast iron with graphite flakes or nodular graphite
- Impeller (depending on the model):
grey cast iron with graphite flakes or bronze

Scope of delivery

- Bare shaft pumps **or**
- Pump on baseplate with coupling, spacer and coupling protection, without motor **or**
- Complete installation on baseplate with coupling, spacer, protection and electric motor.
- Including installation and operating instructions.

Pump with bare shaft end:

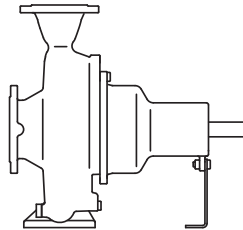

Pump on baseplate with coupling, spacer and coupling protection, without motor:

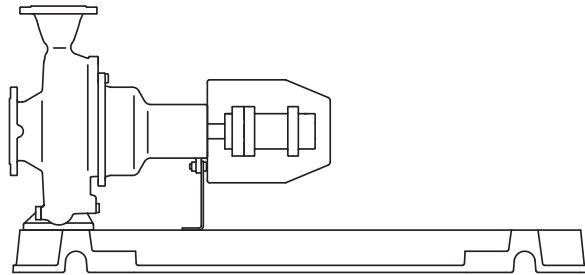

Complete installation on baseplate with coupling, spacer, coupling protection and electric motor:

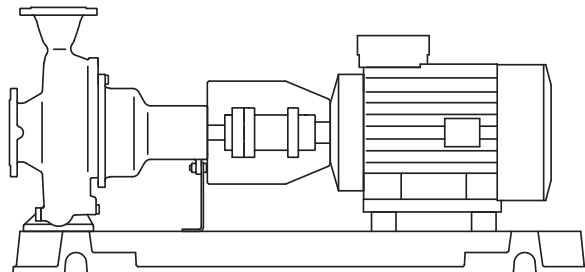

Installation design

Single-stage low-pressure centrifugal pump mounted on baseplate with axial suction piece with flanged bearing bracket and axis mounting for flexibly coupled drives.

Pump housing – VeroNorm-NPG design

Cast iron spirals with axially aligned suction piece and radial pressure ports and cast assembly feet.

Shaft seal

Stuffing box for water up to 105 °C.

Mechanical seal for water up to 140 °C (depending on the model).

Series description Wilo-VeroNorm-NPG

Construction

Wilo-VeroNorm-NPG pumps are completely installed on a baseplate and delivered with electric motor (selected make), coupling and coupling protection.

Spacer couplings are used for the purpose of simple maintenance: The pump rotor can be removed without removing the motor (also available without spacer upon request).

Accessories

Automatic rotational speed monitoring:

Wilo-Pump control system for the automatic, infinitely variable power control of pumps. For additional information, see "Switchgears and control devices" section.

Operation

- If pumps with 2900 rpm are installed inside residential buildings, then corresponding noise-reducing measures are to be implemented.
- Pump curves and specific motor powers depend on the respective fluid being pumped. Pump curves and power vary considerably when fluids are conveyed that differ from water in thickness and/or viscosity.
- Load-sensitive pump performance
- All Wilo norm pumps are equipped with IEC standard motors. The Wilo control devices are suitable for automatic load-sensitive speed control of pumps that are driven by any standard motors of conventional manufacture.
- Main/standby operation

Norm pumps

Wilo-VeroNorm-NPG

Series description Wilo-VeroNorm-NPG

Cross-section drawing: Pump with bearing B3 (version with mechanical seal)

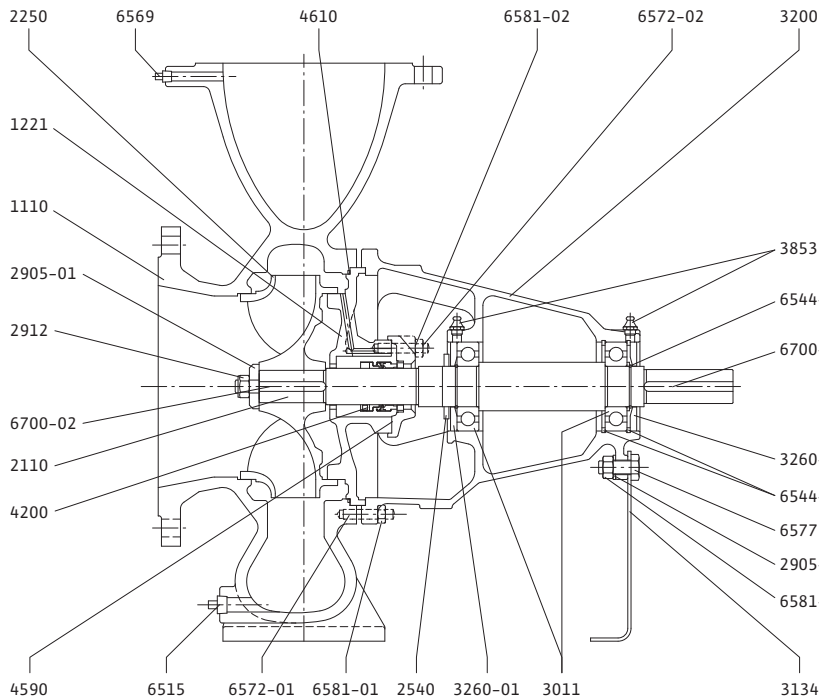

- | | |
|---------|---------------------|
| 1110 | Pump housing |
| 1221 | Housing cover |
| 2110 | Pump shaft |
| 2250 | Impeller |
| 2540 | Thrower |
| 2905-01 | Washer |
| 2905-02 | Washer |
| 2912 | Impeller nut |
| 3011 | Radial ball bearing |
| 3134 | Support foot |
| 3200 | Bearing housing |
| 3260-01 | Bearing cover |
| 3260-02 | Bearing cover |
| 3853 | Grease nipple |
| 4200 | Mechanical seal |
| 4590 | Seal |
| 4610 | O-ring |
| 6515 | Drain plug |
| 6544-01 | Circlip |
| 6544-02 | Circlip |
| 6569 | Plug |
| 6572-01 | Stud |
| 6572-02 | Stud |
| 6577 | Hexagon head bolt |
| 6581-01 | Hexagon nut |
| 6581-02 | Hexagon nut |
| 6581-03 | Hexagon nut |
| 6700-01 | Key for coupling |
| 6700-02 | Key for impeller |

Cross-sectional drawing: Pump with bearing B3 (version with stuffing box)

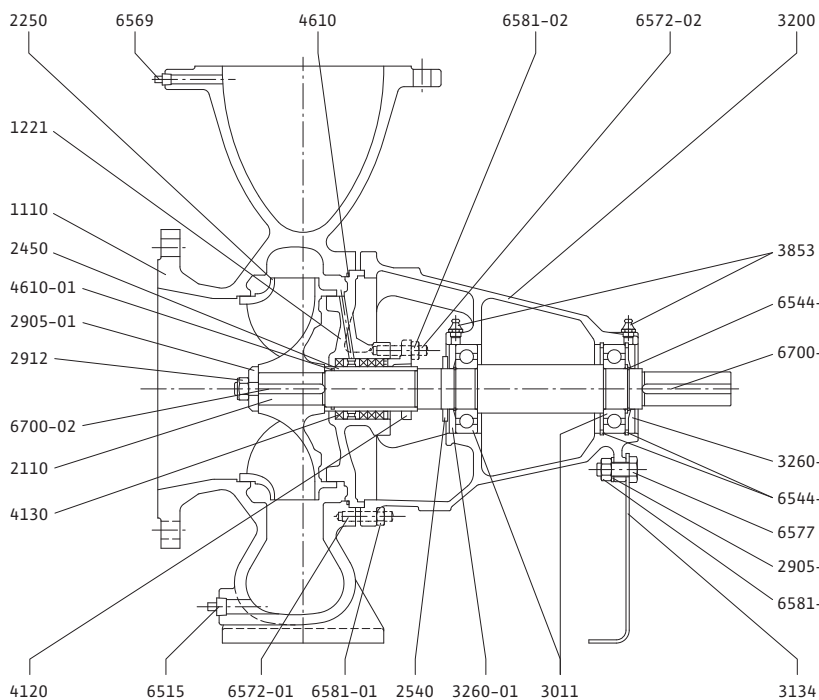

- | | |
|---------|-------------------------|
| 1110 | Pump housing |
| 1221 | Housing cover |
| 2110 | Pump shaft |
| 2250 | Impeller |
| 2450 | Shaft protection sleeve |
| 2540 | Thrower |
| 2905-01 | Washer |
| 2905-02 | Washer |
| 2912 | Impeller nut |
| 3011 | Radial ball bearing |
| 3134 | Support foot |
| 3200 | Bearing housing |
| 3260-01 | Bearing cover |
| 3260-02 | Bearing cover |
| 3853 | Grease nipple |
| 4120 | Gland |
| 4130 | Stuffing box |
| 4610 | O-ring |
| 4610-01 | O-ring |
| 6515 | Drain plug |
| 6544-01 | Circlip |
| 6544-02 | Circlip |
| 6569 | Plug |
| 6572-01 | Stud |
| 6572-02 | Stud |
| 6577 | Hexagon head bolt |
| 6581-01 | Hexagon nut |
| 6581-02 | Hexagon nut |
| 6581-03 | Hexagon nut |
| 6700-01 | Key for coupling |
| 6700-02 | Key for impeller |

Norm pumps

Wilo-VeroNorm-NPG



Series description Wilo-VeroNorm-NPG

Cross-sectional drawing: Pump with bearings B21 and B40

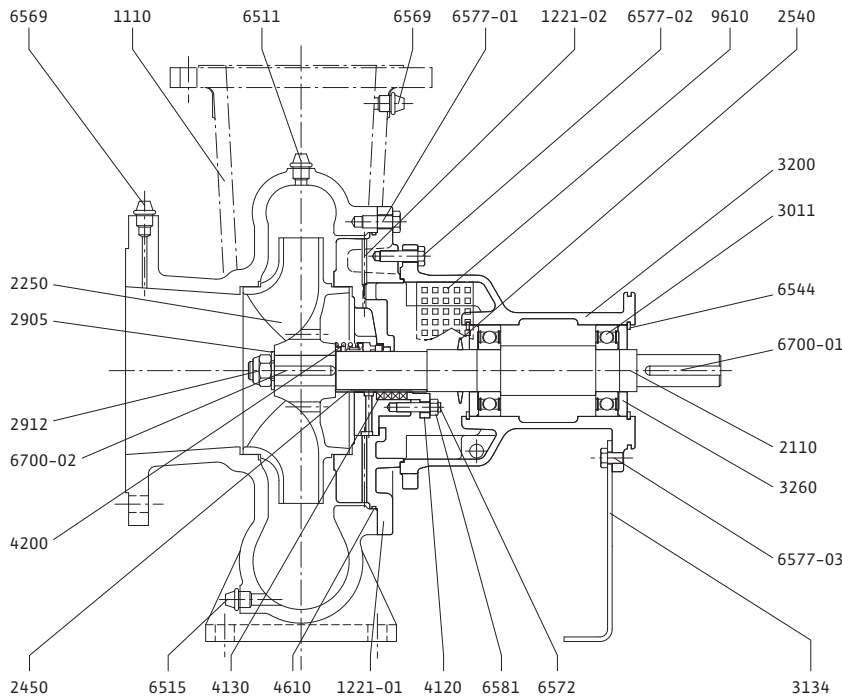

- 1110 Pump housing
- 1221-01 Housing cover
- 1221-02 Housing cover
- 2110 Pump shaft
- 2250 Impeller
- 2450 Shaft protection sleeve
- 2540 Thrower
- 2905 Washer
- 2912 Impeller nut
- 3011 Radial ball bearing
- 3134 Support foot
- 3200 Bearing housing
- 3260 Bearing cover
- 4120 Gland
- 4130 Stuffing box
- 4200 Mechanical seal
- 4610 O-ring
- 6511 Filling screw
- 6515 Drain plug
- 6544 Circlip
- 6569 Plug
- 6572 Stud
- 6577-01 Hexagon head bolt
- 6577-02 Hexagon head bolt
- 6577-03 Hexagon head bolt
- 6581 Hexagon nut
- 6700-01 Key for coupling
- 6700-02 Key for impeller
- 9610 Div. protective screens

Cross-sectional drawing: Pump with bearing B31

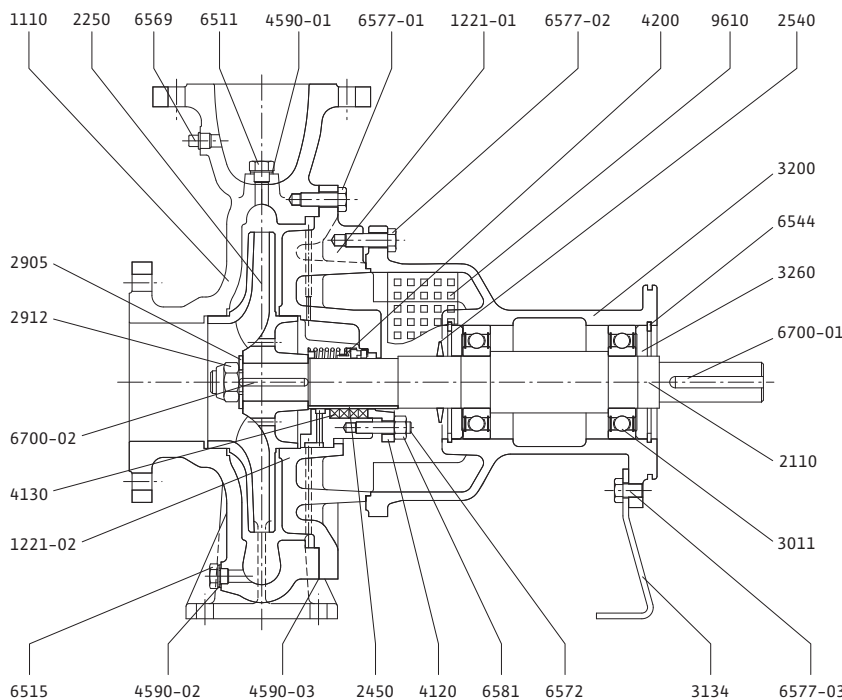

- 1110 Pump housing
- 1221-01 Housing cover
- 1221-02 Housing cover
- 2110 Pump shaft
- 2250 Impeller
- 2450 Shaft protection sleeve
- 2540 Thrower
- 2905 Washer
- 2912 Impeller nut
- 3011 Radial ball bearing
- 3134 Support foot
- 3200 Bearing housing
- 3260 Bearing cover
- 4120 Gland
- 4130 Stuffing box
- 4200 Mechanical seal
- 4590-01 Seal
- 4590-02 Seal
- 4590-03 Seal
- 6511 Filling screw
- 6515 Drain plug
- 6544 Circlip
- 6569 Plug
- 6572 Stud
- 6577-01 Hexagon head bolt
- 6577-02 Hexagon head bolt
- 6577-03 Hexagon head bolt
- 6581 Hexagon nut
- 6700-01 Key for coupling
- 6700-02 Key for impeller
- 9610 Div. protective screens

Norm pumps

Wilo-VeroNorm-NPG

Series description Wilo-VeroNorm-NPG

Cross-sectional drawing: Pump with bearings B51 and B52

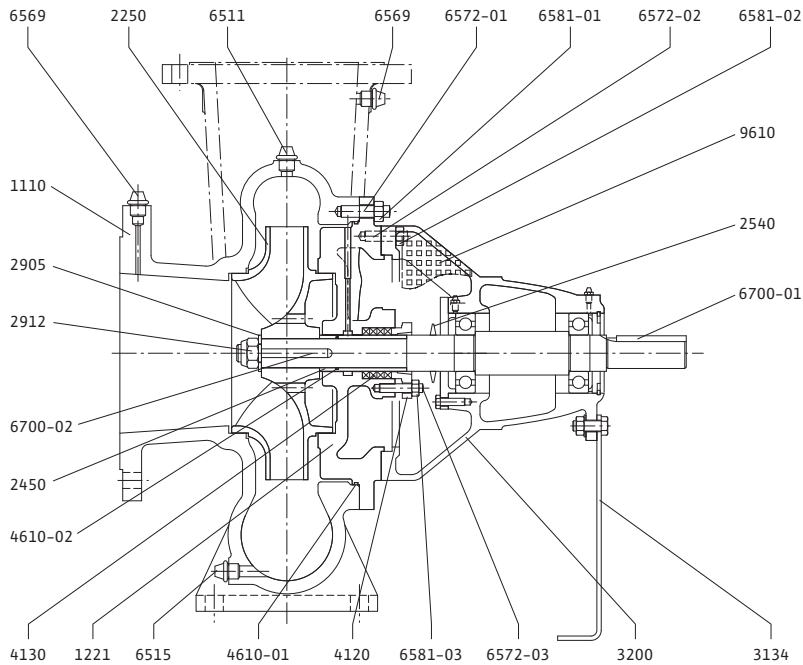

1110	Pump housing
1221	Housing cover
2250	Impeller
2450	Shaft protection sleeve
2540	Thrower
2905	Washer
2912	Impeller nut
3134	Support foot
3200	Bearing housing
4120	Gland
4130	Stuffing box
4610-01	O-ring
4610-02	O-ring
6511	Filling screw
6515	Drain plug
6569	Plug
6572-01	Stud
6572-02	Stud
6572-03	Stud
6581-01	Hexagon nut
6581-02	Hexagon nut
6581-03	Hexagon nut
6700-01	Key for coupling
6700-02	Key for impeller
9610	Div. protective screens

Cross-sectional drawing: Pump with bearings B61 and B62

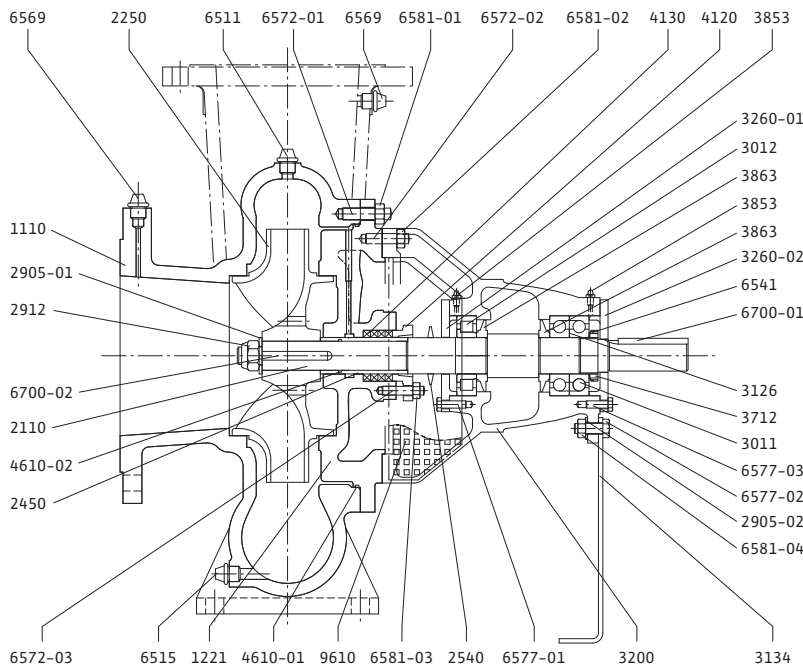

1110	Pump housing
1221	Housing cover
2110	Pump shaft
2250	Impeller
2450	Shaft protection sleeve
2540	Thrower
2905-01	Washer
2905-02	Washer
2912	Impeller nut
3011	Radial ball bearing
3012	Radial ball bearing
3126	Spacer
3134	Support foot
3200	Bearing housing
3260-01	Bearing cover
3260-02	Bearing cover
3712	Bearing nut
3853	Grease nipple
3863	Grease regulator
4120	Gland
4130	Stuffing box
4610-01	O-ring
4610-02	O-ring
6511	Filling screw
6515	Drain plug
6541	Lock washer
6569	Plug
6572-01	Stud
6572-02	Stud
6572-03	Stud
6577-...	Hexagon head bolt
6581-...	Hexagon nut
6700-01	Key coupling
6700-02	Key for impeller
9610	Div. protective screens

500 answers to FAQs.

Used 9000 times in 14 days.

1001 new suggestions.

For even more expert knowledge.

The knowledge database from Wilo.

Did you know? The knowledge database from Wilo will give you good and quick advice: with approx. 500 responses to the most frequently asked questions (FAQs) all about pumps, installations and systems. It is already being visited extensively by many skilled craftsmen. This is proven by 9000 utilisations in only 14 days, which we recently registered. The best thing: With every new question which you ask us with the contact form, we all become wiser together. Because the corresponding answer is naturally incorporated as soon as possible.

Know-how? We call this Pumpen Intelligenz.

www.wilo.com

WILO

Pumpen Intelligenz.

Norm pumps

Wilo-VeroNorm-NPG

Technical data Wilo-VeroNorm-NPG

Wilo-VeroNorm-NPG		
Approved fluids (other fluids on request)		
Heating water (in acc. with VDI 2035)	•	
Cooling and cold water	•	
Water-glycol mixture (with 20–40% vol. glycol and a fluid temperature of ≤ 40 °C; to 50%: mechanical seal on request)	• (starting from 10 vol. % glycol: performance check required)	
Permitted field of application		
Maximum inlet pressure on suction side, DN 200 [bar]	10	
Temperature range [°C] (fluids with mechanical seal)	see "Operating limits" table	
Ambient temperature, max. [°C]	+40	
Pipe connections		
Connection, nominal diameters DN – Pressure side – Suction side	65 – 500 100 – 500	
Flange (in acc. with EN 1092-2) – up to nominal diameter DN 150 – starting from nominal diameter DN 200	PN 10/16 PN 10	
Materials		
Pump housing – Standard version – Optional equipment	EN-GJL-250 EN-GJS-400-15 (available depending on the model, see "Operating limits" table)	
Housing cover – Standard version – Optional equipment	EN-GJL-250 EN-GJS-400-15 (available depending on the model, see "Operating limits" table)	
Impeller – Standard version – Special equipment	EN-GJL-250 bronze	
Shaft	Standard	Option
NPG 65/315; NPG 100/315; NPG 150/200; NPG 200/315; NPG 200/355; NPG 250/250; NPG 250/315; NPG 300/300	X30cr13	–
NPG 150/500; NPG 200/400; NPG 200/500; NPG 250/355; NPG 250/400; NPG 250/500; NPG 300/400; NPG 300/450; NPG 300/500; NPG 350/350; NPG 400/500; NPG 400/650; NPG 500/500	C35E	X20cr13
NPG 200/250	C38	–
Mechanical seal – Standard version – Other mechanical seals	AQ1EGG on request (depending on the fluid pumped, see "Operating limits" table)	
Non-cooled stuffing box	(version at no additional charge)	

Technical data Wilo-VeroNorm-NPG

Wilo-VeroNorm-NPG	
Bearing housing	
Pump type	bearing housing type
NPG 150-200	B21
NPG 200-250	B3
NPG 65-315; NPG 100-315	B31
NPG 200-315; NPG 200-355 NPG 250-250; NPG 250-315 NPG 300-300	B40
NPG 200-400; NPG 250-355 NPG 250-400; NPG 300-400	B51
NPG 150-500; NPG 200-500 NPG 250-500; NPG 300-450 NPG 350-350	B52
NPG 300-500; NPG 400-500 NPG 400-650	B61
NPG 500-500	B62
Motor/electronics	
Factory IEC norm motor	•
West European brand production	special version at additional charge
Speed [rpm] – Standard version	2900/1450/960
Protection class	IP 55
Insulation class	F
PTC thermistor sensor	• (tripping unit required)
Motor protection switch	is to be provided for onsite installation
Energy efficiency classification – Standard version – Special version (at additional charge)	EFF 2 EFF 1
Motor windings – up to 4 kW – via 4 kW	230 V Δ / 400 VY, 50 Hz 400 V Δ / 690 VY, 50 Hz
Other voltages/frequencies	special version at additional charge
Direct current	special version at additional charge
Explosion-protected versions	special version at additional charge
Speed control	
Wilo control devices External frequency converter	additional equipment at additional charge see "Switchgears and Control Devices" section

• = available or standard version

Norm pumps

Wilo-VeroNorm-NPG

Operating limits Wilo-VeroNorm-NPG

Operating limits: Pressure and temperature

Pump type	Seals	Material	Pressure p	Temperature T
NPG 65/315 NPG 100/315	Mechanical seal (SiC/carbon/EPDM)	EN-GJL-250	p ≤ 16 bar	-20°C ≤ T ≤ 120°C
			p ≤ 10 bar	120°C ≤ T ≤ 140°C
NPG 150/500	Mechanical seal (SiC/carbon/EPDM)	EN-GJL-250	p ≤ 16 bar	-20°C ≤ T ≤ 120°C
			p ≤ 10 bar	120°C ≤ T ≤ 140°C
NPG 150/200 NPG 250/250 NPG 300/300	Mechanical seal (SiC/carbon/EPDM)	EN-GJL-250	p ≤ 4 bar	-20°C ≤ T ≤ 120°C
		EN-GJS-400-15*	p ≤ 6 bar	-20°C ≤ T ≤ 120°C
NPG 200/315 NPG 200/355 NPG 250/315	Mechanical seal (SiC/carbon/EPDM)	EN-GJL-250	p ≤ 8 bar	-20°C ≤ T ≤ 120°C
		EN-GJS-400-15*	p ≤ 12 bar	-20°C ≤ T ≤ 140°C
NPG 200/400 NPG 250/355 NPG 250/400 NPG 300/400 NPG 300/450	Mechanical seal (SiC/carbon/EPDM)	EN-GJL-250	p ≤ 8 bar	-20°C ≤ T ≤ 120°C
		EN-GJS-400-15*	p ≤ 12 bar	-20°C ≤ T ≤ 140°C
NPG 200/500 NPG 250/500 NPG 300/500	Mechanical seal (SiC/carbon/EPDM)	EN-GJL-250	p ≤ 10 bar	-20°C ≤ T ≤ 120°C
		EN-GJS-400-15*	p ≤ 15 bar	-20°C ≤ T ≤ 140°C
NPG 350/350 NPG 500/500	Mechanical seal (SiC/carbon/EPDM)	EN-GJL-250	p ≤ 4 bar	-20°C ≤ T ≤ 120°C
		EN-GJS-400-15*	p ≤ 6 bar	-20°C ≤ T ≤ 120°C
NPG 400/500 NPG 400/650	Mechanical seal (SiC/carbon/EPDM)	EN-GJL-250	p ≤ 6.5 bar	-20°C ≤ T ≤ 120°C
		EN-GJS-400-15*	p ≤ 10 bar	-20°C ≤ T ≤ 120°C
NPG 200/250	Mechanical seal (SiC/ceramic/EPDM)	EN-GJL-250	p ≤ 8 bar	-20°C ≤ T ≤ 110°C
		EN-GJL-250	p ≤ 8 bar	T ≤ 105°C

* Available upon request.

Additional options are available:

- Housing stationary wear rings
- Housing cover stationary wear rings
- Additional materials (available, depending on the model):
 - Housing: cast iron with nodular graphite
 - Impeller: bronze
- Tailored mechanical seal for high pressure on suction side

Norm pumps

Wilo-VeroNorm-NPG



Pump curves Wilo-VeroNorm-NPG (2-pole)

Wilo-VeroNorm-NPG 65/315

Speed 2900 [rpm]

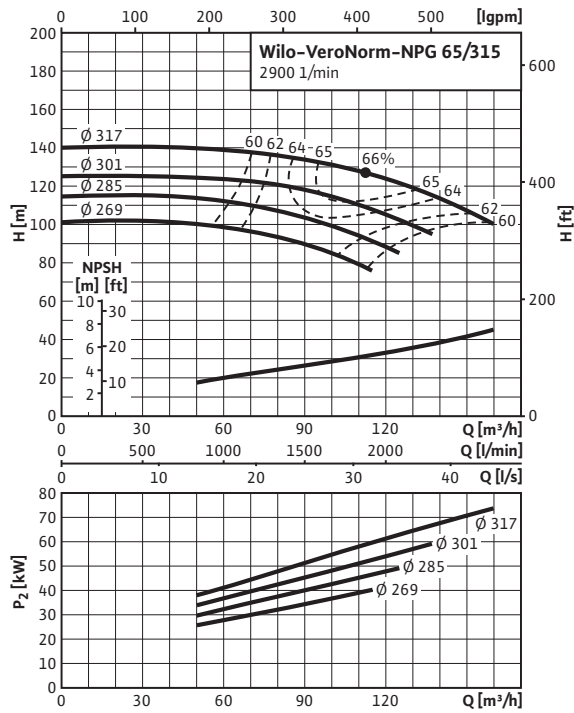

Wilo-VeroNorm-NPG 100/315

Speed 2900 [rpm]

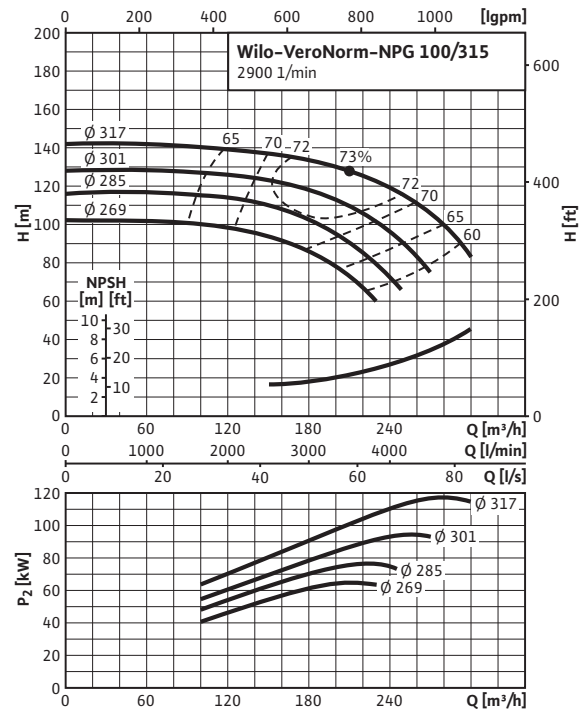

Norm pumps

Wilco-VeroNorm-NPG

Pump curves Wilco-VeroNorm-NPG (4-pole)

Wilco-VeroNorm-NPG 150/200

Speed 1450 [rpm]

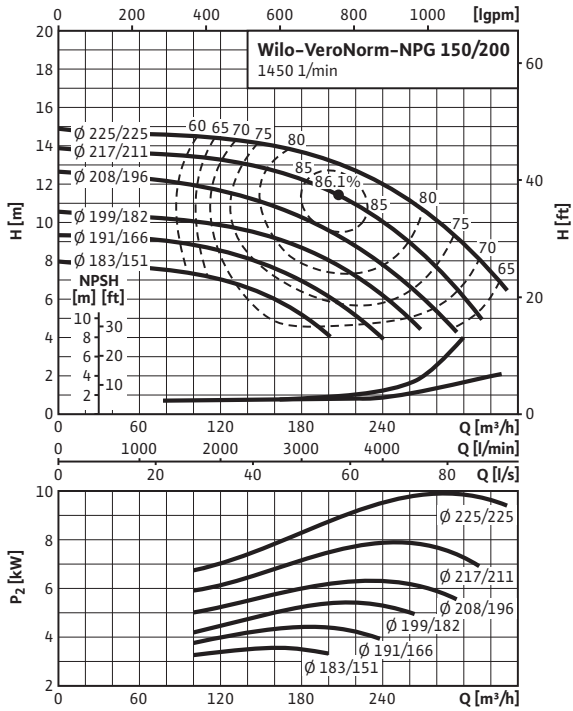

Wilco-VeroNorm-NPG 150/500

Speed 1450 [rpm]

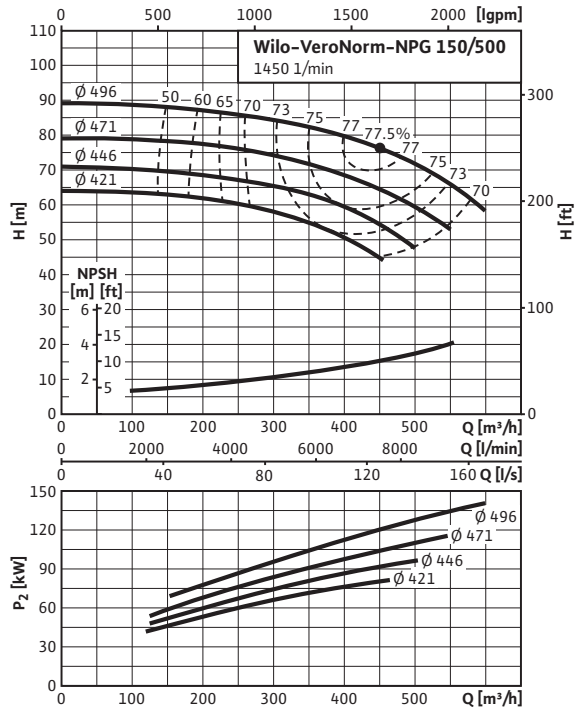

Wilco-VeroNorm-NPG 200/250

Speed 1450 [rpm]

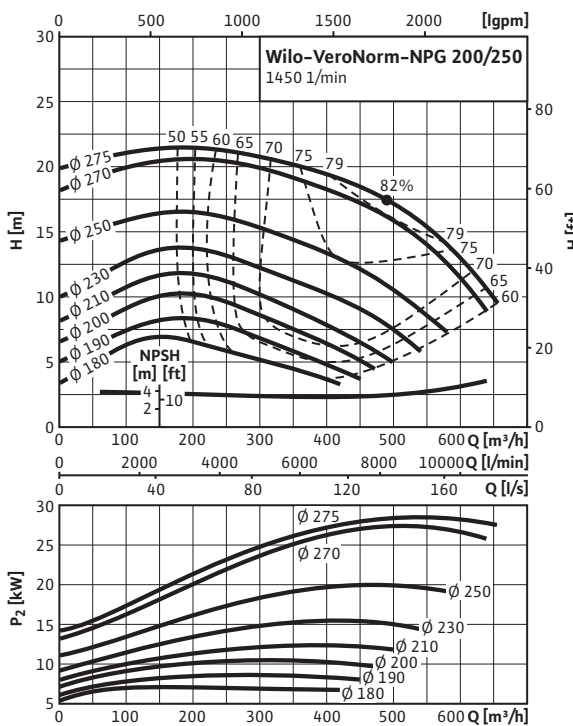

Wilco-VeroNorm-NPG 200/315

Speed 1450 [rpm]

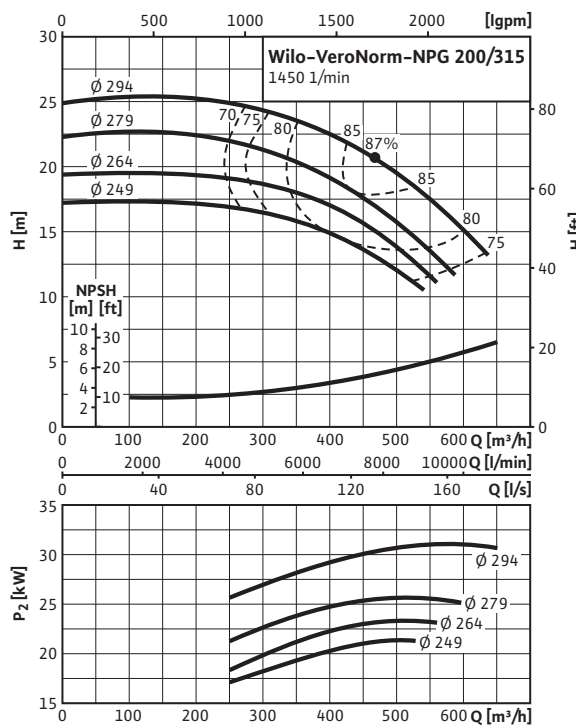

Norm pumps

Wilo-VeroNorm-NPG



Pump curves Wilo-VeroNorm-NPG (4-pole)

Wilo-VeroNorm-NPG 200/355

Speed 1450 [rpm]

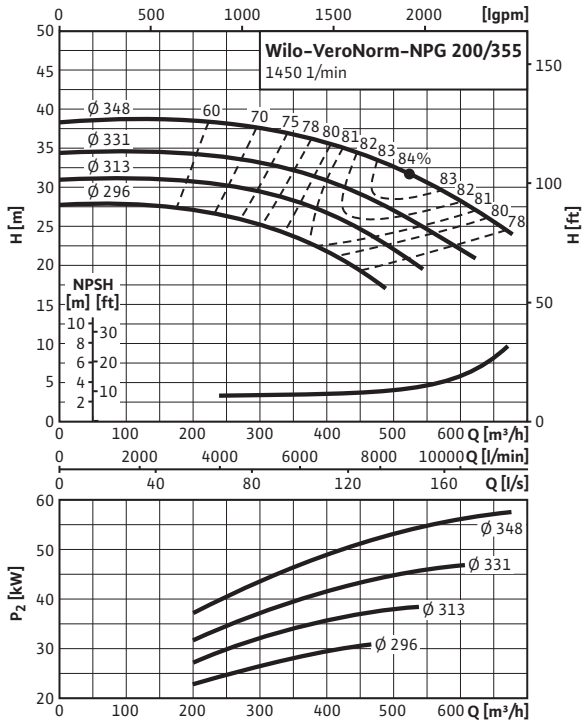

Wilo-VeroNorm-NPG 200/400

Speed 1450 [rpm]

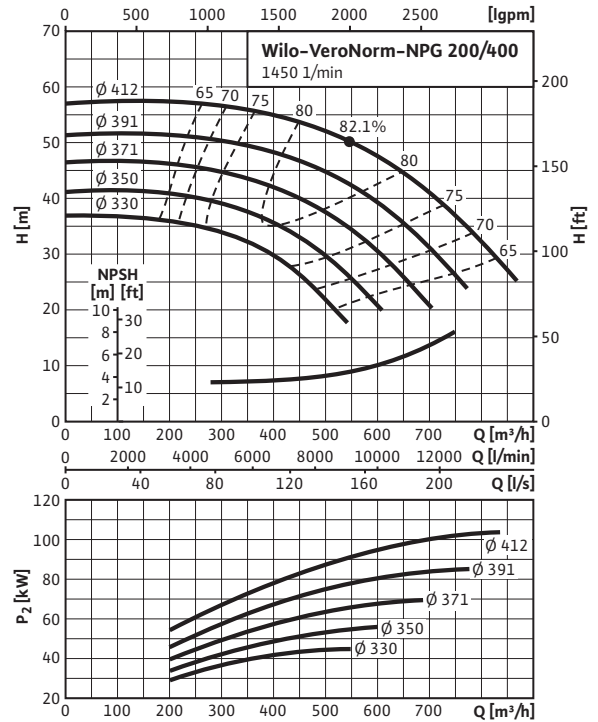

Wilo-VeroNorm-NPG 200/500

Speed 1450 [rpm]

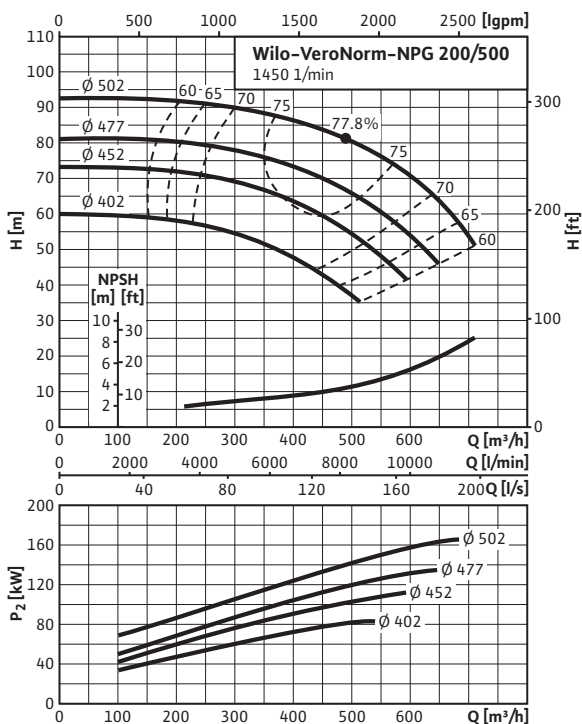

Wilo-VeroNorm-NPG 250/250

Speed 1450 [rpm]

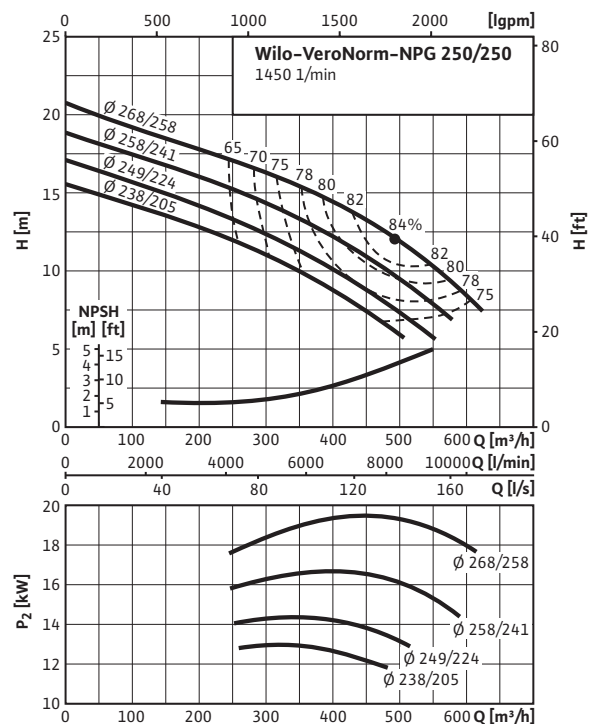

Norm pumps

Wilo-VeroNorm-NPG

Pump curves Wilo-VeroNorm-NPG (4-pole)

Wilo-VeroNorm-NPG 250/315

Speed 1450 [rpm]

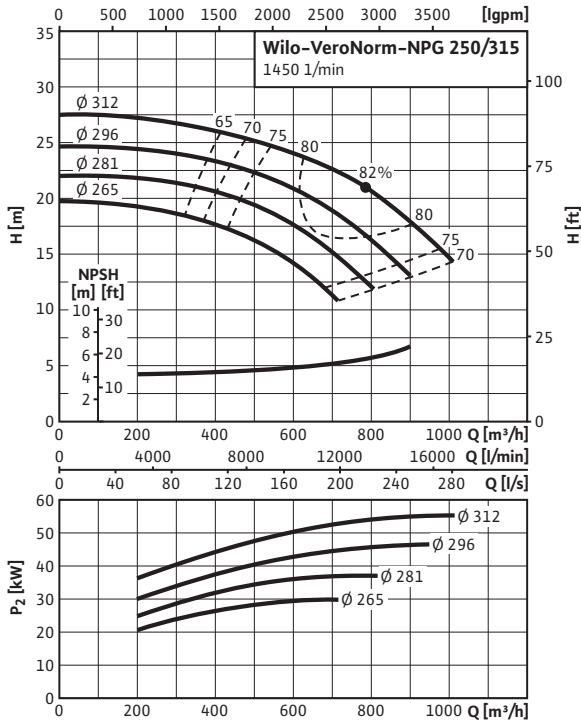

Wilo-VeroNorm-NPG 250/355

Speed 1450 [rpm]

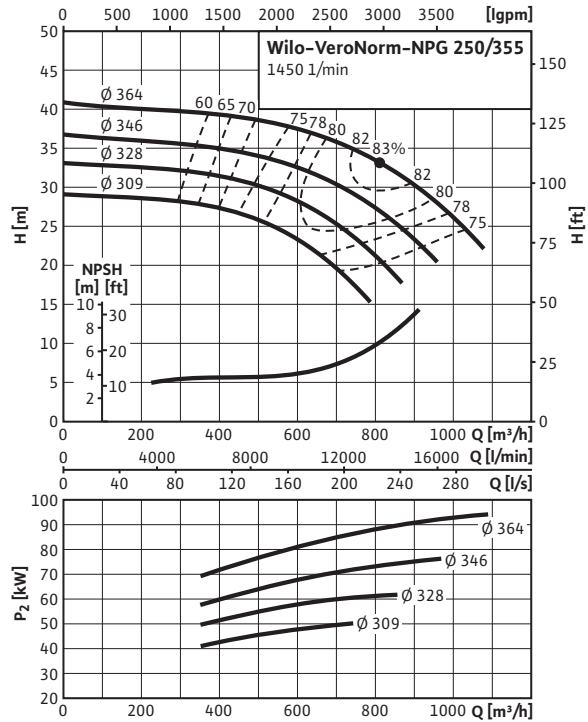

Wilo-VeroNorm-NPG 250/400

Speed 1450 [rpm]

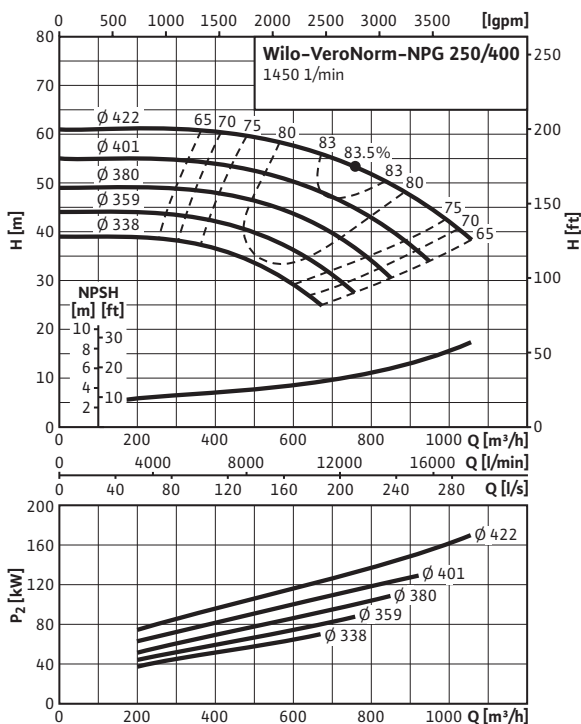

Wilo-VeroNorm-NPG 250/500

Speed 1450 [rpm]

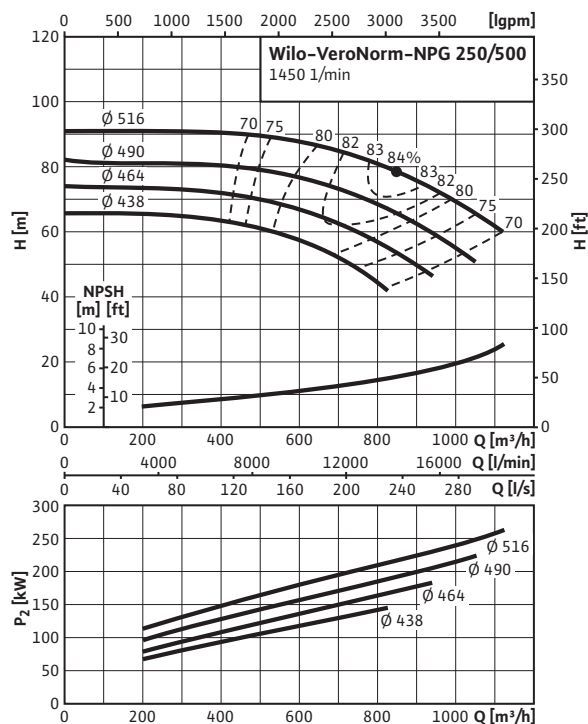

Pump curves Wilo-VeroNorm-NPG (4-pole)

Wilo-VeroNorm-NPG 300/300

Speed 1450 [rpm]

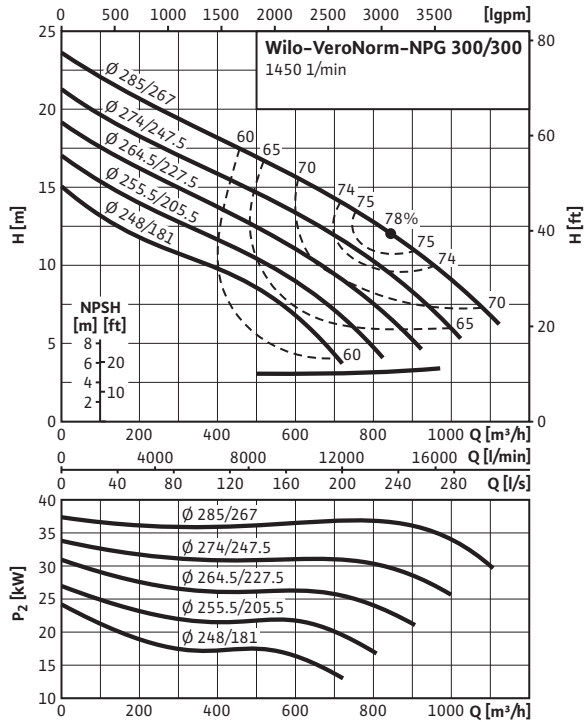

Wilo-VeroNorm-NPG 300/400

Speed 1450 [rpm]

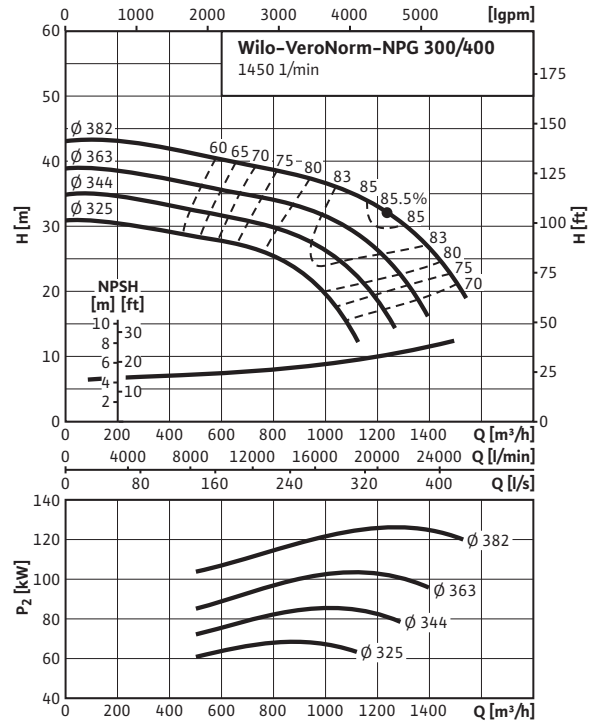

Wilo-VeroNorm-NPG 300/450

Speed 1450 [rpm]

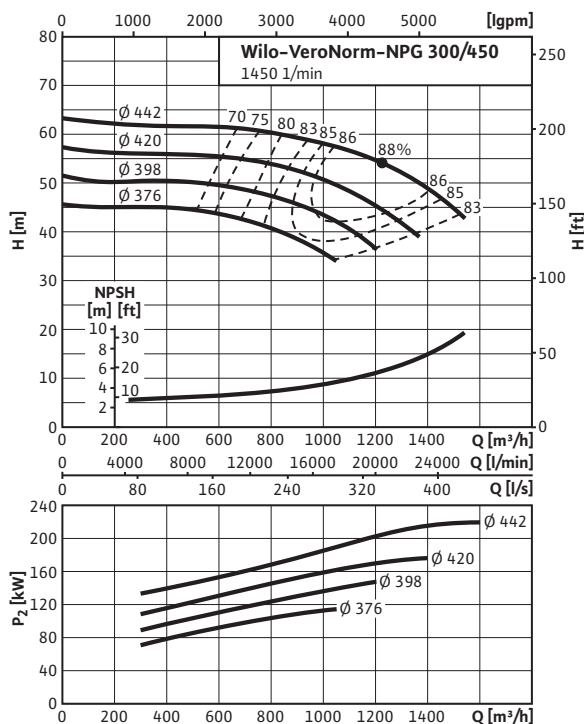

Wilo-VeroNorm-NPG 300/500

Speed 1450 [rpm]

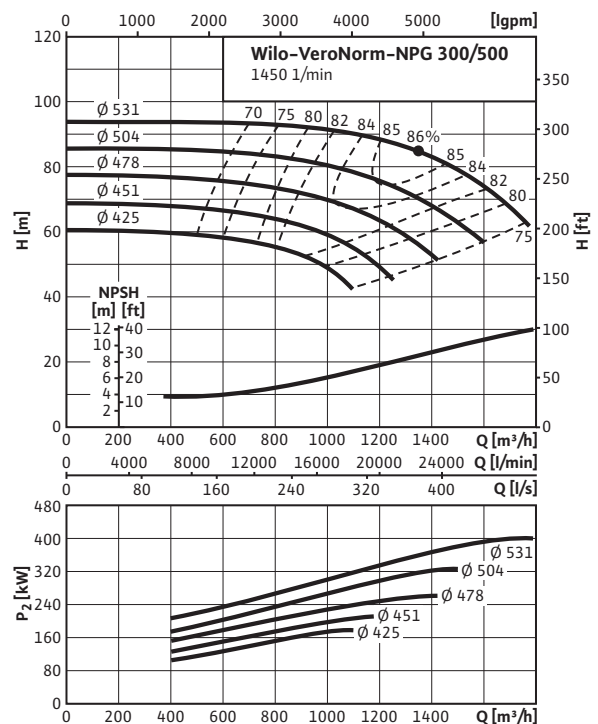

Norm pumps

Wilo-VeroNorm-NPG

Pump curves Wilo-VeroNorm-NPG (6-pole)

Wilo-VeroNorm-NPG 350/350

Speed 1450 [rpm]

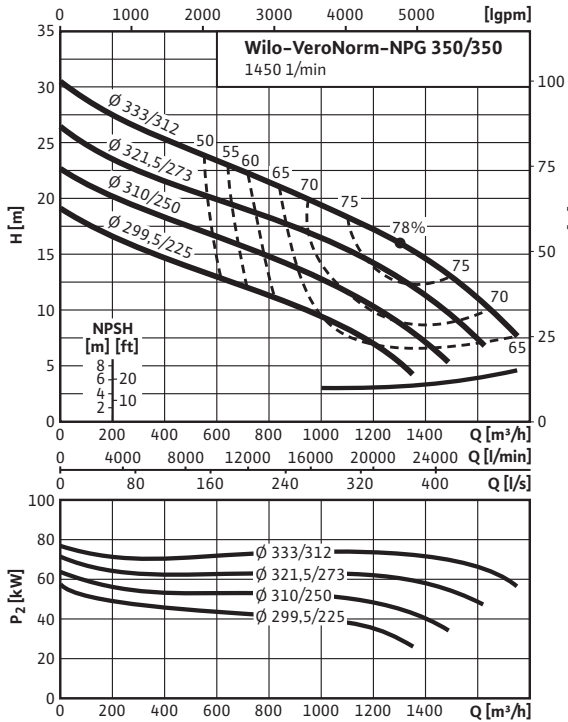

Wilo-VeroNorm-NPG 400/500

Speed 960 [rpm]

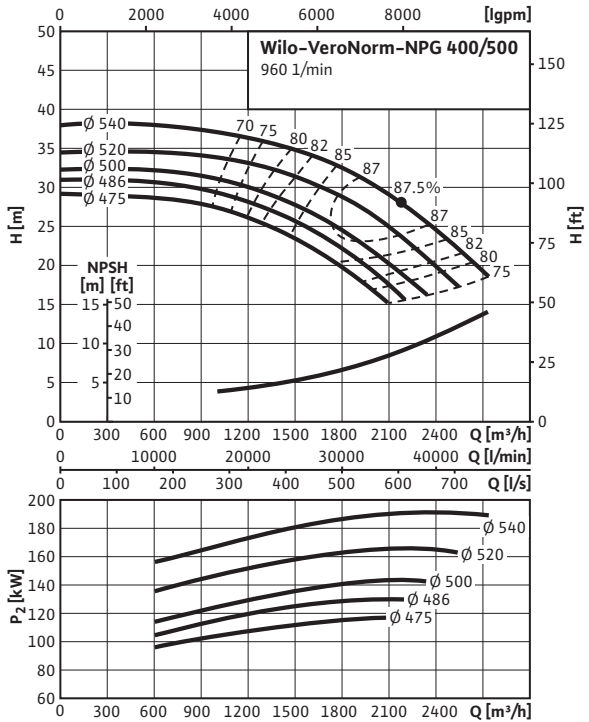

Wilo-VeroNorm-NPG 400/650

Speed 960 [rpm]

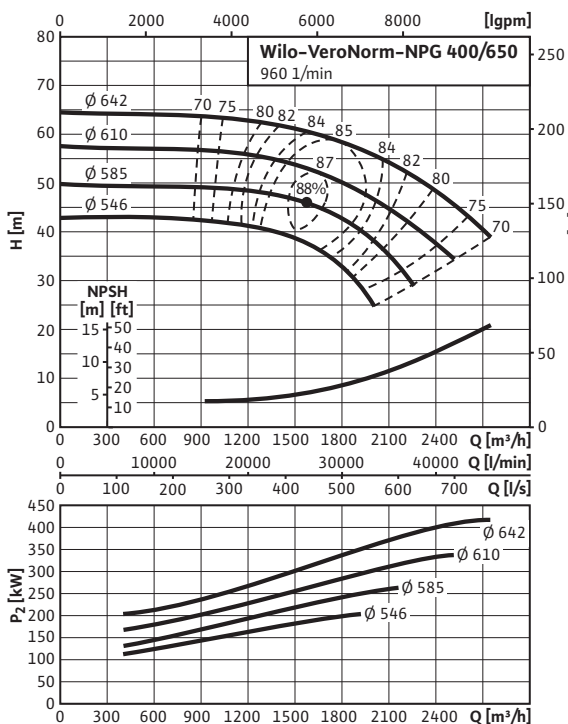

Wilo-VeroNorm-NPG 500/500

Speed 960 [rpm]

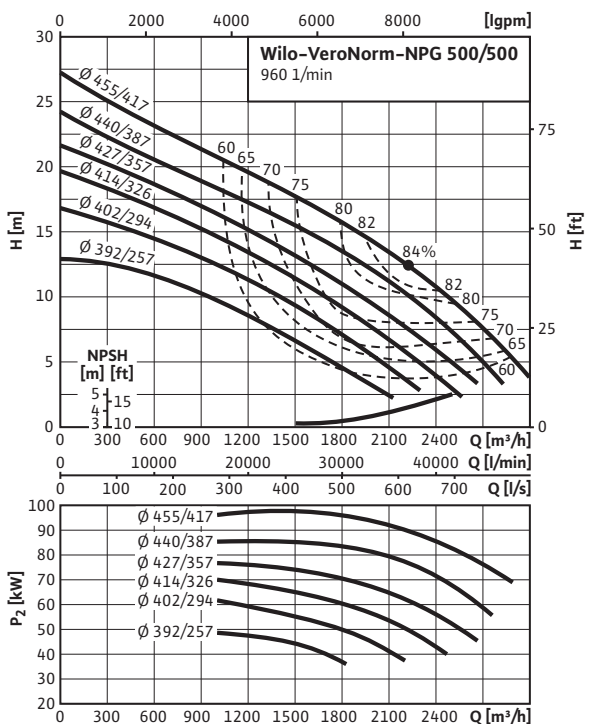

Dimensions, weights Wilo-VeroNorm-NPG

Dimension drawing: Bare shaft pumps

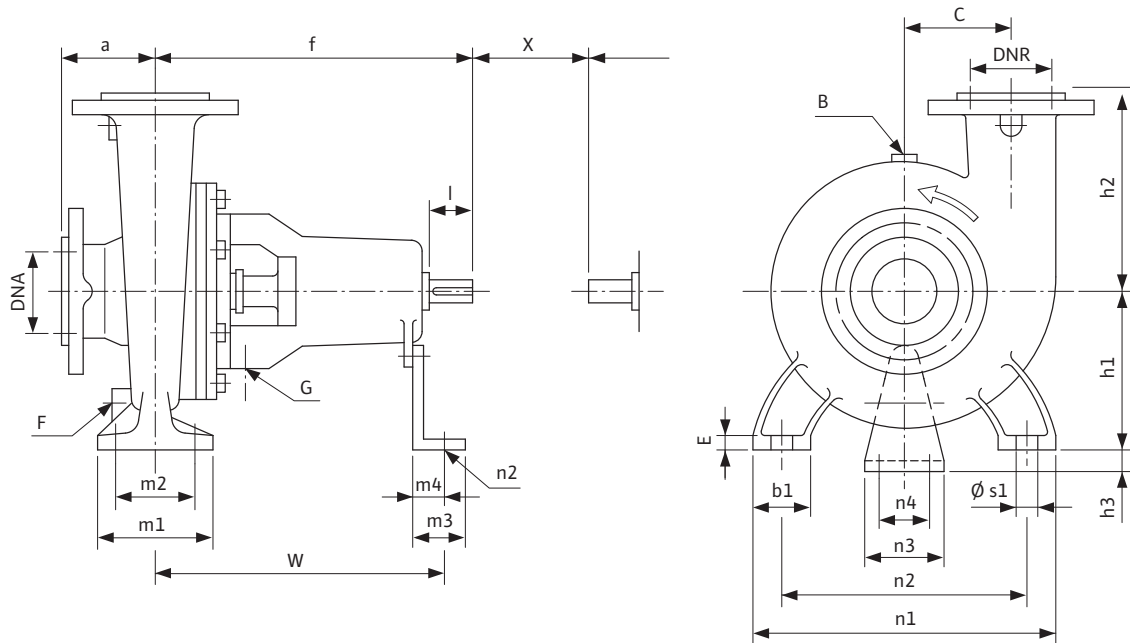

- Detail B: Filling
- Detail G: Drain
- Detail F: Drain
- Dimension x: Distance between the two shaft ends for dismantling, without removing the motor (coupling with spacer)

Shaft details

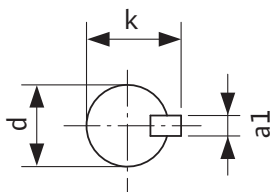

Flange dimensions

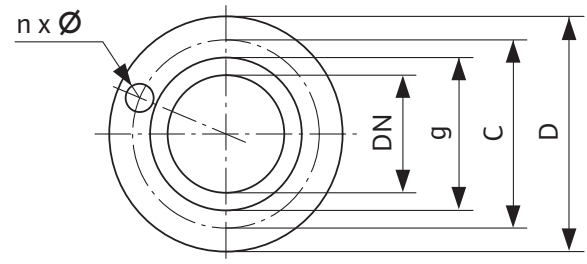

Norm pumps

Wilo-VeroNorm-NPG

Dimensions, weights Wilo-VeroNorm-NPG

Dimensions, weights – Pumps with bare shaft end

NPG ...	Weight [kg]	DNA (suction side)	DNR (pressure side)	Pump							Fixing tab						Shaft end			Crotch					Ventilation pipe		
				a	f	h1	h2	h3	C	b1	m1	m2	n1	n2	s1	E	x	l	w	m3	m4	n3	n4	s2	f	G	B
				[mm]																							
65/315	134	100	65	125	530	225	280	-	-	80	160	120	400	315	M16	16	140	110	370	60	42	160	110	M12	3/8	1/2	3/8
100/315	152	125	100	140	530	250	315	-	-	80	160	120	400	315	M16	16	140	110	370	60	42	160	110	M12	3/8	1/2	3/8
150/200	120	150	150	150	500	250	220	-	180	80	160	120	400	315	M16	15	140	80	367	60	43	160	110	M12	3/8	1/2	3/8
150/500	450	200	150	205	730	400	440	40	290	120	300	250	710	600	M24	18	190	100	640	120	60	160	100	M12	1/2	1/2	1/2
200/250	215	250	200	180	530	315	400	-	-	100	200	140	550	450	M24	18	140	110	370	50	32	140	110	M14	1/2	1/2	1/2
200/315	260	250	200	225	550	355	355	40	246	120	250	200	600	500	M22	22	175	110	470	110	55	140	80	M10	1/2	1/2	1/2
200/355	265	250	200	230	550	355	400	40	235	120	250	200	600	500	M22	22	180	110	470	110	55	140	80	M10	1/2	1/2	1/2
200/400	360	250	200	225	730	375	500	40	255	120	250	200	600	500	M22	22	200	100	640	120	60	160	100	M10	1/2	1/2	1/2
200/500	400	250	200	205	730	400	560	40	270	120	300	250	710	600	M24	25	190	100	640	120	60	160	100	M12	1/2	1/2	1/2
250/250	260	250	250	200	580	355	355	40	240	120	250	200	630	505	M22	23	200	110	500	110	55	140	80	M10	1/2	1/2	1/2
250/315	330	300	250	250	550	425	295	40	295	120	300	250	710	600	M24	25	180	110	470	110	55	140	80	M10	1/2	1/2	1/2
250/355	370	300	250	250	730	400	400	40	275	120	300	250	710	600	M24	25	190	100	640	120	60	160	100	M12	1/2	1/2	1/2
250/400	415	300	250	250	730	400	500	40	265	120	300	250	710	600	M24	25	210	100	640	120	60	160	100	M12	1/2	1/2	1/2
250/500	500	300	250	250	730	425	560	40	285	120	300	250	710	600	M24	25	200	100	640	120	60	160	100	M12	1/2	1/2	1/2
300/300	370	300	300	225	595	450	355	40	330	140	335	280	710	600	M24	25	220	110	530	140	70	160	100	M12	1/2	1/2	1/2
300/400	480	350	300	300	730	475	400	40	330	140	315	250	800	670	M27	28	210	100	660	140	70	160	100	M12	1/2	1/2	1/2
300/450	550	350	300	300	730	475	560	40	310	140	315	250	800	670	M27	28	230	100	660	140	70	160	100	M12	1/2	1/2	1/2
300/500	710	350	300	300	864	500	600	40	330	140	335	280	800	670	M27	28	240	140	730	160	80	200	120	M12	1/2	1/2	1/2
350/350	600	350	350	250	775	500	500	40	390	140	400	315	800	670	M27	30	240	100	715	160	80	200	120	M12	1/2	1/2	1/2
400/500	980	450	400	400	920	630	600	40	420	200	400	315	1120	950	M27	35	300	140	786	160	80	200	120	M12	1/2	1/2	1/2
400/650	1250	450	400	350	894	630	760	40	410	200	400	315	1120	950	M27	35	300	140	760	160	80	200	120	M12	1/2	1/2	1/2
500/500	1450	500	500	400	939	650	500	40	490	200	550	450	1120	950	M27	35	300	140	805	160	80	200	120	M12	1/2	1/2	1/2

Flange dimensions – Pumps with bare shaft end

DNR... (pressure side)	PN	D	C	G	n x Ø
	[-]	[mm]			[pcs. x mm]
65	10/16	185	145	118	4 x 19
100	10/16	220	180	156	8 x 19
125	10/16	250	210	184	8 x 19
150	10/16	285	240	211	8 x 23
200	10	340	295	266	8 x 23
250	10	395	350	320	12 x 23
300	10	445	400	370	12 x 23
350	10	505	460	430	16 x 23
400	10	565	515	482	16 x 28
500	10	670	620	585	20 x 28

Dimensions, weights Wilo-VeroNorm-NPG

Flange dimensions – Pumps with bare shaft end

NPG ...	D	k	a1
		[mm]	
65/315	42	45	12
100/315	42	45	12
150/200	32	35	10
150/500	55	59	16
200/250	42	45	12
200/315	42	45	12
200/355	42	45	12
200/400	55	59	16
200/500	55	59	16
250/250	42	45	12
250/315	42	45	12
250/355	55	59	16
250/400	55	59	16
250/500	55	59	16
300/300	42	45	12
300/400	55	59	16
300/450	55	59	16
300/500	70	74.5	20
350/350	55	59	16
400/500	70	74.5	20
400/650	70	74.5	20
500/500	70	74.5	20

Norm pumps

Wilo-VeroNorm-NPG

Dimensions, weights Wilo-VeroNorm-NPG

Dimension drawing: Complete installation on baseplate with motor

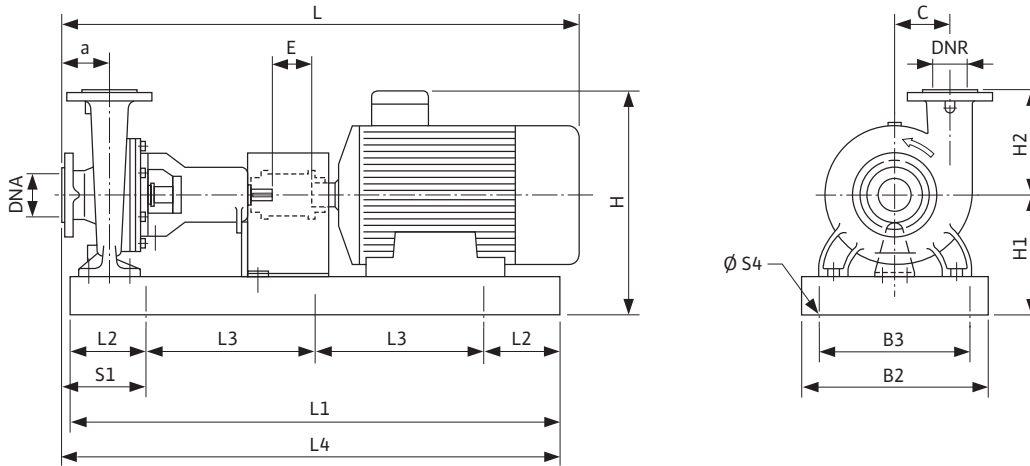

The length and width of the base block should be approx. 15 to 20 cm greater than the outer dimensions of the pump baseplate. Dimension L: Approximate dimension, dependent on brand of motor.

Dimensions, weights – Complete installation on baseplate with motor

NPG...	Motor data				Weight [kg]	DNA (suction side)	DNR (pressure side)	(Dimensions with spacer)														
	Motor power	Motor size	Pole	Speed				a	H	H1	H2	S4	I	L1	L2	L3	L4	S1	B2	B3	C	E
	[kW]	[-]	[No.]	[rpm]				[mm]														
65/315	30	200L	2	2900	575	100	65	125	563	328	280	4 x 29	1595	1460	260	-	1460	260	610	550	-	140
	37	200L	2	2900	595	100	65	125	563	328	280	4 x 29	1595	1460	260	-	1460	260	610	550	-	140
	45	225M	2	2900	697	100	65	125	588	328	280	4 x 29	1635	1660	300	-	1660	300	660	600	-	140
	55	250M	2	2900	794	100	65	125	613	348	280	4 x 29	1745	1660	300	-	1660	300	660	600	-	140
	75	280S/M	2	2900	872	100	65	125	783	403	280	4 x 29	1855	1660	300	-	1660	300	660	600	-	140
	90	280S/M	2	2900	945	100	65	125	783	403	280	4 x 29	1855	1660	300	-	1660	300	660	600	-	140
100/315	55	250M	2	2900	812	125	100	140	633	373	315	4 x 29	1760	1660	300	-	1675	315	660	600	-	140
	75	280S/M	2	2900	963	125	100	140	803	403	315	4 x 29	1870	1660	300	-	1675	315	660	600	-	140
	90	280S/M	2	2900	890	125	100	140	803	403	315	4 x 29	1870	1660	300	-	1675	315	660	600	-	140
	110	315 S/	2	2900	1082	125	100	140	973	438	315	4 x 29	2160	1860	330	-	1875	345	730	670	-	140
150/200	132	315 S/	2	2900	1615	125	100	140	973	438	315	4 x 29	2160	1860	330	-	1875	345	730	670	-	140
	5.5	132S	4	1450	340	150	150	150	501	353	220	4 x 24	1225	1310	235	-	1340	265	540	490	180	140
	7.5	132M	4	1450	365	150	150	150	528	353	220	4 x 24	1260	1310	235	-	1340	265	540	490	180	140
	9	132M	4	1450	365	150	150	150	528	353	220	4 x 24	1260	1310	235	-	1340	265	540	490	180	140
	11	160M	4	1450	460	150	150	150	603	353	220	4 x 24	1420	1460	260	-	1490	290	610	550	180	140
150/500	15	160L	4	1450	485	150	150	150	603	353	220	4 x 24	1465	1460	260	-	1490	290	610	550	180	140
	90	280S/M	4	1450	1660	200	150	205	986	523	440	4 x 29	2116	2140	370	-	2165	395	860	790	290	200
	110	315 S/	4	1450	1720	200	150	205	1050	523	440	4 x 29	2257	2140	370	-	2165	395	860	790	290	200
	132	315 S/	4	1450	1870	200	150	205	1050	523	440	4 x 29	2257	2140	370	-	2165	395	860	790	290	200
	160	315 S/	4	1450	1870	200	150	205	1050	523	440	4 x 29	2300	2140	370	-	2165	395	860	790	290	200

Norm pumps

Wilo-VeroNorm-NPG



Dimensions, weights Wilo-VeroNorm-NPG

Dimensions, weights – Complete installation on baseplate with motor (continued)

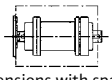
NPG...	Motor data				Weight [kg]	DNA (suction side)	DNR (pressure side)											 (Dimensions with spacer)									
	Motor performance [kW]	Motor size [-]	Pole [No.]	Speed [rpm]				a	H	H1	H2	S4	I	[mm]													
														L1	L2	L3	L4	S1	B2	B3	C	E					
200/250	5.5	132S	4	1450	562	250	200	180	617	438	400	4 x 29	1330	1860	330	-	1900	370	730	670	-	140					
	7.5	132M	4	1450	583	250	200	180	617	438	400	4 x 29	1330	1860	330	-	1900	370	730	670	-	140					
	9	132M	4	1450	592	250	200	180	617	438	400	4 x 29	1330	1860	330	-	1900	370	730	670	-	140					
	11	160M	4	1450	600	250	200	180	638	438	400	4 x 29	1440	1860	330	-	1900	370	730	670	-	140					
	15	160L	4	1450	614	250	200	180	638	438	400	4 x 29	1440	1860	330	-	1900	370	730	670	-	140					
	18.5	180M	4	1450	643	250	200	180	645	438	400	4 x 29	1485	1860	330	-	1900	370	730	670	-	140					
	22	180L	4	1450	651	250	200	180	645	438	400	4 x 29	1485	1860	330	-	1900	370	730	670	-	140					
	30	200L	4	1450	700	250	200	180	673	438	400	4 x 29	1520	1860	330	-	1900	370	730	670	-	140					
	37	225S	4	1450	750	250	200	180	698	438	400	4 x 29	1620	1860	330	-	1900	370	730	670	-	140					
	45	225M	4	1450	790	250	200	180	698	438	400	4 x 29	1620	1860	330	-	1900	370	730	670	-	140					
200/315	22	180L	4	1450	730	250	200	225	685	478	355	4 x 29	1590	1860	330	-	1920	390	730	670	246	180					
	30	200L	4	1450	790	250	200	225	713	478	355	4 x 29	1670	1860	330	-	1920	390	730	670	246	180					
	37	225S	4	1450	840	250	200	225	738	478	355	4 x 29	1730	1860	330	-	1920	390	730	670	246	180					
	45	225M	4	1450	880	250	200	225	738	478	355	4 x 29	1780	1860	330	-	1920	390	730	670	246	180					
200/355	30	200L	4	1450	790	250	200	230	713	478	400	4 x 29	1625	1860	330	-	1925	395	730	670	235	180					
	37	225S	4	1450	840	250	200	230	738	478	400	4 x 29	1725	1860	330	-	1925	395	730	670	235	180					
	45	225M	4	1450	880	250	200	230	738	478	400	4 x 29	1785	1860	330	-	1925	395	730	670	235	180					
	55	250M	4	1450	900	250	200	230	738	478	400	4 x 29	1854	1860	330	-	1925	395	730	670	235	180					
	75	280S/	4	1450	1350	250	200	230	941	478	400	4 x 29	1995	1860	330	-	1925	395	730	670	235	180					
200/400	45	225M	4	1450	980	250	200	225	758	498	500	4 x 29	1920	1860	330	-	1920	390	730	670	255	200					
	55	250M	4	1450	1010	250	200	225	758	498	500	4 x 29	1939	1860	330	-	1920	390	730	670	255	200					
	75	280S/	4	1450	1500	250	200	225	961	498	500	4 x 29	2090	2140	370	-	2210	440	860	790	255	200					
	90	280S/	4	1450	1570	250	200	225	961	498	500	4 x 29	2140	2140	370	-	2210	440	860	790	255	200					
	110	315 S/	4	1450	1630	250	200	225	990	498	500	4 x 29	2275	2140	370	-	2210	440	860	790	255	200					
	132	315 S/	4	1450	1770	250	200	225	990	498	500	4 x 29	2350	2140	370	-	2210	440	860	790	255	200					
200/500	55	250M	4	1450	1090	250	200	205	783	523	560	4 x 29	1919	2140	370	-	2165	395	860	790	270	200					
	75	280S/	4	1450	1540	250	200	205	986	523	560	4 x 29	2095	2140	370	-	2165	395	860	790	270	200					
	90	280S/	4	1450	1610	250	200	205	986	523	560	4 x 29	2150	2140	370	-	2165	395	860	790	270	200					
	110	315 S/	4	1450	1670	250	200	205	1015	523	560	4 x 29	2260	2140	370	-	2165	395	860	790	270	200					
	132	315 S/	4	1450	1810	250	200	205	1015	523	560	4 x 29	2260	2140	370	-	2165	395	860	790	270	200					
	160	315 S/	4	1450	1810	250	200	205	1015	523	560	4 x 29	2330	2140	370	-	2165	395	860	790	270	200					
	185	315 S/	4	1450	1800	250	200	205	1015	523	560	4 x 29	2330	2140	370	-	2165	395	860	790	270	200					
	200	315B	4	1450	2400	250	200	205	910	587	560	6 x 19	2705	2270	200	935	2310	240	760	710	270	200					
	250	355M/	4	1450	2650	250	200	205	910	587	560	6 x 19	2970	2550	200	1075	2590	240	760	710	270	200					
250/250	15	160L	4	1450	760	250	250	200	678	478	355	4 x 29	1590	2140	370	-	2185	415	860	790	240	200					
	18.5	180M	4	1450	790	250	250	200	685	478	355	4 x 29	1590	2140	370	-	2185	415	860	790	240	200					
	22	180L	4	1450	800	250	250	200	685	478	355	4 x 29	1620	2140	370	-	2185	415	860	790	240	200					
	30	200L	4	1450	850	250	250	200	713	478	355	4 x 29	1700	2140	370	-	2185	415	860	790	240	200					

Norm pumps

Wilo-VeroNorm-NPG

Dimensions, weights Wilo-VeroNorm-NPG

Dimensions, weights – Complete installation on baseplate with motor (continued)

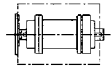
NPG...	Motor data				Weight [kg]	DNA (suction side)	DNR (pressure side)	 (Dimensions with spacer)														
	Motor performance	Motor size	Pole	Speed				a	H	H1	H2	S4	I	L1	L2	L3	L4	S1	B2	B3	C	E
	[kW]	[-]	[No.]	[rpm]				[mm]														
250/315	30	200L	4	1450	910	300	250	250	783	548	400	4 x 29	1695	2140	370	-	2210	440	860	790	295	180
	37	225S	4	1450	950	300	250	250	808	548	400	4 x 29	1811	2140	370	-	2210	440	860	790	295	180
	45	225M	4	1450	990	300	250	250	808	548	400	4 x 29	1811	2140	370	-	2210	440	860	790	295	180
	55	250M	4	1450	1010	300	250	250	808	548	400	4 x 29	1875	2140	370	-	2210	440	860	790	295	180
	75	280S/	4	1450	1460	300	250	250	1011	548	400	4 x 29	1910	2140	370	-	2210	440	860	790	295	180
250/355	55	250M	4	1450	1060	300	250	250	783	523	400	4 x 29	2103	2140	370	-	2210	440	860	790	275	200
	75	280S/	4	1450	1510	300	250	250	986	523	400	4 x 29	2150	2140	370	-	2210	440	860	790	275	200
	90	280S/	4	1450	1580	300	250	250	986	523	400	4 x 29	2180	2140	370	-	2210	440	860	790	275	200
	110	315 S/	4	1450	1640	300	250	250	1015	523	400	4 x 29	2305	2140	370	-	2210	440	860	790	275	200
	132	315 S/	4	1450	1785	300	250	250	1015	523	400	4 x 29	2305	2140	370	-	2210	440	860	790	275	200
250/400	55	250M	4	1450	1110	300	250	250	783	523	500	4 x 29	2014	2140	370	-	2210	440	860	790	265	250
	75	280S/	4	1450	1560	300	250	250	986	523	500	4 x 29	2160	2140	370	-	2210	440	860	790	265	250
	90	280S/	4	1450	1630	300	250	250	986	523	500	4 x 29	2160	2140	370	-	2210	440	860	790	265	250
	110	315 S/	4	1450	1690	300	250	250	1015	523	500	4 x 29	2352	2140	370	-	2210	440	860	790	265	250
	132	315 S/	4	1450	1835	300	250	250	1015	523	500	4 x 29	2352	2140	370	-	2210	440	860	790	265	250
	160	315 S/	4	1450	1835	300	250	250	1015	523	500	4 x 29	2422	2140	370	-	2210	440	860	790	265	250
	185	315 S/	4	1450	1820	300	250	250	1015	523	500	4 x 29	2453	2140	370	-	2210	440	860	790	265	250
250/500	110	315 S/	4	1450	1780	300	250	250	1040	548	560	4 x 29	2352	2140	370	-	2210	440	860	790	285	250
	132	315 S/	4	1450	1920	300	250	250	1040	548	560	4 x 29	2352	2140	370	-	2210	440	860	790	285	250
	160	315 S/	4	1450	1920	300	250	250	1040	548	560	4 x 29	2400	2140	370	-	2210	440	860	790	285	250
	185	315 S/	4	1450	1995	300	250	250	1040	548	560	4 x 29	2400	2140	370	-	2210	440	860	790	285	250
	200	315B	4	1450	2050	300	250	250	1120	612	560	6 x 22	2610	2150	200	875	2235	285	760	710	285	250
	250	355M/	4	1450	2800	300	250	250	1200	612	560	6 x 29	3040	2269	275	860	2344	350	800	750	285	250
	315	355M/	4	1450	3000	300	250	250	1200	612	560	6 x 29	3040	2269	275	860	2344	350	800	750	285	250
300/300	22	180L	4	1450	920	300	300	225	780	573	355	4 x 29	1700	2140	370	-	2170	400	860	790	330	250
	30	200L	4	1450	970	300	300	225	808	573	355	4 x 29	1735	2140	370	-	2170	400	860	790	330	250
	37	225S	4	1450	1020	300	300	225	833	573	355	4 x 29	1835	2140	370	-	2170	400	860	790	330	250
	45	225M	4	1450	1060	300	300	225	833	573	355	4 x 29	1835	2140	370	-	2170	400	860	790	330	250
	55	250M	4	1450	1090	300	300	225	833	573	355	4 x 29	1854	2140	370	-	2170	400	860	790	330	250
300/400	75	280S/	4	1450	1540	350	300	300	1072	662	400	4 x 19	2250	1960	300	-	2082	422	900	840	330	250
	90	280S/	4	1450	1630	350	300	300	1072	662	400	4 x 19	2305	1960	300	-	2082	422	900	840	330	250
	110	315 S/	4	1450	1700	350	300	300	1127	662	400	6 x 29	2400	2108	200	854	2235	330	900	840	330	250
	132	315 S/	4	1450	1776	350	300	300	1127	662	400	6 x 29	2400	2108	200	854	2235	330	900	840	330	250
	160	315 S/	4	1450	1833	350	300	300	1127	662	400	6 x 29	2472	2108	200	854	2235	330	900	840	330	250
300/450	110	315 S/	4	1450	1584	350	300	300	1127	662	560	4 x 29	2397	2104	200	-	2234	330	900	840	310	250
	132	315 S/	4	1450	1720	350	300	300	1127	662	560	4 x 29	2397	2104	200	-	2234	330	900	840	310	250
	160	315 S/	4	1450	1750	350	300	300	1127	662	560	4 x 29	2475	2104	200	-	2234	330	900	840	310	250
	185	315 S/	4	1450	1900	350	300	300	1154	662	560	4 x 29	2445	2104	200	-	2234	330	900	840	310	250
	200	315B	4	1450	2100	350	300	300	1182	662	560	4 x 29	2650	2200	200	-	2330	330	900	840	310	250
	250	355M/	4	1450	2517	350	300	300	1260	705	560	6 x 29	2795	2500	250	1000	2603	353	850	790	310	250

Norm pumps

Wilo-VeroNorm-NPG



Dimensions, weights Wilo-VeroNorm-NPG

Dimensions, weights – Complete installation on baseplate with motor (continued)

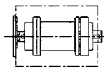
NPG...	Motor data				Weight [kg]	D _{NA} (suction side)	D _{NR} (pressure side)															 (Dimensions with spacer)				
	Motor performance [kW]	Motor size [-]	Pole [No.]	Speed [rpm]				a	H	H1	H2	S4	I	L1	L2	L3	L4	S1	B2	B3	C	E				
																							[mm]			
300/500	200	315B	4	1450	2900	350	300	300	1200	730	600	6 x 29	2990	2350	300	875	2460	410	860	810	330	250				
	250	355M/	4	1450	3100	350	300	300	1285	730	600	6 x 29	2890	2500	300	950	2610	410	860	810	330	250				
	300	355LB	4	1450	3100	350	300	300	1285	730	600	6 x 29	2940	2500	300	950	2610	410	860	810	330	250				
	315	355M/	4	1450	3200	350	300	300	1285	730	600	6 x 29	2890	2500	300	950	2610	410	860	810	330	250				
	355	315D	4	1450	3300	350	300	300	1285	730	600	6 x 29	3250	2600	300	1000	2710	410	860	810	330	250				
	400	315E	4	1450	3400	350	300	300	1400	730	600	6 x 29	3250	2600	300	1000	2710	410	860	810	330	250				
	450	355C	4	1450	3700	350	300	300	1400	730	600	6 x 29	3495	3100	300	1250	3210	410	860	810	330	250				
350/350	45	225M	4	1450	1200	350	350	250	1160	687	500	4 x 29	2100	1990	300	-	2025	335	860	810	390	250				
	55	250M	4	1450	1300	350	350	250	1110	687	500	4 x 29	2170	2000	300	-	2035	335	860	810	390	250				
	75	280S	4	1450	1405	350	350	250	1155	687	500	4 x 29	2150	2150	300	-	2185	335	860	810	390	250				
	90	280M	4	1450	1450	350	350	250	1155	687	500	4 x 29	2180	2150	300	-	2185	335	860	810	390	250				
400/500	132	315S/	6	990	2300	450	400	400	1087	910	600	6 x 30	3076	2700	250	1100	2980	430	1160	1100	420	300				
	160	315B	6	990	2800	450	400	400	1260	910	600	6 x 30	3190	2700	250	1100	2980	430	1160	1100	420	300				
	185	355 L	6	990	3000	450	400	400	1400	910	600	6 x 30	3300	2700	250	1100	2980	430	1160	1100	420	300				
	200	355 M	6	990	3300	450	400	400	1550	910	600	6 x 30	3300	2700	250	1100	2680	430	1160	1100	420	300				
400/650	160	355M/	6	990	3530	450	400	350	1590	910	760	6 x 30	3015	2800	250	1150	2930	380	1160	1100	410	300				
	185	355M/	6	990	3600	450	400	350	1590	910	760	6 x 30	3015	2800	250	1150	2930	380	1160	1100	410	300				
	200	355M/	6	990	3770	450	400	350	1590	910	760	6 x 30	3015	2800	250	1150	2930	380	1160	1100	410	300				
	250	355M/	6	990	3900	450	400	350	1590	910	760	6 x 30	3015	2800	250	1150	2930	380	1160	1100	410	300				
	315	355M/	6	990	4000	450	400	350	1590	910	760	6 x 30	3015	2800	250	1150	2930	380	1160	1100	410	300				
	355	355C	6	990	4700	450	400	350	1500	910	760	6 x 30	3630	3180	250	1340	2930	380	1160	1100	410	300				
	400	355D	6	990	4950	450	400	350	1500	910	760	6 x 30	3630	3180	250	1340	2930	380	1160	1100	410	300				
500/500	55	280M	6	990	2450	500	500	400	1330	930	500	6 x 30	2640	2450	225	1000	2555	330	1160	1100	490	300				
	75	315S	6	990	2600	500	500	400	1412	930	500	6 x 30	2760	2550	225	1050	2655	330	1160	1100	490	300				
	90	315M	6	990	2650	500	500	400	1412	930	500	6 x 30	2760	2550	225	1050	2655	330	1160	1100	490	300				
	110	315M	6	990	2800	500	500	400	1450	930	500	6 x 30	2960	2600	225	1075	2705	330	1160	1100	490	300				

Pumps with axially split housing

Single pumps (heating, air-conditioning, cooling and industry)

Series overview

Series: Wilo-SCP



> Design

Low-pressure centrifugal pump with axially split housing mounted on the baseplate

> Application

- Pumping heating water in accordance with VDI 2035 water-glycol mixtures, cooling/cold water and secondary hot water
- Applications in municipal water supply, irrigation, building services, general industry, power stations, etc.

Series overview

Series: Wilo-SCP

> Special features/product benefits

- Easy maintenance (without removing the delivery or suction pipes)
- Low NPSH (due to the double suction impeller)
- Better life time (distributed load on the bearings)
- Possibility of both directions of rotation (Clockwise or counter clockwise)
- Sealed for life bearings

> More information

	Page
• Planning guide	6
• Technical data	114
• Series description	108
• Pump curves.....	116
• Terminal diagrams, motor data ...	133
• Dimensions, weights	135
• Switchgears and control devices ...	160

Pumps with axially split housing

Single pumps (heating, air-conditioning, cooling and industry)

Series description Wilo-SCP



Design

Pump with axially split housing mounted on a baseplate

Application

- Pumping heating water in accordance with VDI 2035 water/glycol mixtures, cooling/cold water and secondary hot water
- Applications in municipal water supply, irrigation, building services, general industry, power stations, etc.

Scope of delivery

- Pump
- Installation and operating instructions

Type key

Example	SCP 200/250HA-110/4
SCP	Pump with axially split housing
200	Nominal diameter of pressure port
250	Nominal width of impeller
HA	Hydraulics type A
HB	Hydraulics type B
HS	Single suction impeller
DS	Two-stage pump
DV	Double volute
110	Rated motor power P_2 [kW]
4	4-pole pump

Materials

- Pump housing: EN-GJL-250
- Impeller: G-CuSn5 ZnPb
- Shaft: X12Cr13

Description/design

- Centrifugal pump with axially split case, available in single-stage and two-stage design.
- Delivered as complete unit (pump with coupling, coupling protection, motor and baseplate) or without motor or only pump hydraulics
- Shaft sealing with mechanical shaft seal or stuffing box
- 2-, 4- and 6-pole motors; Standard version 50 Hz

Options

- Other motor versions on request
- Higher volume flow up to 17 000 m³/h as special version
- Special motor (6000V, 10 000 V etc.)
- Special construction
 - Impeller: Bronze, grey cast iron, stainless steel
 - Housing: Grey cast iron, spheroidal cast iron
- Cyclone separator (for flushing the seal)

Pump with free shaft end

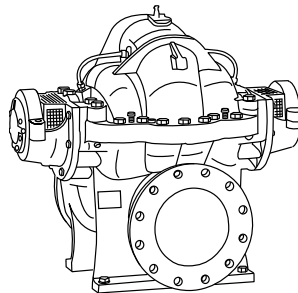

Pump on baseplate with coupling, without motor

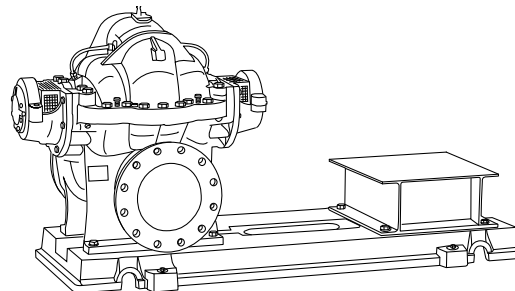

Complete installation on baseplate with motor

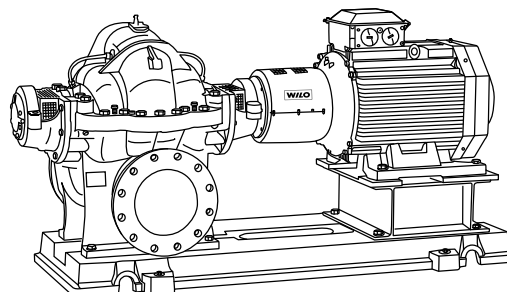

Pumps with axially split housing

Single pumps (heating, air-conditioning, cooling and industry)



Series description Wilo-SCP

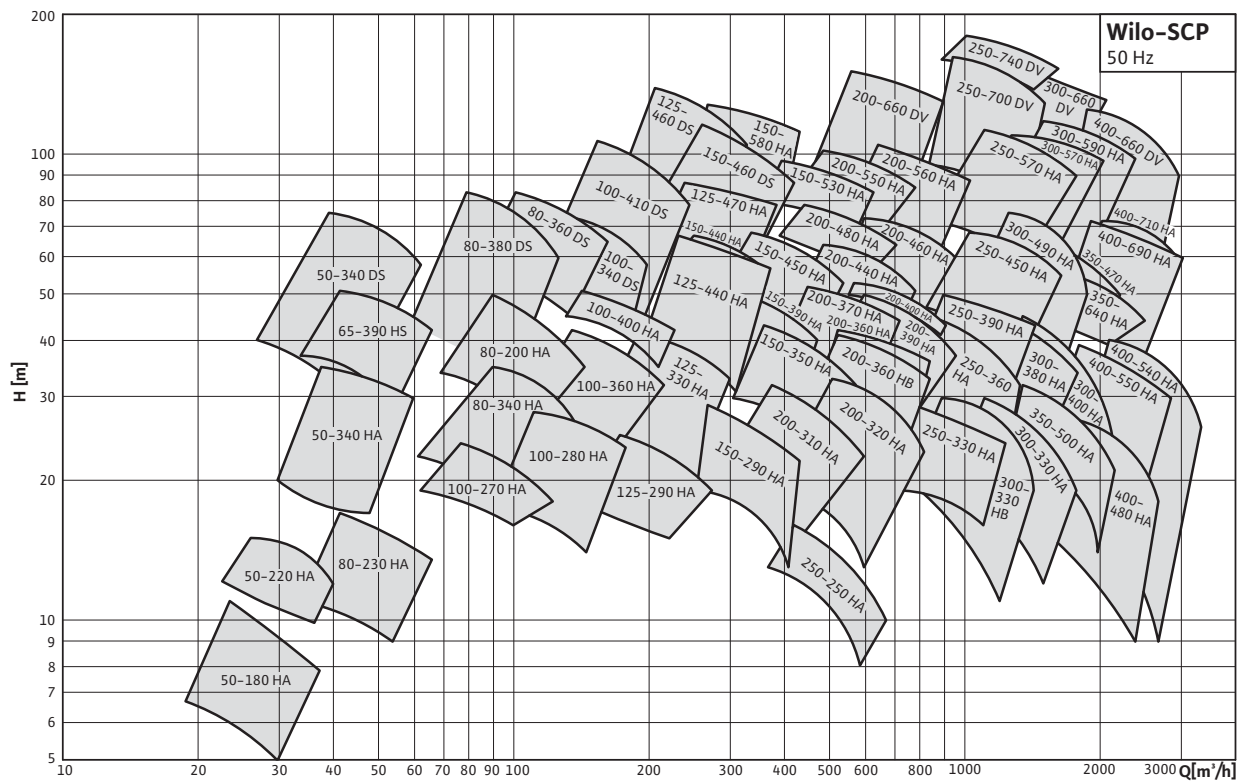

Pumps with axially split housing

Pumps with axially split housing

Single pumps (heating, air-conditioning, cooling and industry)

Series description Wilo-SCP

Section drawing: Single-stage pump with mechanical seal

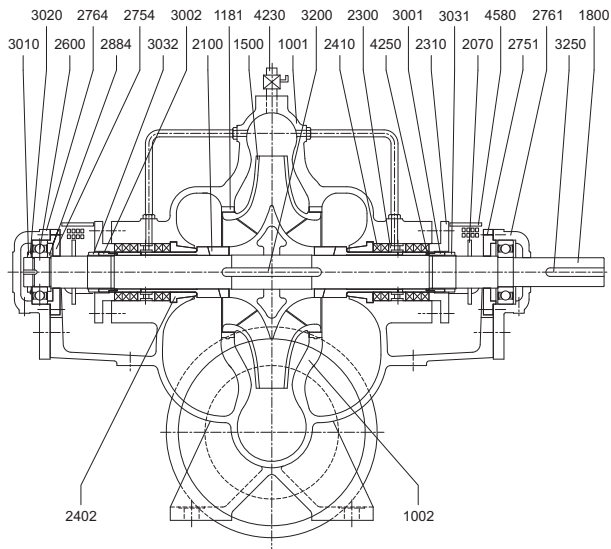

1001	Housing, upper part
1002	Housing, lower part
1181	Stationary wear ring
1500	Impeller
1800	Shaft
2070	Water spray ring
2100	Shaft sleeve
2402	Counter ring
2420	Mechanical seal (relieving)
2421	Cover for mechanical seal
2600	Grooved ball bearing
2751	Bearing housing, outside (drive side)
2754	Bearing housing, outside (non-drive side)
2761	Bearing housing (drive side)
2764	Bearing housing (non-drive side)
2884	Support ring
3001	Support nut (left)
3002	Support nut (right)
3010	Counter nut
3020	Safety disk
3031	Counter nut for shaft sleeve (left)
3032	Counter nut for shaft sleeve (right)
3200	Key for impeller
3250	Key for coupling
4230	Ventilation cock
4250	O-ring
4580	Protection cover

Pumps with axially split housing

Single pumps (heating, air-conditioning, cooling and industry)



Series description Wilo-SCP

Section drawing: Single-stage pump with stuffing box

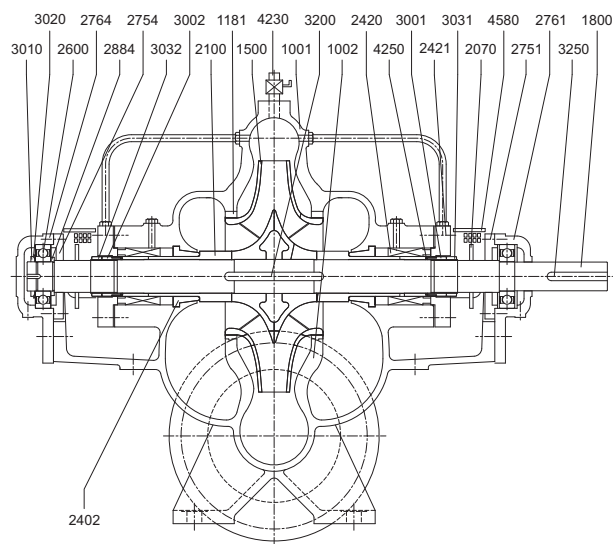

1001	Housing, upper part
1002	Housing, lower part
1181	Stationary wear ring
1500	Impeller
1800	Shaft
2070	Water spray ring
2100	Shaft sleeve
2300	Lantern ring
2310	Gland
2402	Counter ring
2410	Stuffing box
2600	Grooved ball bearing
2751	Bearing housing, outside (drive side)
2754	Bearing housing, outside (non-drive side)
2761	Bearing housing (drive side)
2764	Bearing housing (non-drive side)
2884	Support ring
3001	Support nut (left)
3002	Support nut (right)
3010	Counter nut
3020	Safety disk
3031	Counter nut for shaft sleeve (left)
3032	Counter nut for shaft sleeve (right)
3200	Key for impeller
3250	Key for coupling
4230	Ventilation cock
4250	O-ring
4580	Protection cover

Pumps with axially split housing

Single pumps (heating, air-conditioning, cooling and industry)

Series description Wilo-SCP

Section drawing: Two-stage pump with mechanical seal

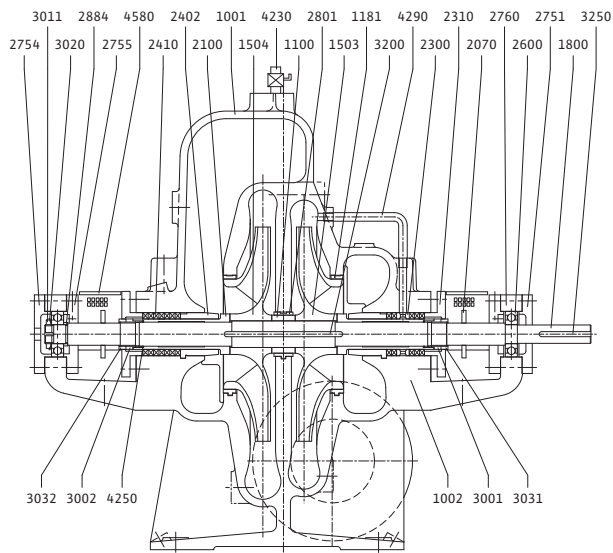

1001	Housing, upper part
1002	Housing, lower part
1100	Spacer ring
1181	Stationary wear ring
1503	Impeller, first stage (right)
1504	Impeller, second stage (left)
1800	Shaft
2070	Water spray ring
2100	Shaft sleeve
2311	Cover for mechanical seal
2402	Counter ring
2411	Mechanical seal
2600	Grooved ball bearing
2751	Bearing housing, outside (drive side)
2754	Bearing housing, outside (non-drive side)
2755	Bearing housing, inside (drive and non-drive side)
2760	Bearing housing
2801	Intermediate bearing sleeve
2884	Support ring
3001	Support nut (left)
3002	Support nut (right)
3011	Counter nut
3020	Safety disk
3031	Counter nut for shaft sleeve (left)
3032	Counter nut for shaft sleeve (right)
3200	Key for impeller
3250	Key for coupling
4230	Ventilation cock
4250	O-ring
4290	Flushing pipe for mechanical seal
4580	Protection cover

Pumps with axially split housing

Single pumps (heating, air-conditioning, cooling and industry)



Series description Wilo-SCP

Section drawing: Two-stage pump with stuffing box packing

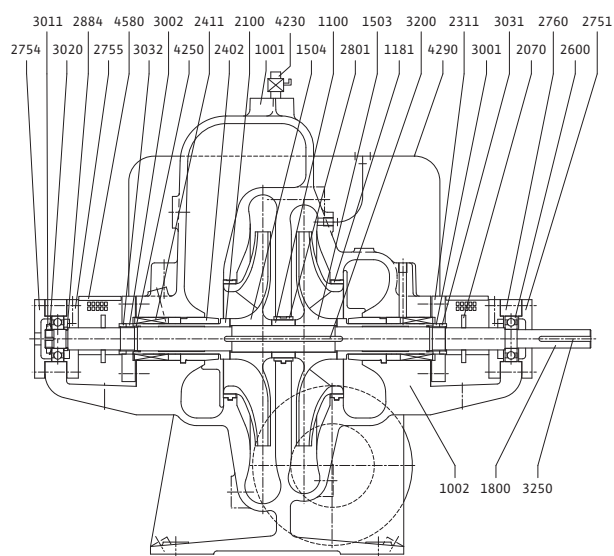

1001	Housing, upper part
1002	Housing, lower part
1100	Spacer ring
1181	Stationary wear ring
1503	Impeller, first stage (right)
1504	Impeller, second stage (left)
1800	Shaft
2070	Water spray ring
2100	Shaft sleeve
2300	Lantern ring
2310	Gland
2402	Counter ring
2410	Stuffing box
2600	Grooved ball bearing
2751	Bearing housing, outside (drive side)
2754	Bearing housing, outside (non-drive side)
2755	Bearing housing, inside (drive and non-drive side)
2760	Bearing housing
2801	Intermediate bearing sleeve
2884	Support ring
3001	Support nut (left)
3002	Support nut (right)
3011	Counter nut
3020	Safety disk
3031	Counter nut for shaft sleeve (left)
3032	Counter nut for shaft sleeve (right)
3200	Key for impeller
3250	Key for coupling
4230	Ventilation cock
4250	O-ring
4290	Water sealing pipe
4580	Protection cover

Pumps with axially split housing

Single pumps (heating, air-conditioning, cooling and industry)

Technical data Wilo-SCP	
Wilo- SCP	
Approved fluids (other fluids on request)	
Heating water (in accordance with VDI 2035)	•
Cooling and cold water	•
Water-glycol mixtures (for 20–40 vol.% glycol and fluid temperature ≤ 40 °C)	• (from 10 vol.% glycol: performance check required)
Permitted field of application	
Fluid temperature (mechanical seal) [°C]	-20 to +120
Fluid temperature (stuffing box) [°C]	to 105
Pipe connections	
Nominal connection diameters DN	on suction side: 50–200 (larger nominal diameters on request) on pressure side: 32–150 (larger nominal diameters on request)
Materials	
Pump housing	EN-GJL-250
Pump housing (special version)	spheroidal cast iron
Impeller (standard)	G-CuSn5ZnPb
Impeller (special version)	grey cast iron, stainless steel
Stationary wear rings	G-CuPb10Sn
Pump shaft	X12cr13
Pumpshaft (Special)	
Mechanical seal	Carbon/silicon carbide/EPDM
Other mechanical seals	stuffing box
Construction materials (American standard)	
Pump housing	A48 class 35
Pump housing (special version)	spheroidal cast iron
Impeller	B584 C83 600
Impeller (special version)	grey cast iron, stainless steel
Stationary wear rings	B584 C93 700
Pump shaft	A276 type 410
Mechanical seal	Carbon/silicon carbide/EPDM
Other mechanical seals	stuffing box
Motor/electronics	
Factory standard IEC motor	•
Protection class	IP 55
Insulation class	F
PTC thermistor sensor	•
Motor protection required onsite	– (to be provided for onsite installation)
Motor winding up to 3 kW	230 V Δ /400 V Y, 50 Hz

Pumps with axially split housing

Single pumps (heating, air-conditioning, cooling and industry)



Technical data Wilo-SCP

	Wilo- SCP
Motor winding from 4 kW	400 V Δ /690 V Y, 50 Hz
Other voltages/frequencies	Special version at additional charge
Speed of 6-pole motors [rpm]	980
Speed of 4-pole motors [rpm]	1480
Speed of 2-pole motors [rpm]	2980
Speed control	Wilo control devices, external frequency converter (at additional charge)

• = available, - = not available

Pumps with axially split housing

Single pumps (heating, air-conditioning, cooling and industry)

Pump curves Wilo-SCP

Wilo-SCP 50/180 HA

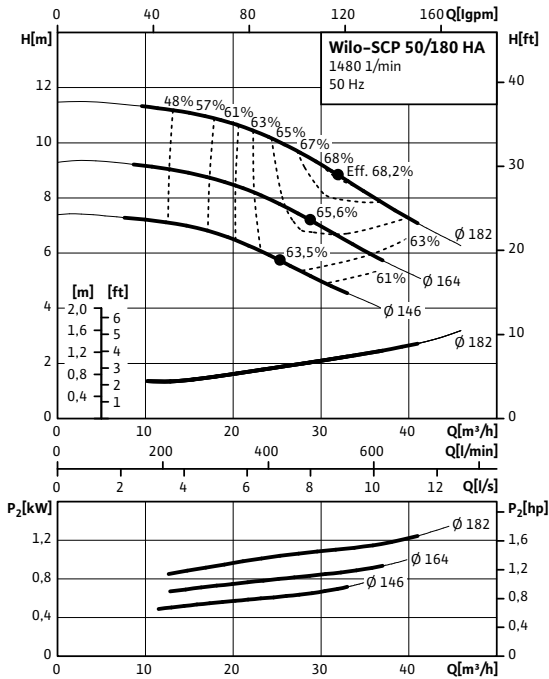

Wilo-SCP 50/220 HA

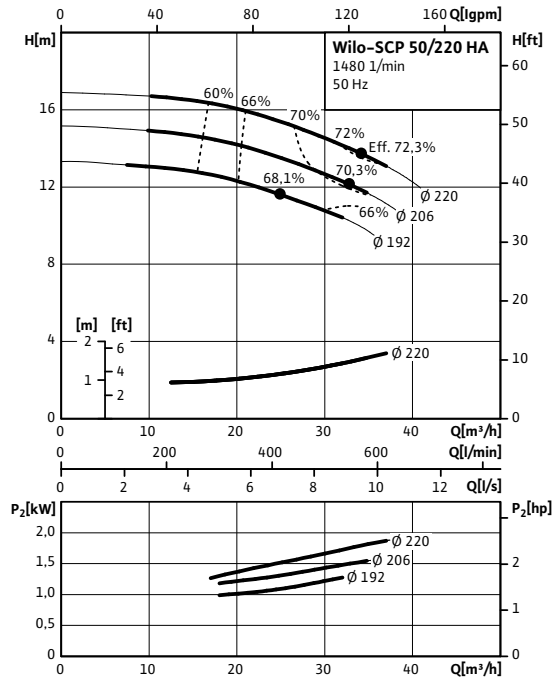

Wilo-SCP 50/340 HA

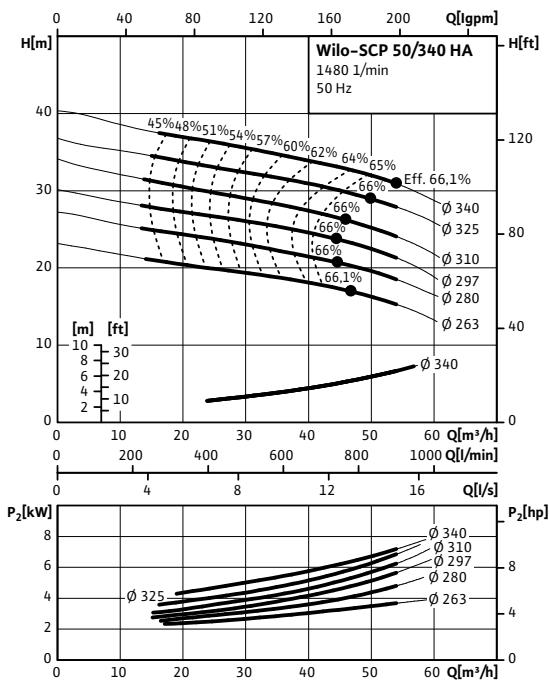

Wilo-SCP 50/340 DS

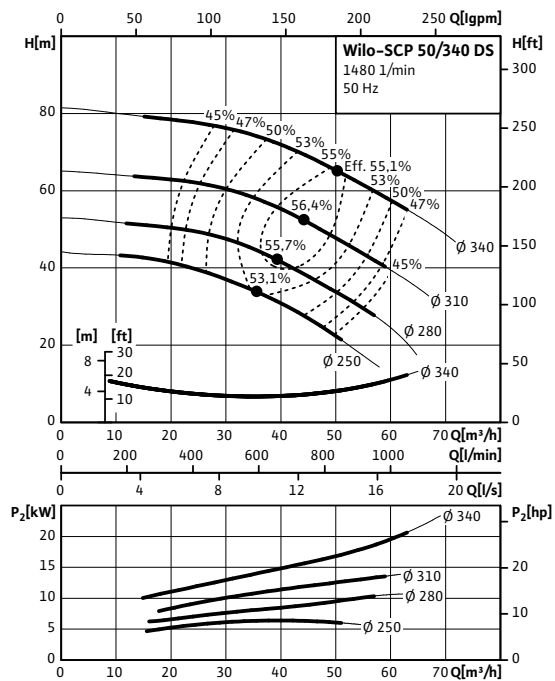

Pumps with axially split housing

Single pumps (heating, air-conditioning, cooling and industry)



Pump curves Wilo-SCP

Wilo-SCP 65/390 HS

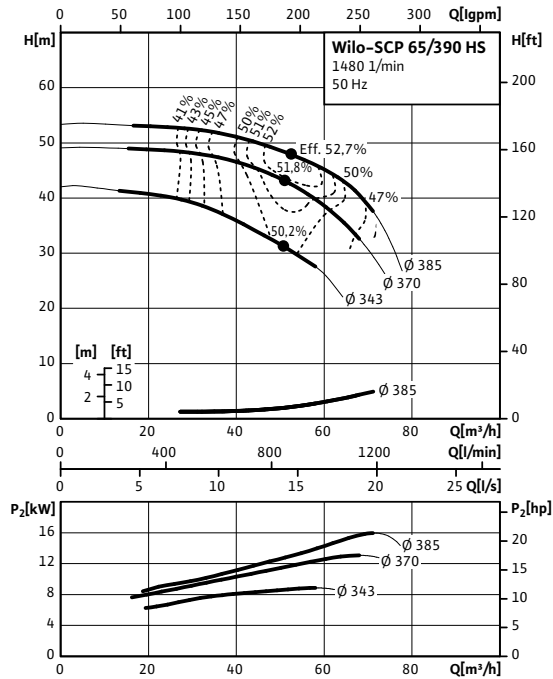

Wilo-SCP 80/200 HA

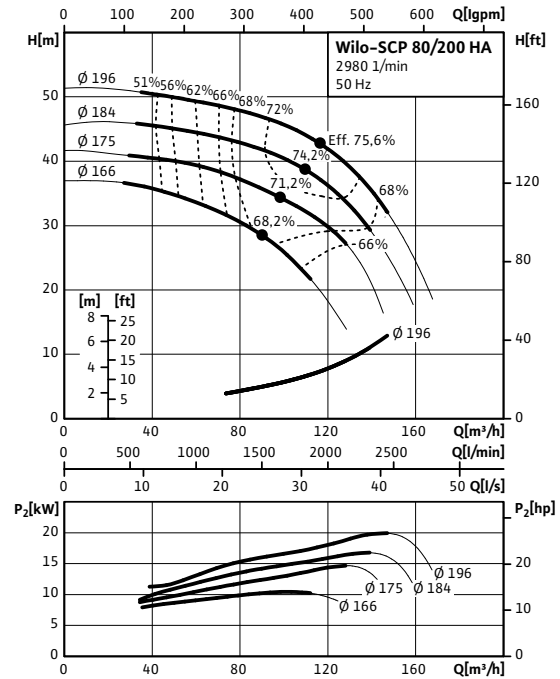

Wilo-SCP 80/230 HA

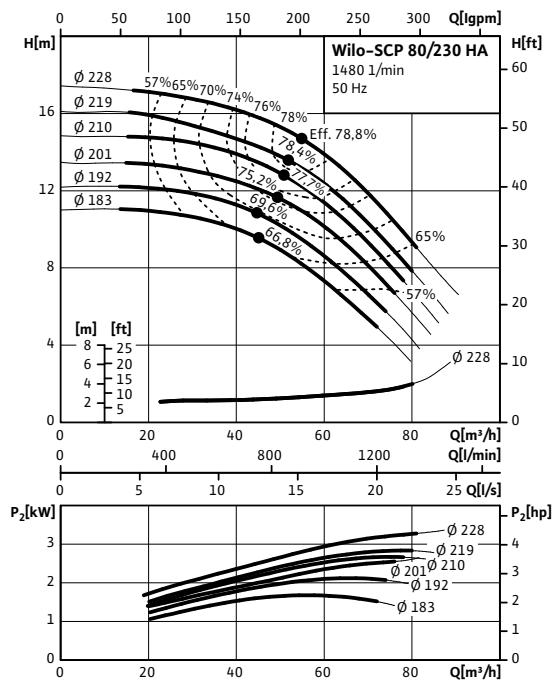

Wilo-SCP 80/340 HA

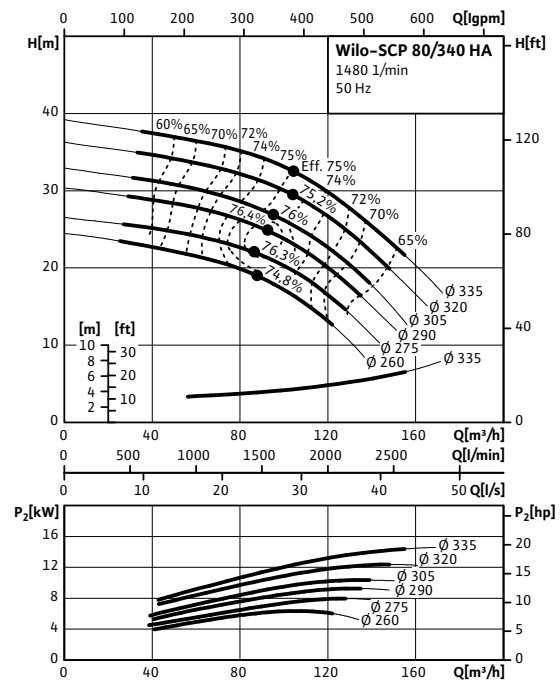

Pumps with axially split housing

Single pumps (heating, air-conditioning, cooling and industry)

Pump curves Wilo-SCP

Wilo-SCP 80/360 DS

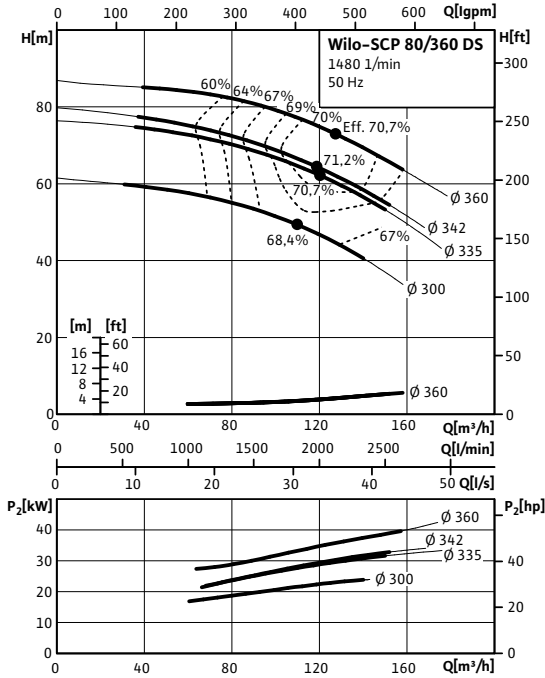

Wilo-SCP 80/380 DS

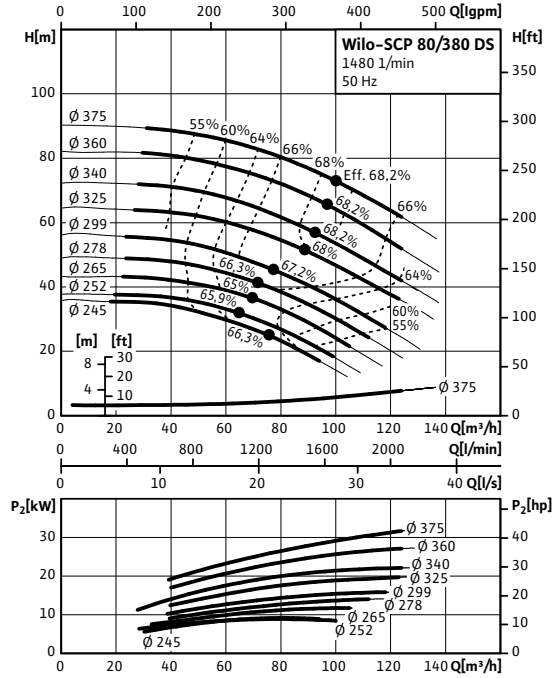

Wilo-SCP 100/270 HA

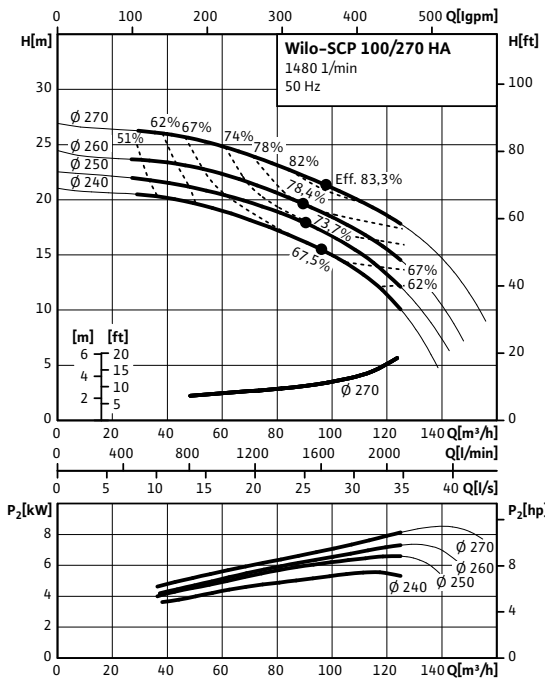

Wilo-SCP 100/280 HA

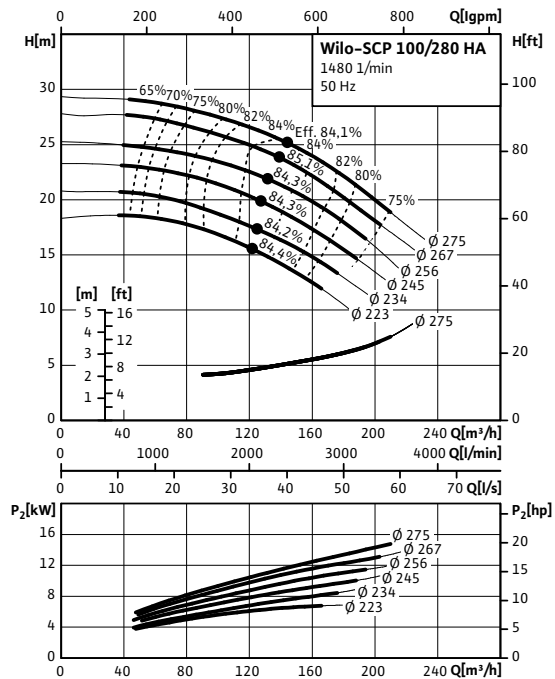

Pumps with axially split housing

Single pumps (heating, air-conditioning, cooling and industry)



Pump curves Wilo-SCP

Wilo-SCP 100/340 DS

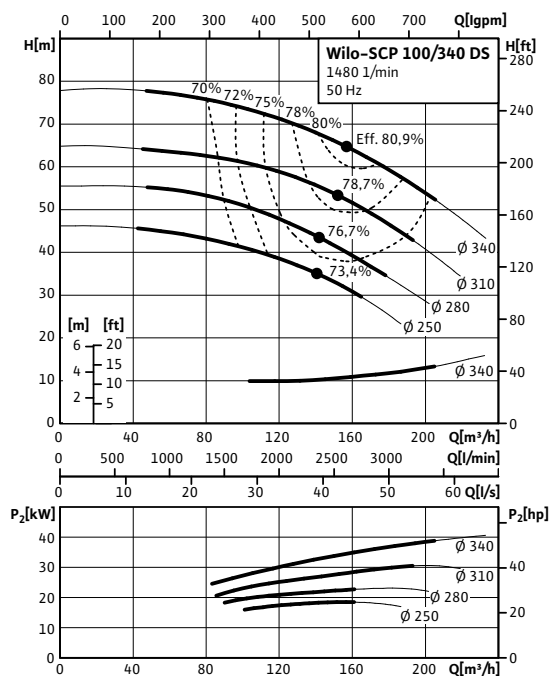

Wilo-SCP 100/360 HA

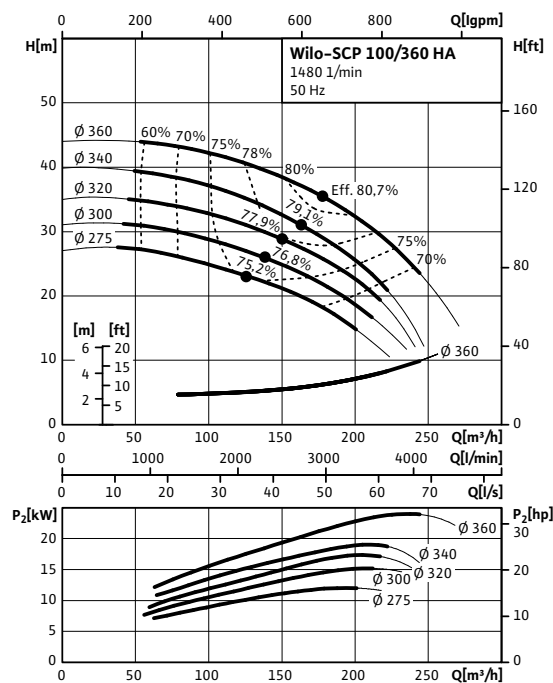

Wilo-SCP 100/400 HA

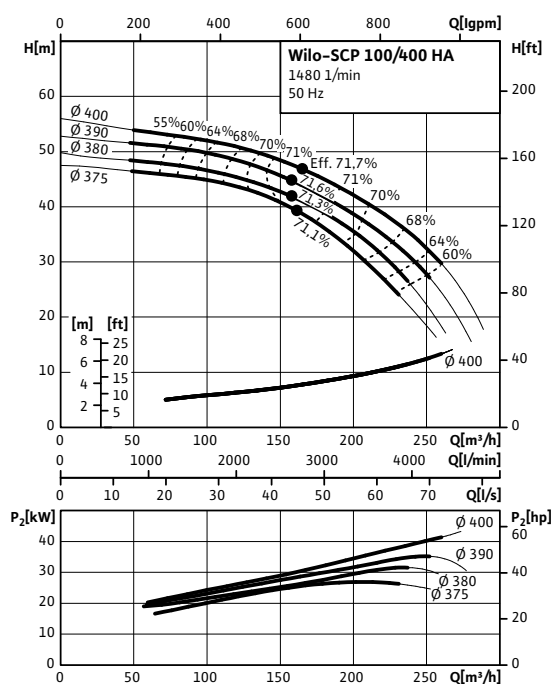

Wilo-SCP 100/410 DS

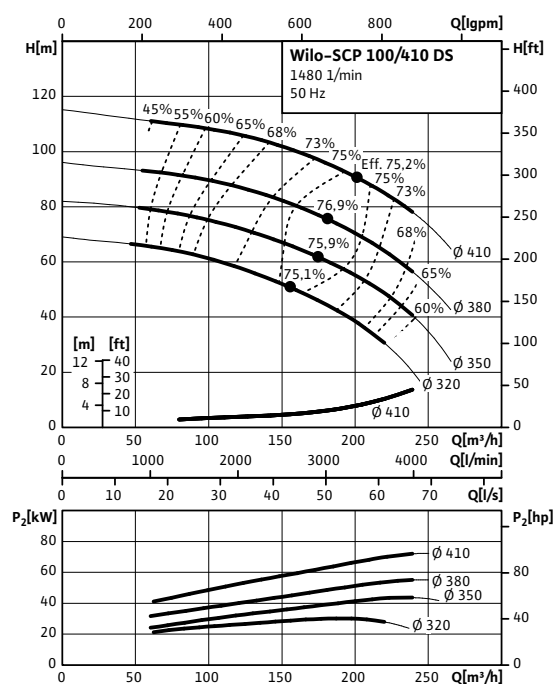

Pumps with axially split housing

Pumps with axially split housing

Single pumps (heating, air-conditioning, cooling and industry)

Pump curves Wilo-SCP

Wilo-SCP 125/290 HA

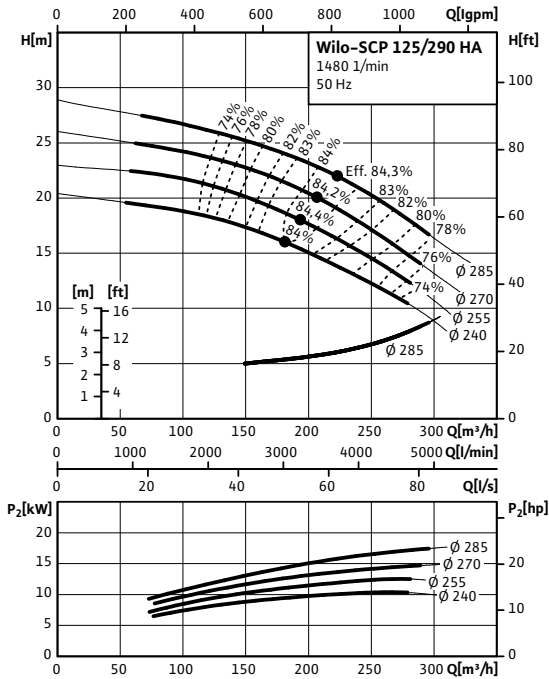

Wilo-SCP 125/330 HA

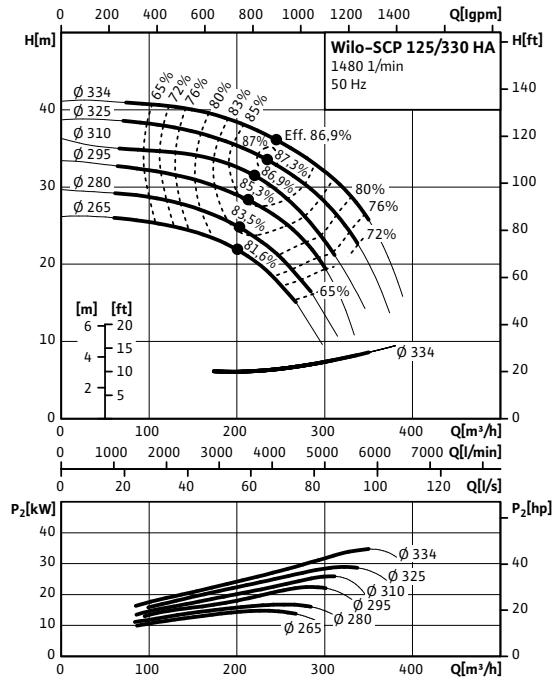

Wilo-SCP 125/440 HA

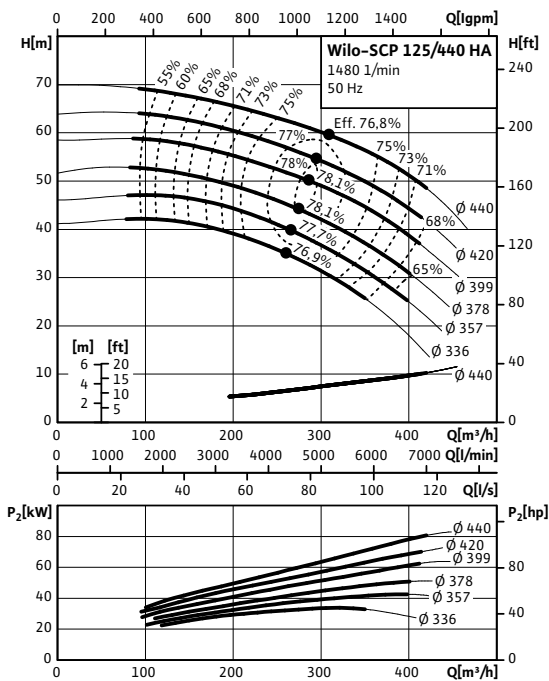

Wilo-SCP 125/460 DS

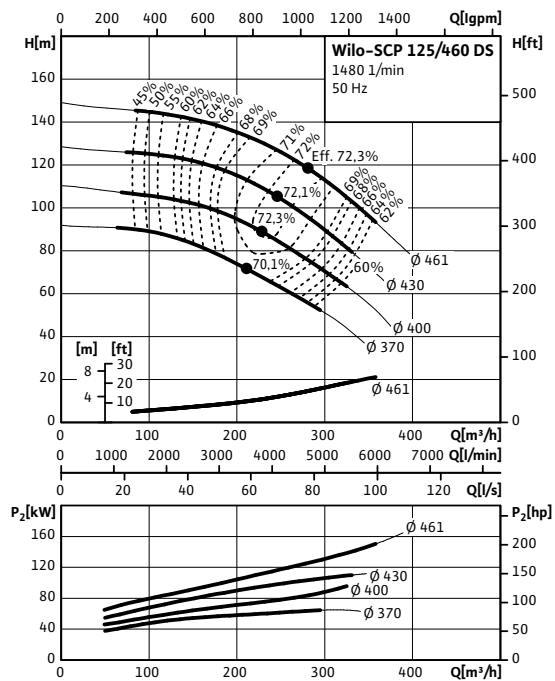

Pumps with axially split housing

Single pumps (heating, air-conditioning, cooling and industry)



Pump curves Wilo-SCP

Wilo-SCP 125/470 HA

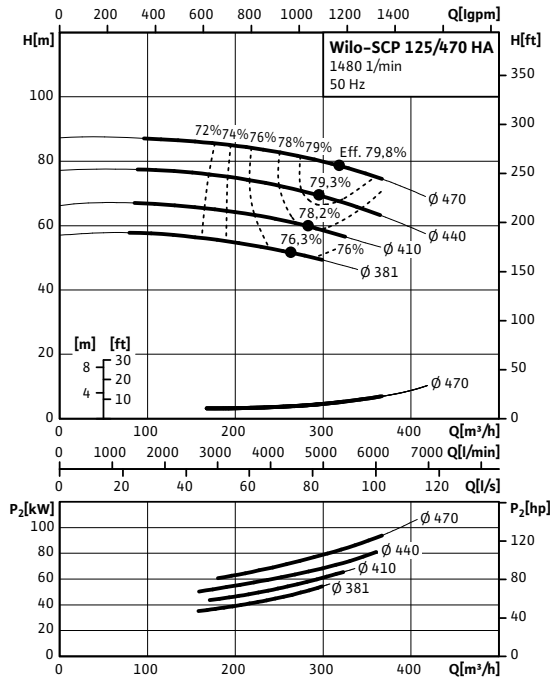

Wilo-SCP 150/290 HA

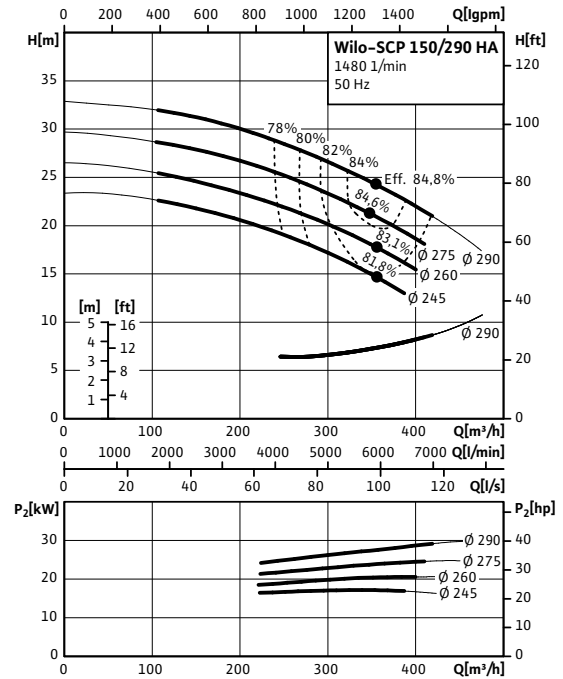

Wilo-SCP 150/350 HA

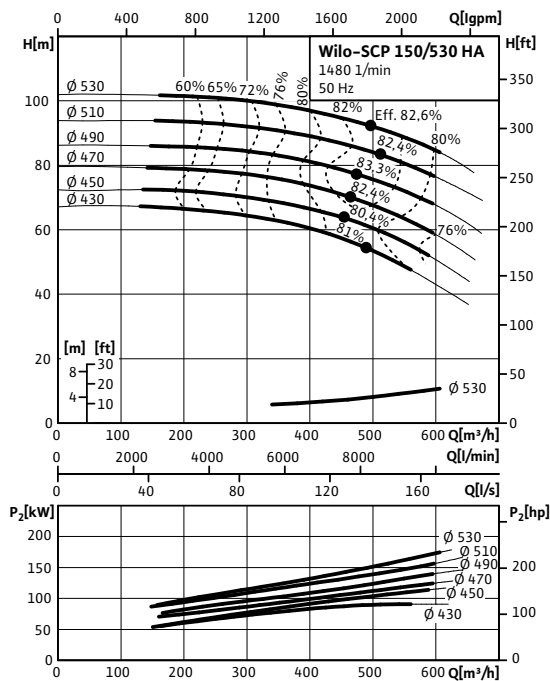

Wilo-SCP 150/390 HA

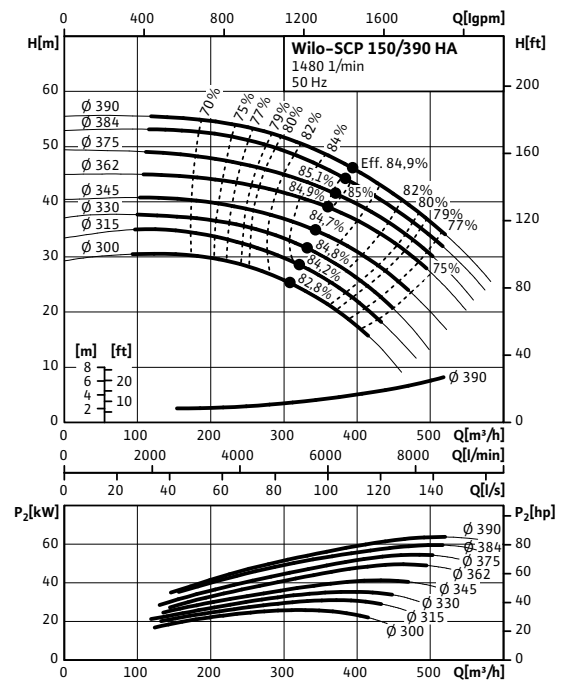

Pumps with axially split housing

Pumps with axially split housing

Single pumps (heating, air-conditioning, cooling and industry)

Pump curves Wilo-SCP

Wilo-SCP 150/440 HA

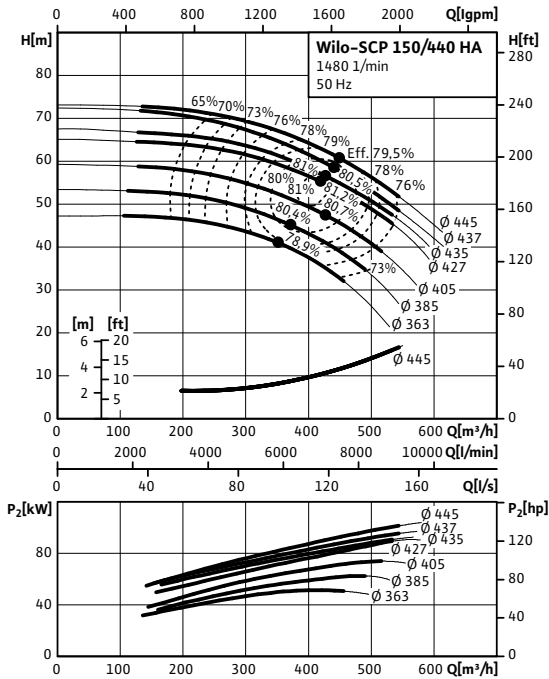

Wilo-SCP 150/450 HA

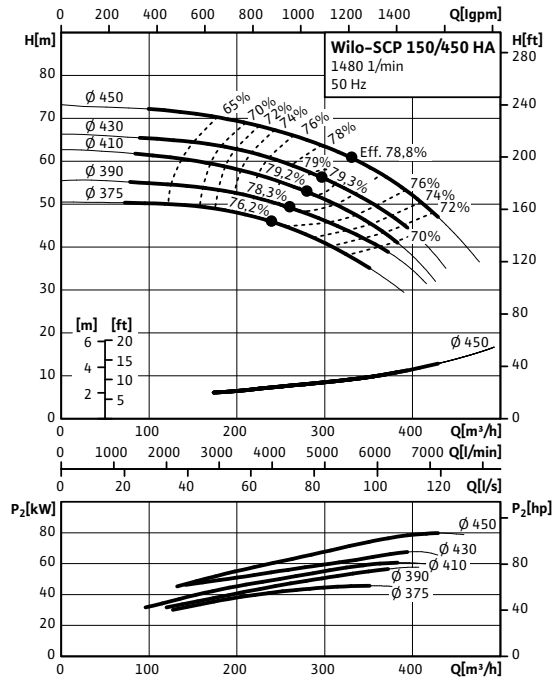

Wilo-SCP 150/460 DS

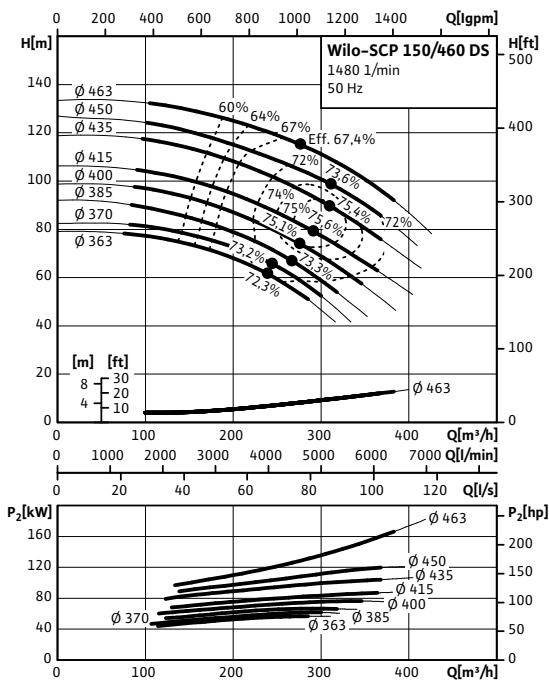

Wilo-SCP 150/530 HA

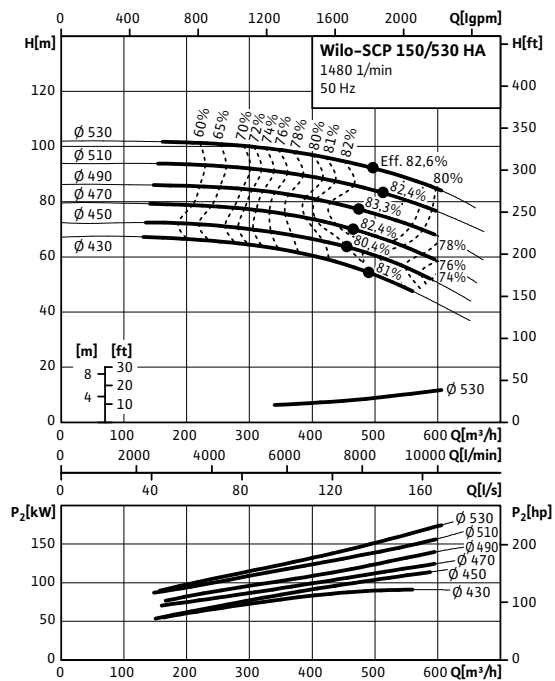

Pumps with axially split housing

Single pumps (heating, air-conditioning, cooling and industry)



Pump curves Wilo-SCP

Wilo-SCP 150/580 HA

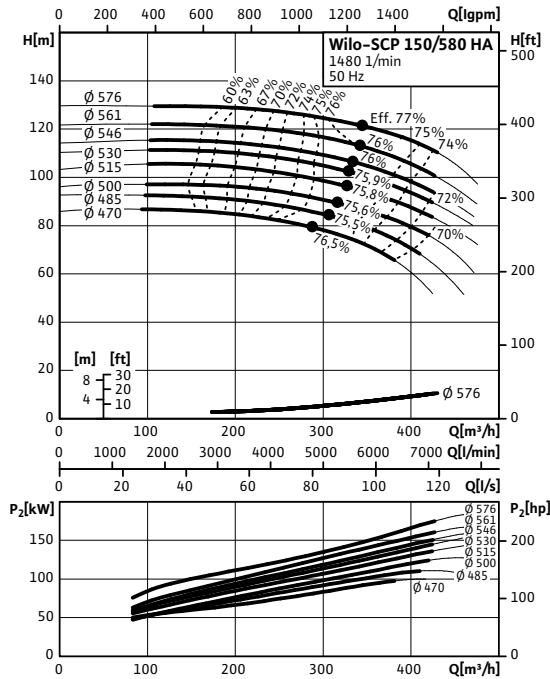

Wilo-SCP 200/310 HA

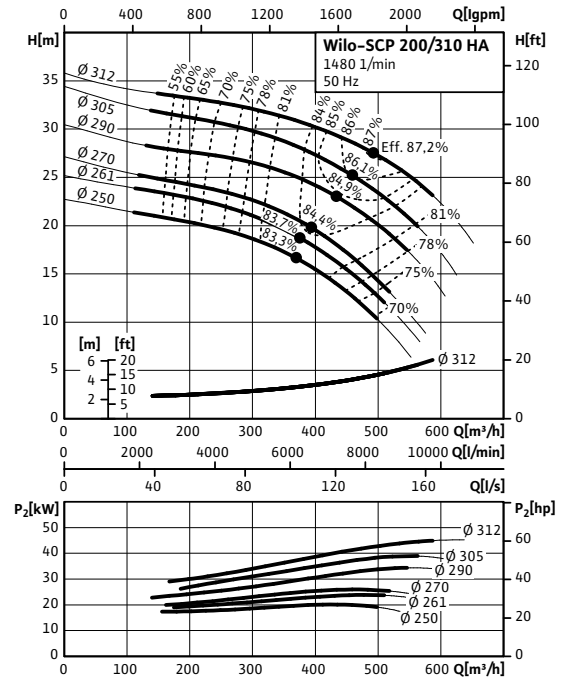

Wilo-SCP 200/320 HA

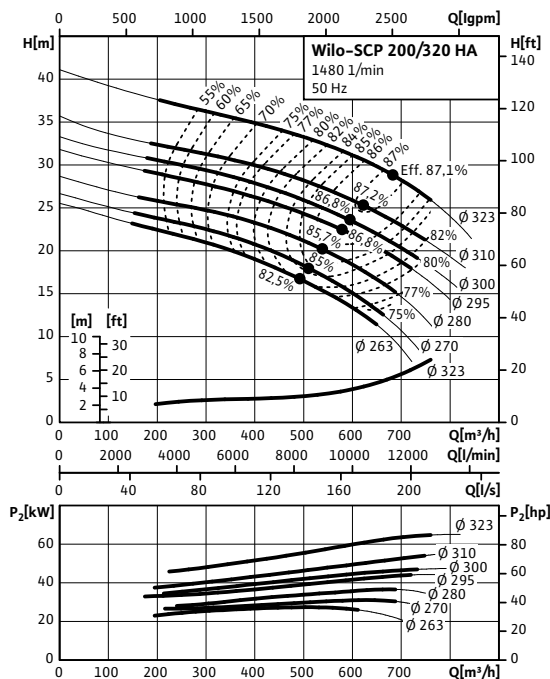

Wilo-SCP 200/360 HA

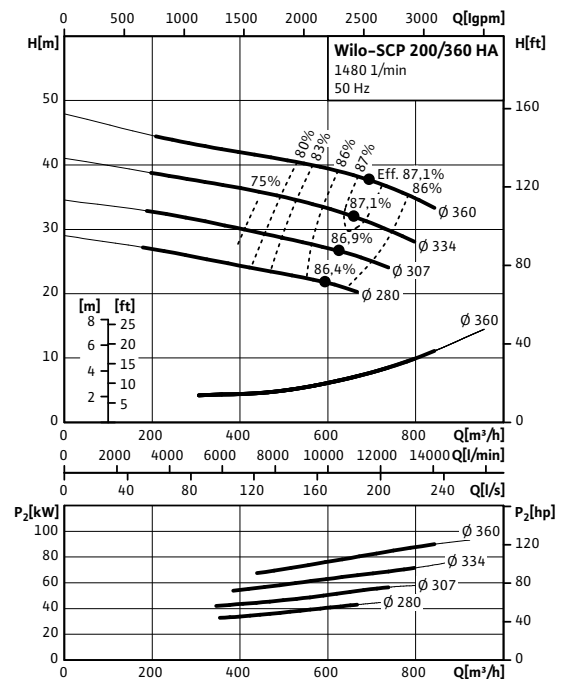

Pumps with axially split housing

Pumps with axially split housing

Single pumps (heating, air-conditioning, cooling and industry)

Pump curves Wilo-SCP

Wilo-SCP 200/360 HB

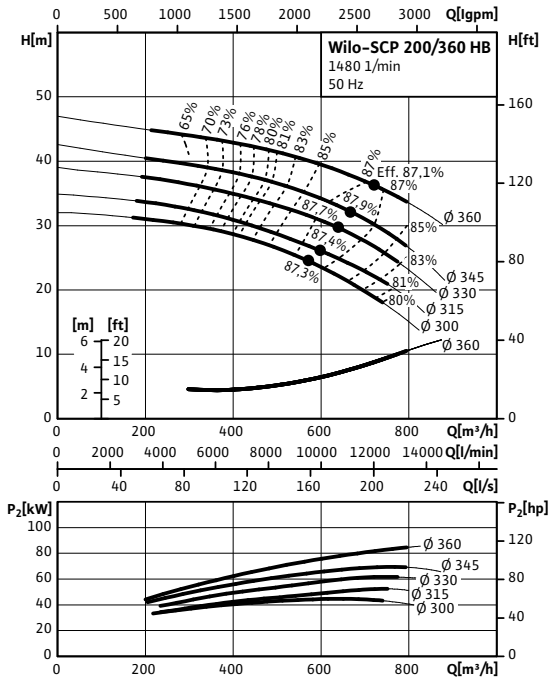

Wilo-SCP 200/370 HA

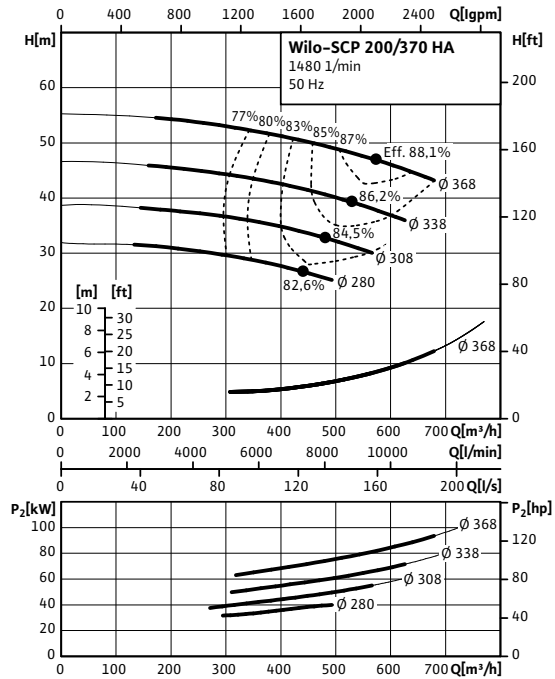

Wilo-SCP 200/390 HA

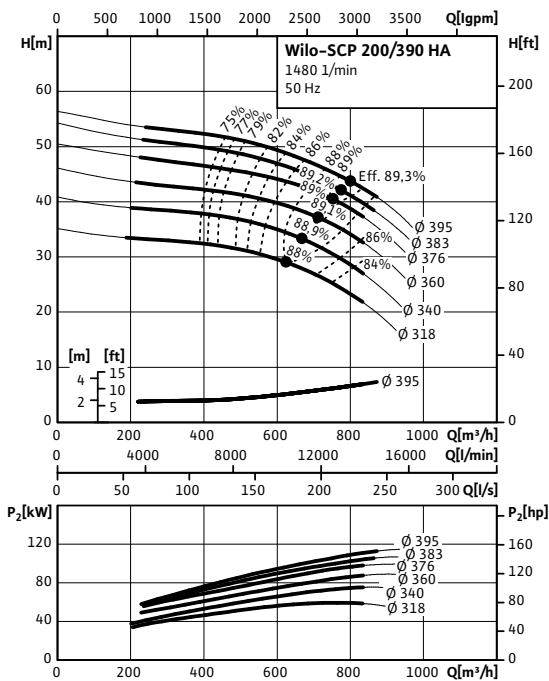

Wilo-SCP 200/400 HA

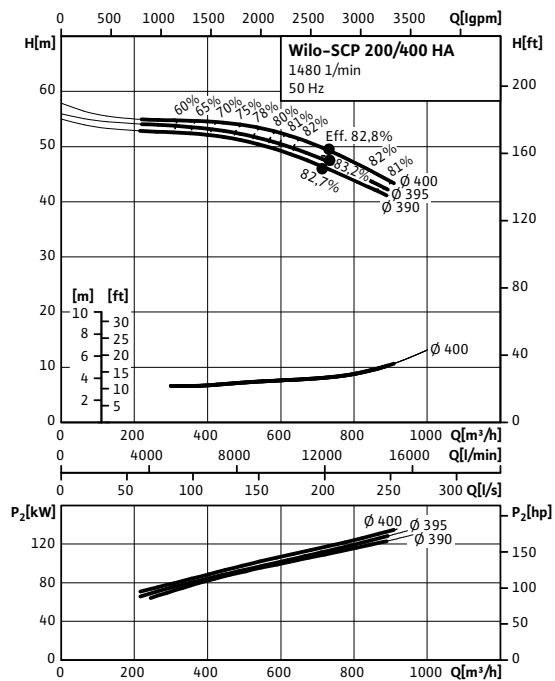

Pumps with axially split housing

Single pumps (heating, air-conditioning, cooling and industry)



Pump curves Wilo-SCP

Wilo-SCP 200/440 HA

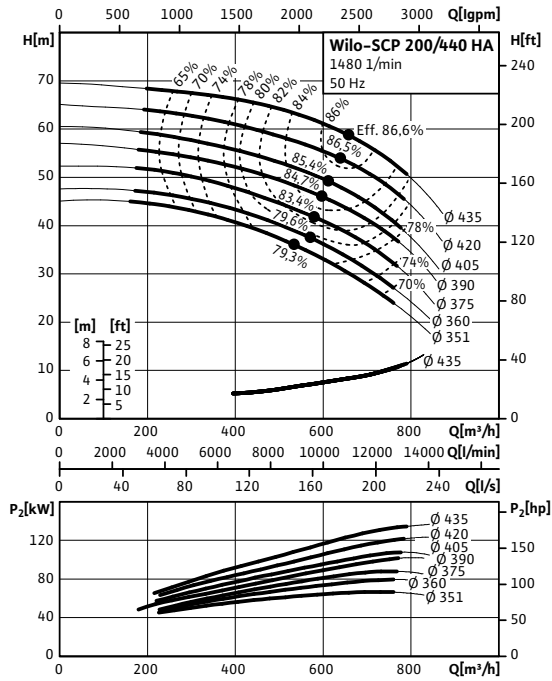

Wilo-SCP 200/460 HA

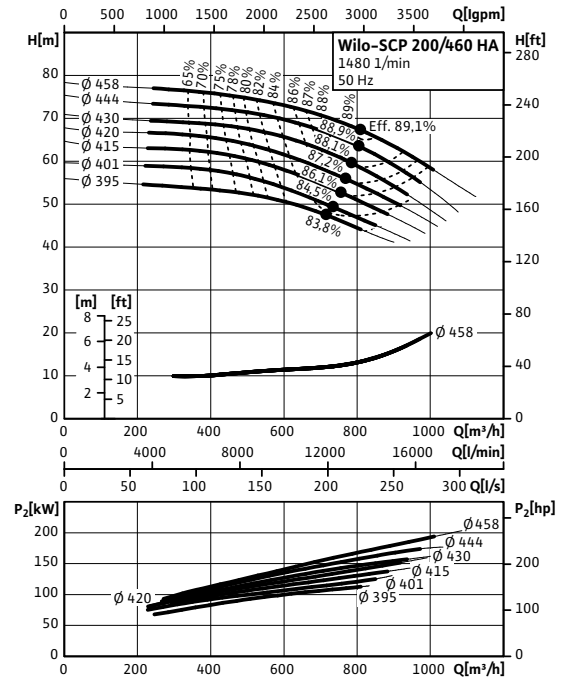

Wilo-SCP 200/480 HA

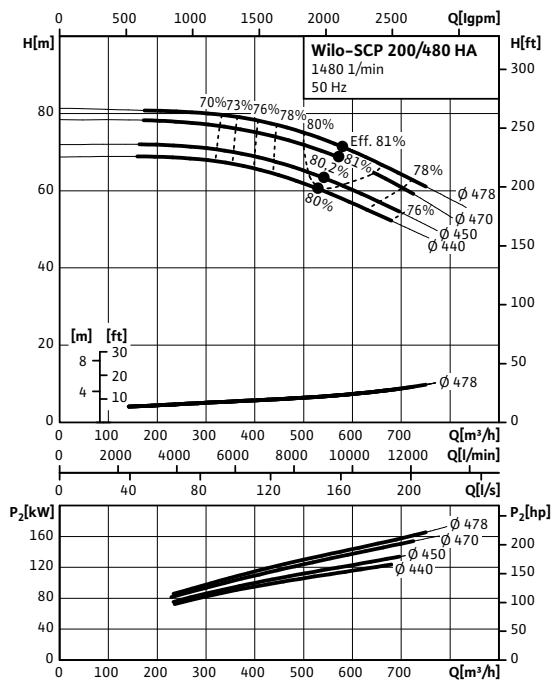

Wilo-SCP 200/560 HA

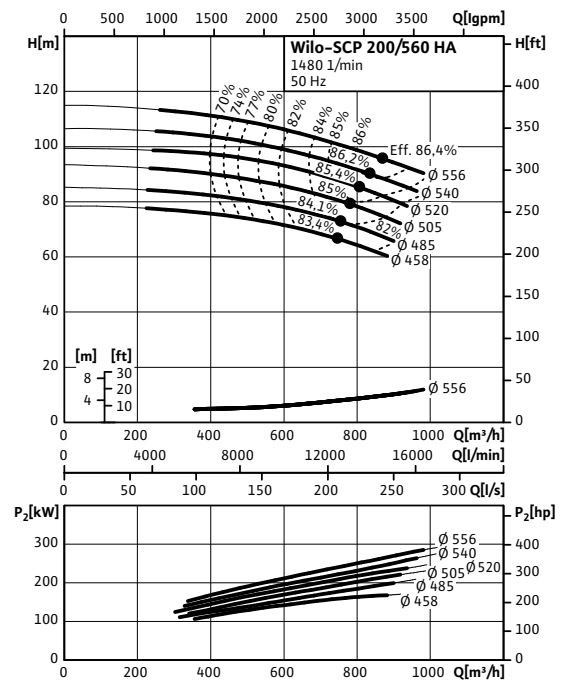

Pumps with axially split housing

Pumps with axially split housing

Single pumps (heating, air-conditioning, cooling and industry)

Pump curves Wilo-SCP

Wilo-SCP 200/550 HA

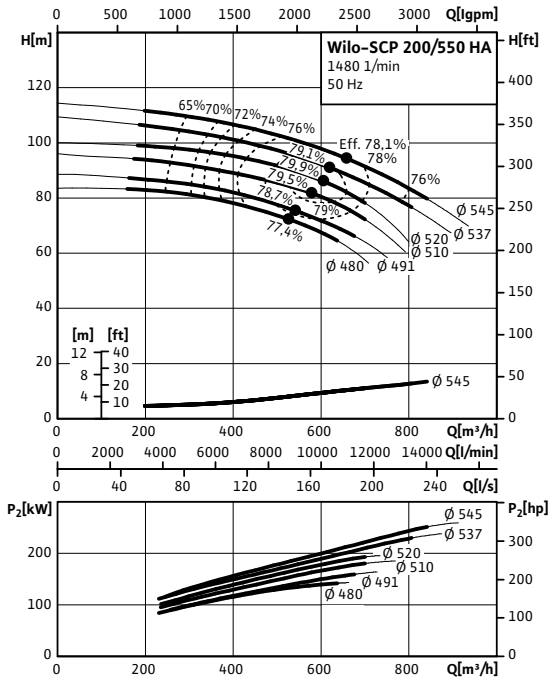

Wilo-SCP 200/660 DV

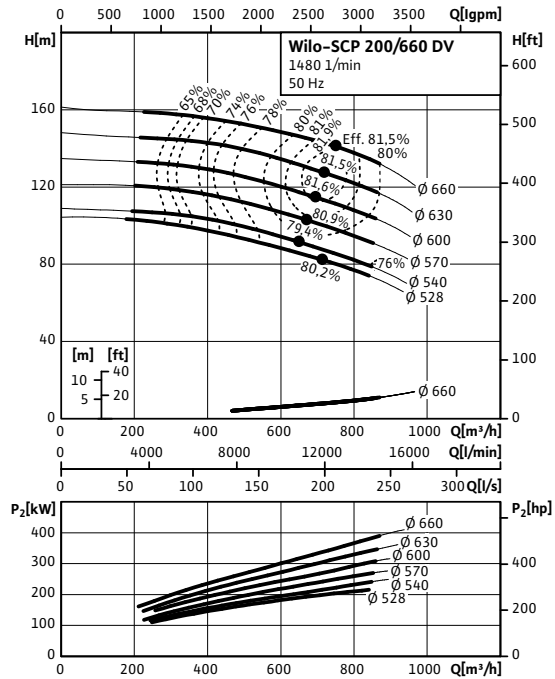

Wilo-SCP 250/250 HA

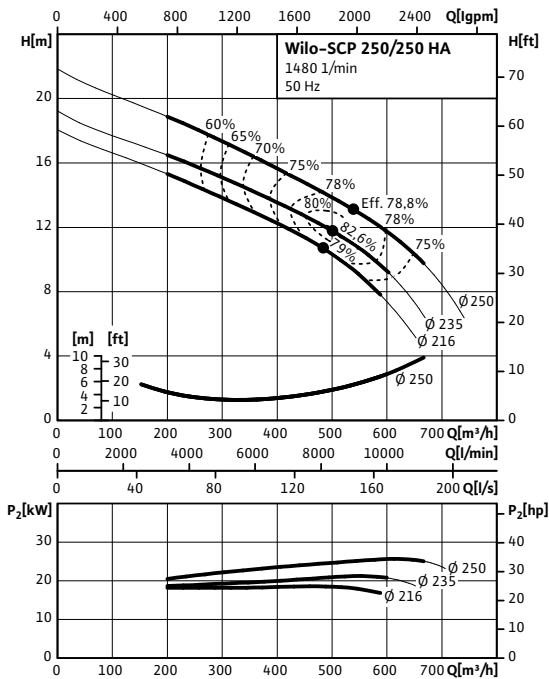

Wilo-SCP 250/330 HA

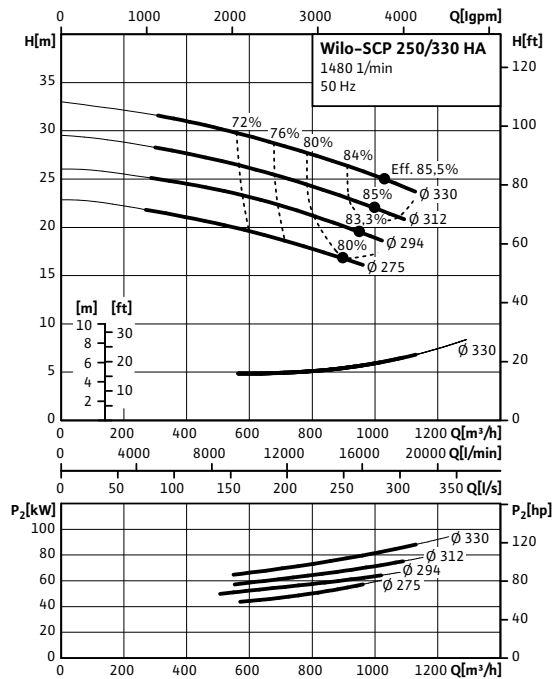

Pumps with axially split housing

Single pumps (heating, air-conditioning, cooling and industry)



Pump curves Wilo-SCP

Wilo-SCP 250/360 HA

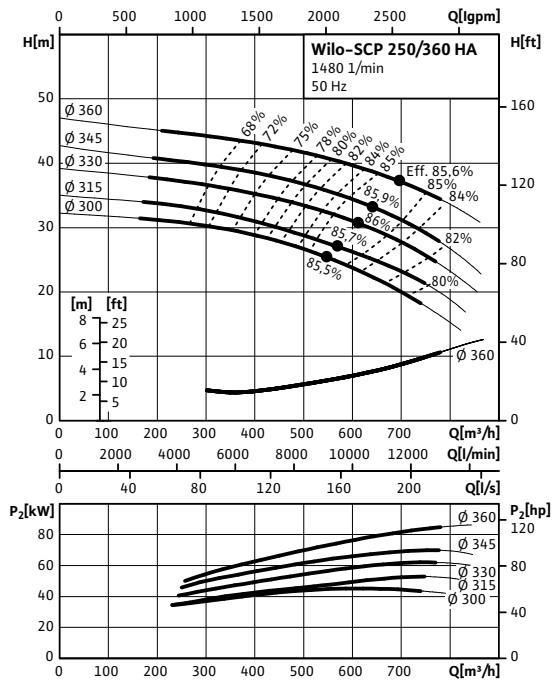

Wilo-SCP 250/390 HA

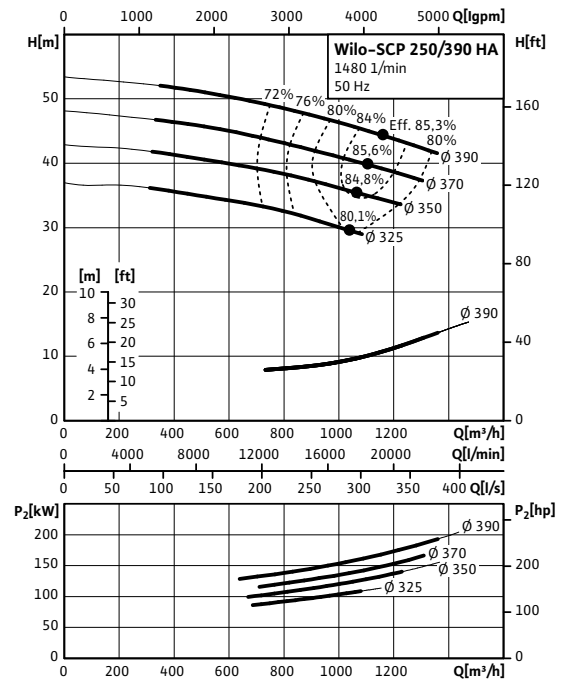

Wilo-SCP 250/450 HA

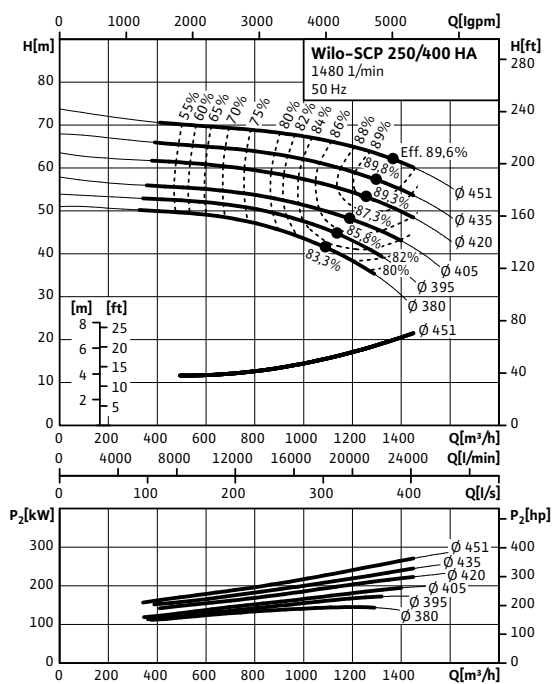

Wilo-SCP 250/570 HA

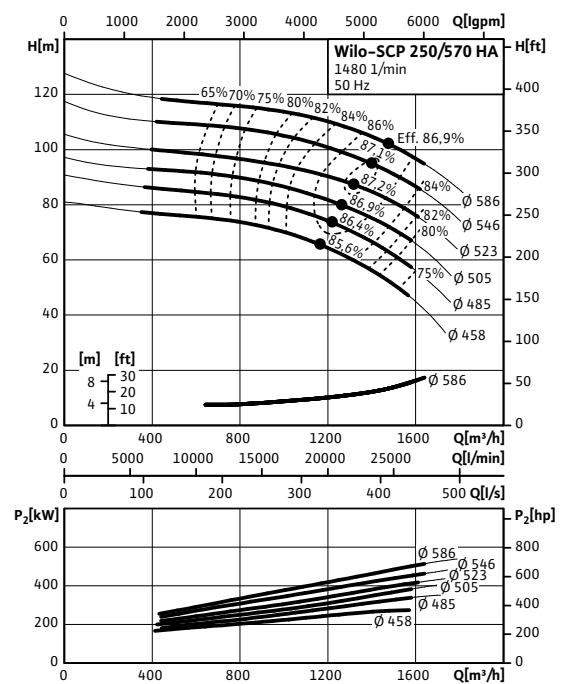

Pumps with axially split housing

Pumps with axially split housing

Single pumps (heating, air-conditioning, cooling and industry)

Pump curves Wilo-SCP

Wilo-SCP 250/700 DV

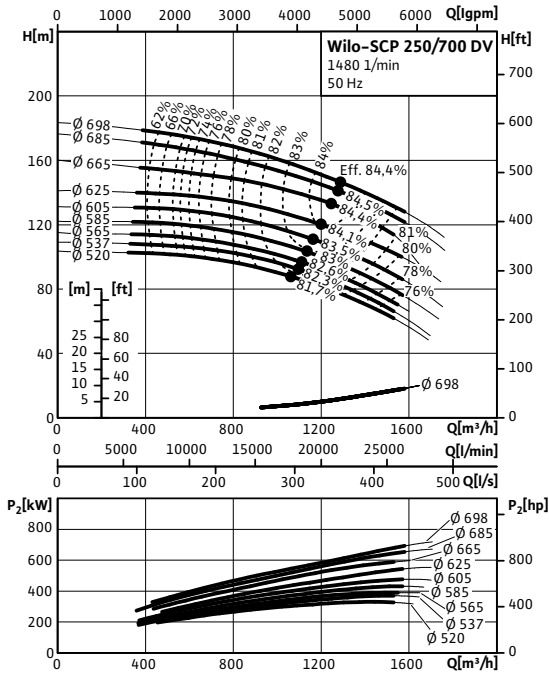

Wilo-SCP 250/740 DV

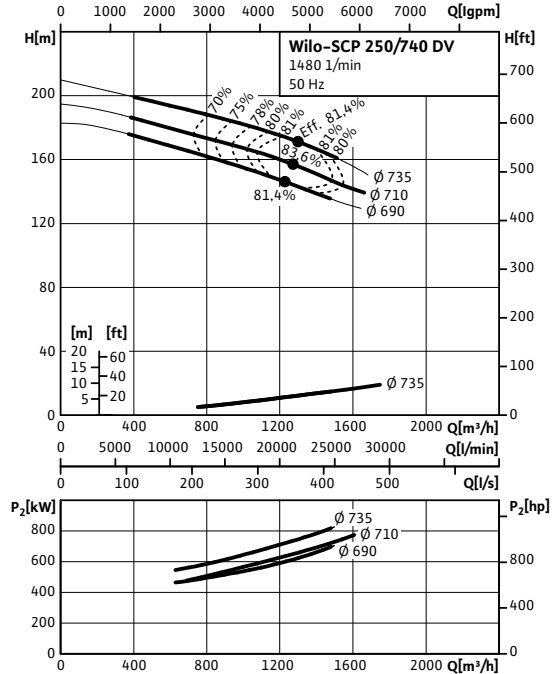

Wilo-SCP 300/330 HA

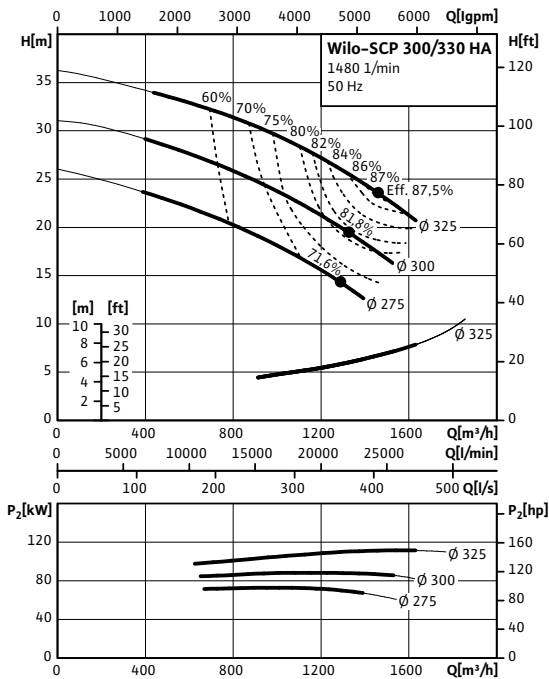

Wilo-SCP 300/330 HB

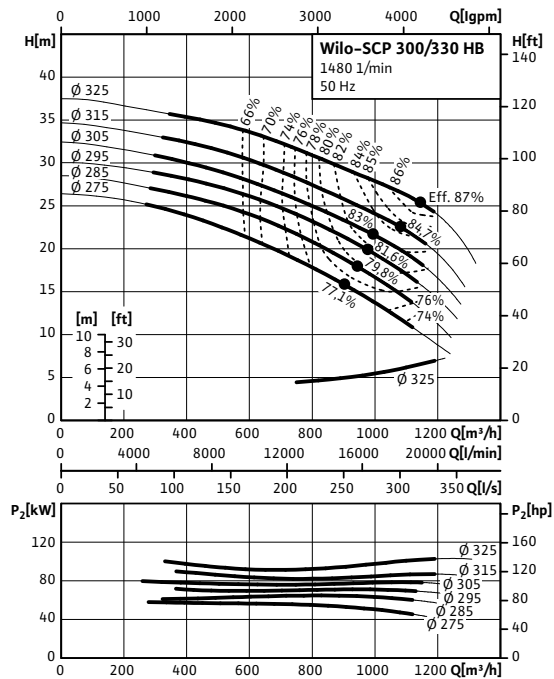

Pumps with axially split housing

Single pumps (heating, air-conditioning, cooling and industry)



Pump curves Wilo-SCP

Wilo-SCP 300/380 HA

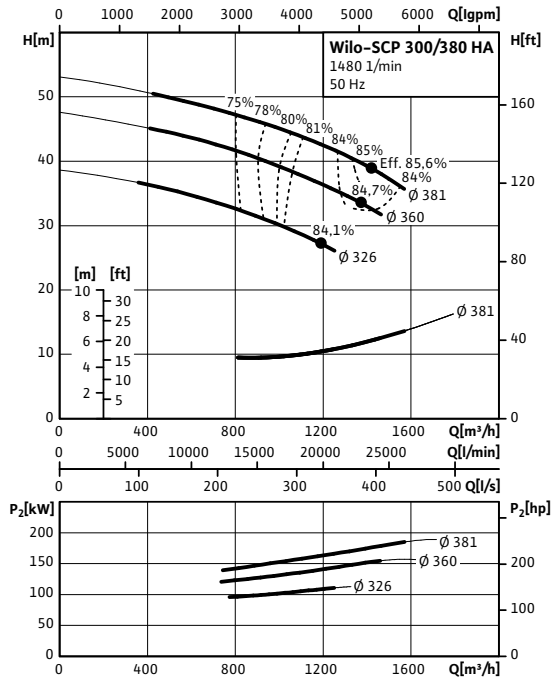

Wilo-SCP 300/400 HA

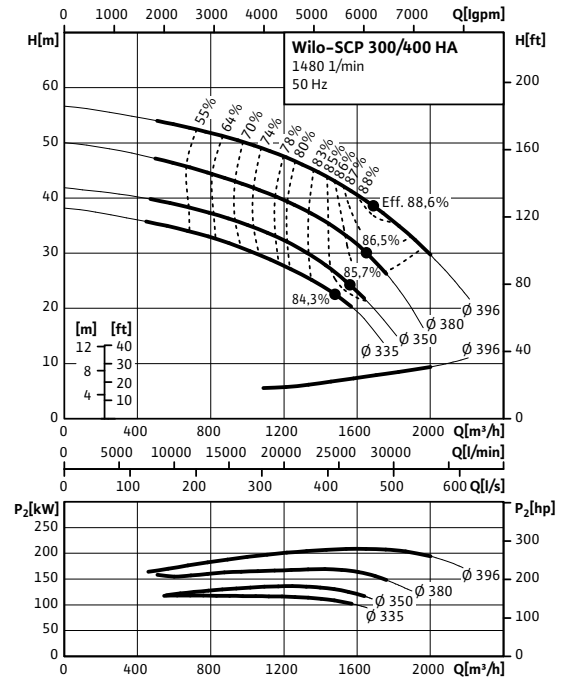

Wilo-SCP 300/490 HA

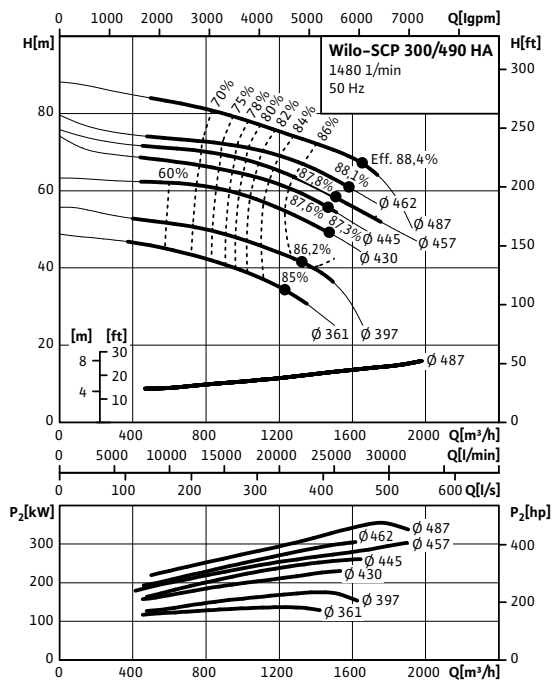

Wilo-SCP 300/570 HA

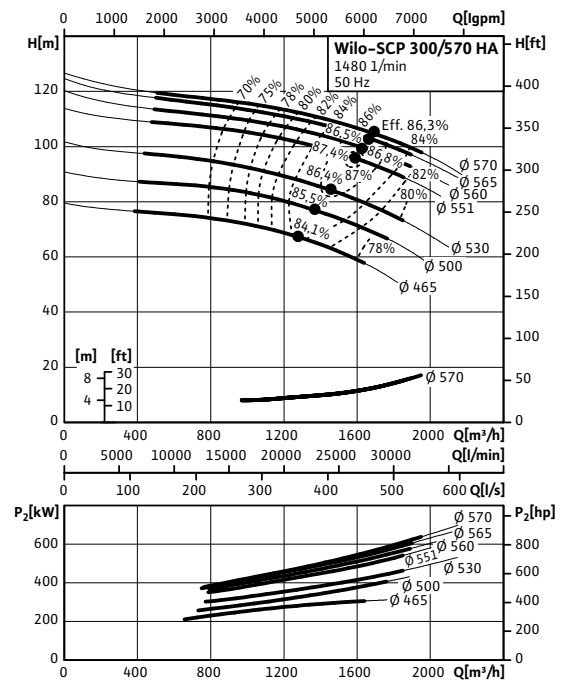

Pumps with axially split housing

Pumps with axially split housing

Single pumps (heating, air-conditioning, cooling and industry)

Pump curves Wilo-SCP

Wilo-SCP 300/590 HA

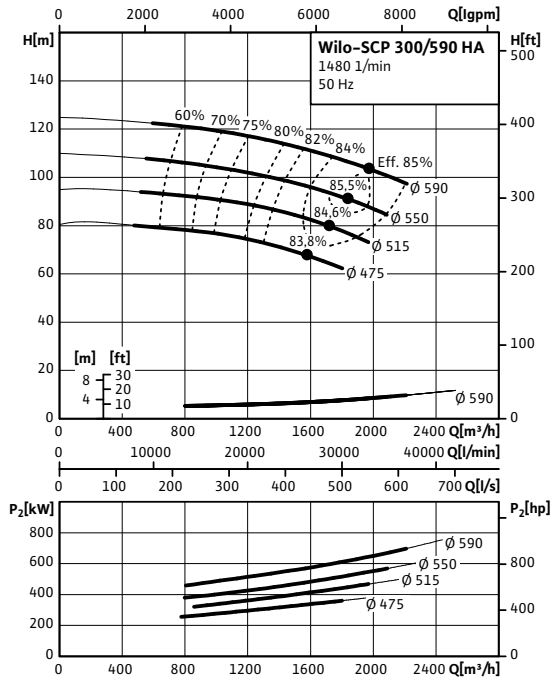

Wilo-SCP 300/660 DV

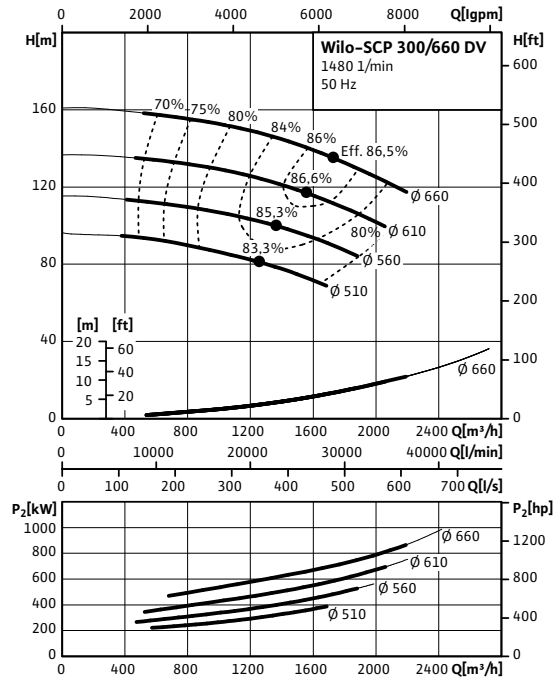

Wilo-SCP 350/470 HA

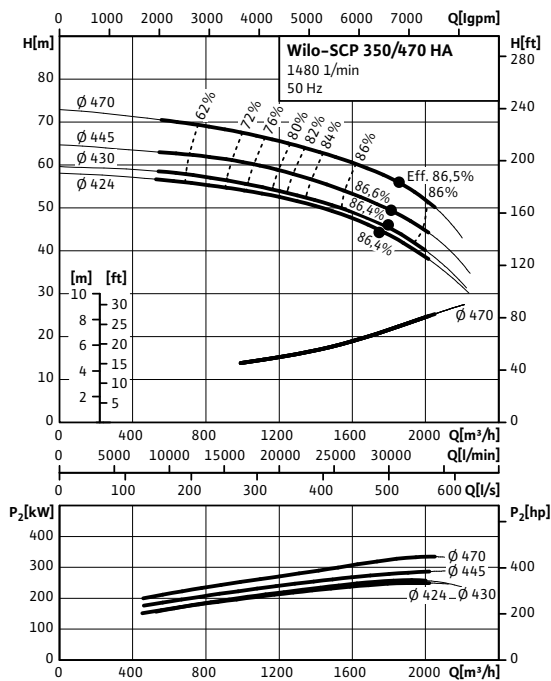

Wilo-SCP 350/500 HA

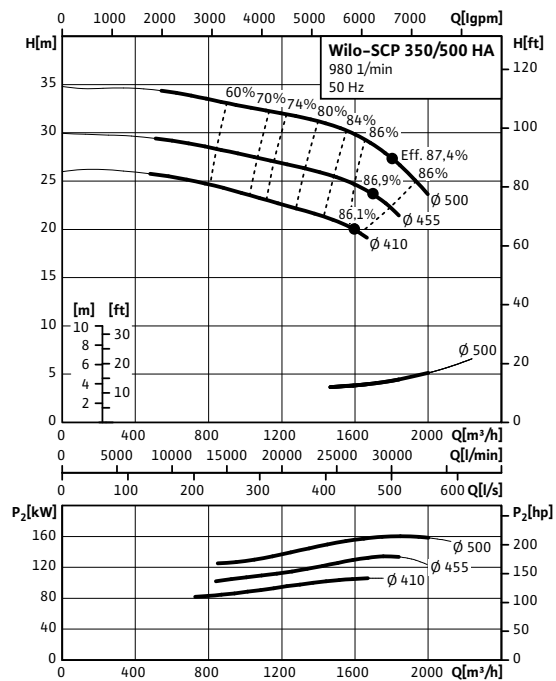

Pumps with axially split housing

Single pumps (heating, air-conditioning, cooling and industry)



Pump curves Wilo-SCP

Wilo-SCP 350/640 HA

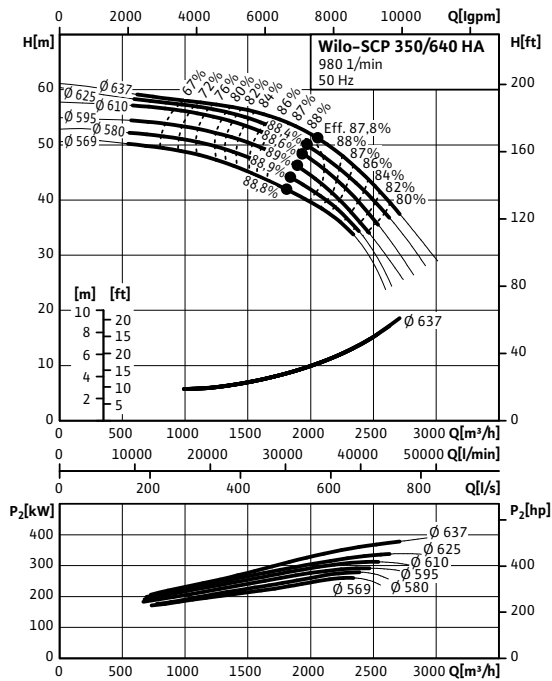

Wilo-SCP 400/480 HA

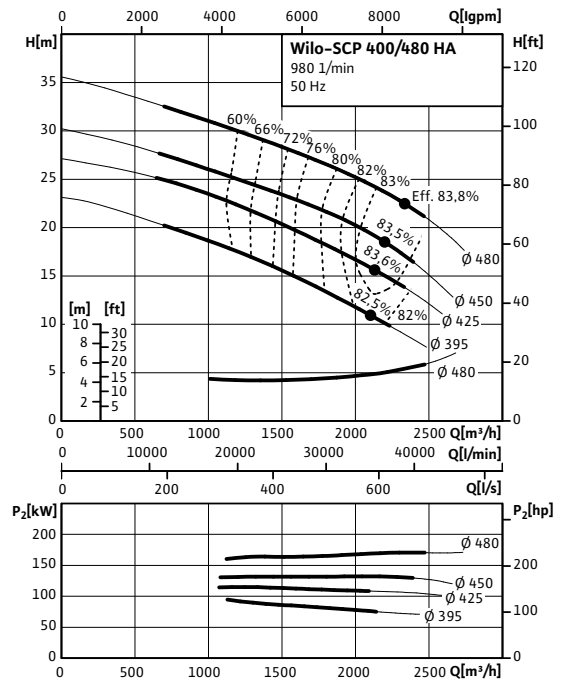

Wilo-SCP 400/540 HA

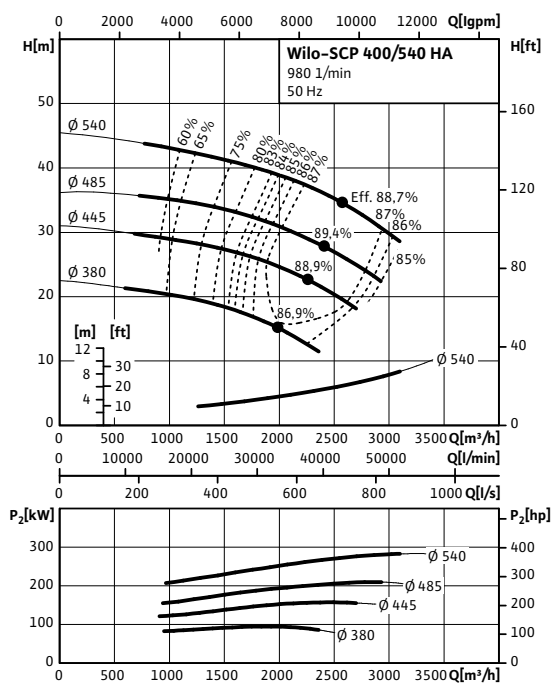

Wilo-SCP 400/550 HA

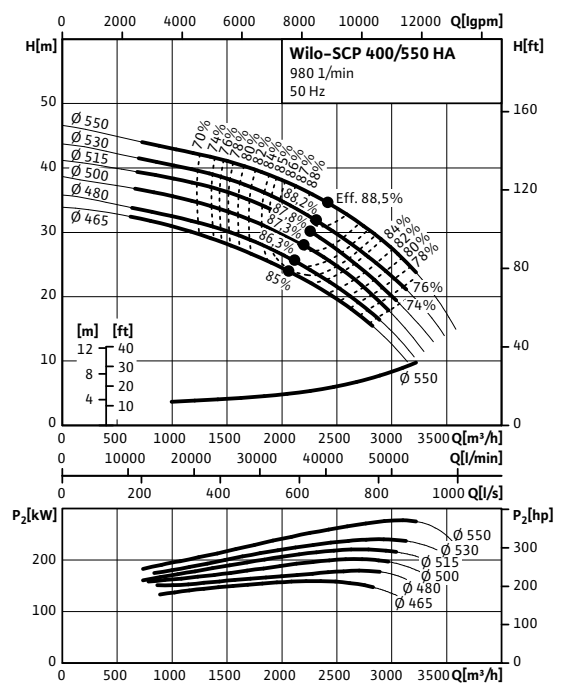

Pumps with axially split housing

Pumps with axially split housing

Single pumps (heating, air-conditioning, cooling and industry)

Pump curves Wilo-SCP

Wilo-SCP 400/660 DV

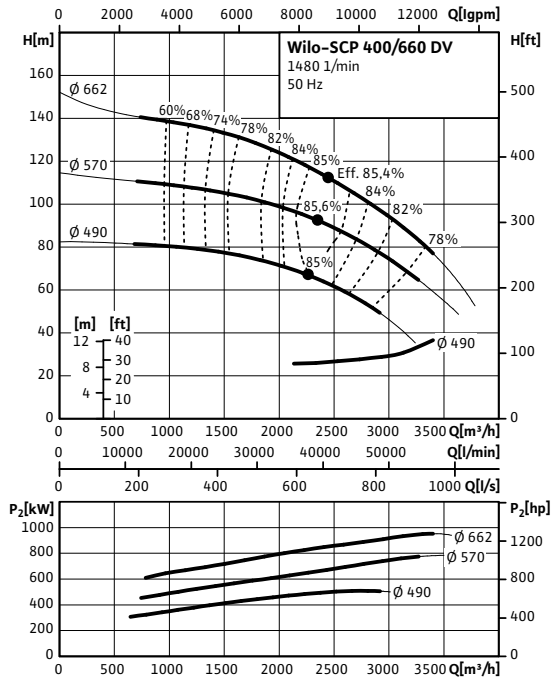

Wilo-SCP 400/690 HA

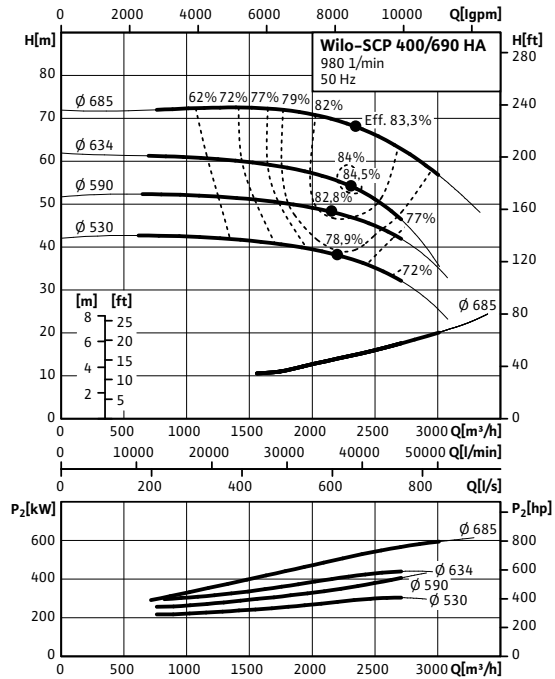

Wilo-SCP 400/710 HA

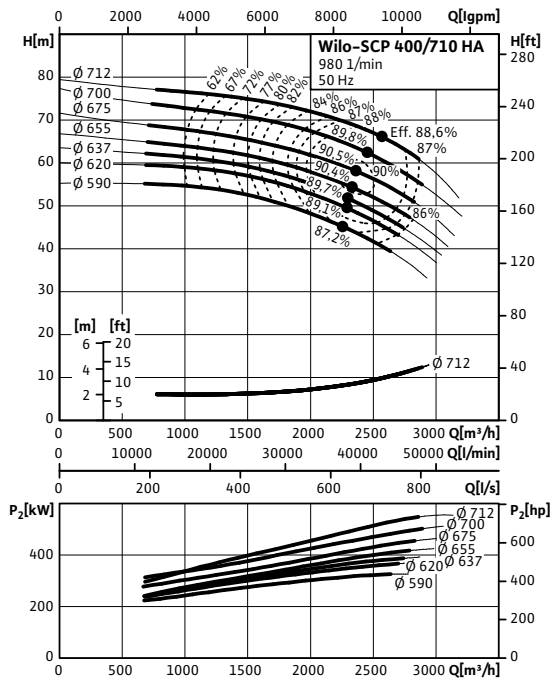

Pumps with axially split housing

Single pumps (heating, air-conditioning, cooling and industry)



Terminal diagram, motor data Wilo-SCP

Motor data						
Wilo-SCP ...	Number of poles	Nominal speed	Voltage/frequency	Nominal current (approx.)	Motor housing	Sound pressure level
	–	n	U	I _N 3~400 V		–
	–	[rpm]	–	[A]	[–]	[dBA]
11 kW	2	2900	3~400 V/50 Hz	19.6	160M	71
15 kW	2	2910	3~400 V/50 Hz	26.5	160M	71
18.5 kW	2	2920	3~400 V/50 Hz	32.2	160L	71
22 kW	2	2940	3~400 V/50 Hz	38.1	180M	77

Motor data						
Wilo-SCP ...	Number of poles	Nominal speed	Voltage/frequency	Nominal current (approx.)	Motor housing	Sound pressure level
	–	n	U	I _N 3~400 V		–
	–	[rpm]	–	[A]	[–]	[dBA]
1.1 kW	4	1410	1~230 V/50 Hz 3~400 V/50 Hz	2.7	90S	54
1.5 kW	4	1420	1~230 V/50 Hz 3~400 V/50 Hz	3.5	90L	54
2.2 kW	4	1430	1~230 V/50 Hz 3~400 V/50 Hz	4.8	100L	56
3 kW	4	1425	1~230 V/50 Hz 3~400 V/50 Hz	6.5	100L	56
4 kW	4	1445	1~230 V/50 Hz 3~400 V/50 Hz	8.6	112M	58
5.5 kW	4	1450	3~400 V/50 Hz	11.1	132S	61
7.5 kW	4	1450	3~400 V/50 Hz	15.5	132M	61
11 kW	4	1450	3~400 V/50 Hz	21.5	160M	63
15 kW	4	1455	3~400 V/50 Hz	29	160L	63
18.5 kW	4	1455	3~400 V/50 Hz	34.9	180M	69
22 kW	4	1455	3~400 V/50 Hz	40.8	180L	69
30 kW	4	1460	3~400 V/50 Hz	54.6	200L	70
37 kW	4	1470	3~400 V/50 Hz	67.1	225S	71
45 kW	4	1470	3~400 V/50 Hz	82	225M	71
55 kW	4	1470	3~400 V/50 Hz	100	250M	71
75 kW	4	1485	3~400 V/50 Hz	131	280S	74
90 kW	4	1485	3~400 V/50 Hz	157	280M	74
110 kW	4	1485	3~400 V/50 Hz	191	315S	80
132 kW	4	1485	3~400 V/50 Hz	228	315M	80
160 kW	4	1485	3~400 V/50 Hz	278	315S-M	77
200 kW	4	1480	3~400 V/50 Hz	370	315B	78
250 kW	4	1475	3~400 V/50 Hz	428	355M-L	79
315 kW	4	1485	3~400 V/50 Hz	531	355M-L	79
355 kW	4	1482	3~400 V/50 Hz	603	315D	87
400 kW	4	1484	3~400 V/50 Hz	679	315E	87
450 kW	4	1484	3~400 V/50 Hz	762	355C	87
500 kW	4	1485	3~400 V/50 Hz	845	355C	87
560 kW	4	1485	3~400 V/50 Hz	946	355D	87

Pumps with axially split housing

Pumps with axially split housing

Single pumps (heating, air-conditioning, cooling and industry)

Terminal diagram, motor data Wilo-SCP

Motor data						
Wilo-SCP ...	Number of poles	Nominal speed	Voltage/frequency	Nominal current (approx.)	Motor housing	Sound pressure level
	–	n	U	I_N 3~400 V		–
	–	[rpm]	–	[A]	[–]	[dBA]
630 kW	4	1485	3~400 V/50 Hz	1062	400L	90

Motor data						
Wilo-SCP ...	Number of poles	Nominal speed	Voltage/frequency	Nominal current (approx.)	Motor housing	Sound pressure level
	–	n	U	I_N 3~400 V		–
	–	[rpm]	–	[A]	[–]	[dBA]
90 kW	6	985	3~400 V/50 Hz	163	315S-M	69
110 kW	6	985	3~400 V/50 Hz	200	315S-M	69
132 kW	6	980	3~400 V/50 Hz	236	315S-M	69
160 kW	6	985	3~400 V/50 Hz	295	355M-L	73
200 kW	6	990	3~400 V/50 Hz	376	355M-L	73
250 kW	6	995	3~400 V/50 Hz	466	355M-L	73
315 kW	6	990	3~400 V/50 Hz	585	355M-L	73
355 kW	6	986	3~400 V/50 Hz	623	355C	83
400 kW	6	987	3~400 V/50 Hz	701	355D	83
450 kW	6	987	3~400 V/50 Hz	788	400L	85
500 kW	6	987	3~400 V/50 Hz	866	450L	85
560 kW	6	987	3~400 V/50 Hz	969	450A	85
630 kW	6	987	3~400 V/50 Hz	1089	450B	85

Pumps with axially split housing

Single pumps (heating, air-conditioning, cooling and industry)



Dimensions, weights Wilo-SCP

Dimension drawing: Pump with bare shaft end, single-stage version

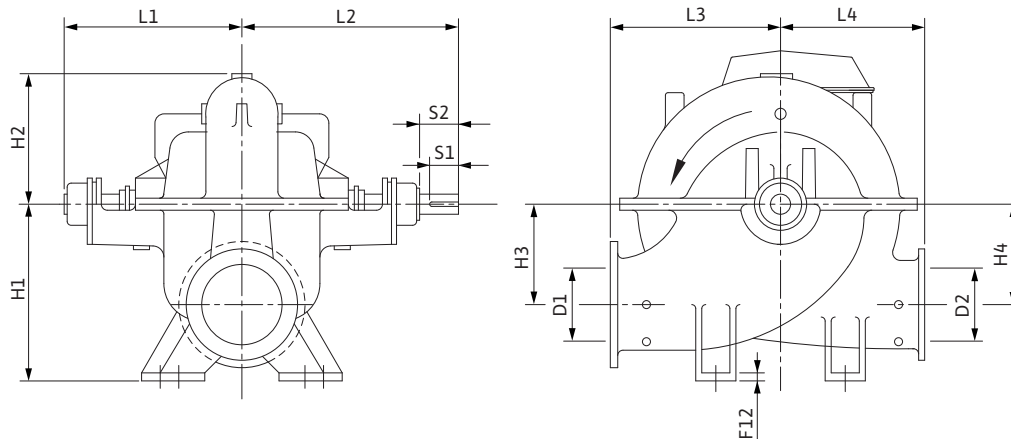

Dimension drawing: Pump base, single-stage version

Dimension drawing

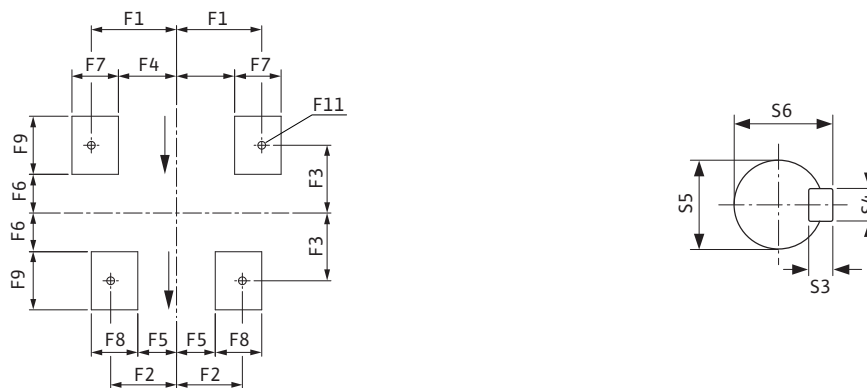

Pumps with axially split housing

Single pumps (heating, air-conditioning, cooling and industry)

Dimensions, weights Wilo-SCP

Dimension drawing: Pump with bare shaft end, two-stage version

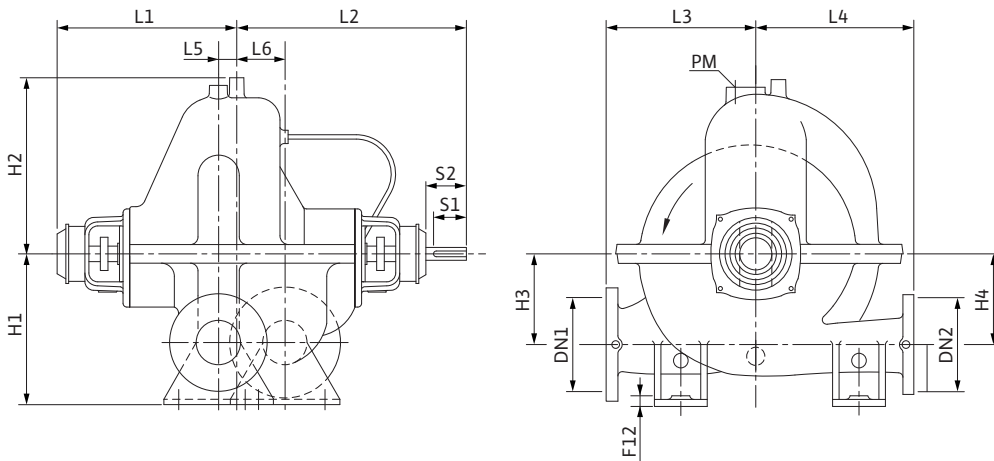

Dimension drawing: Pump base, two-stage version

Dimension drawing

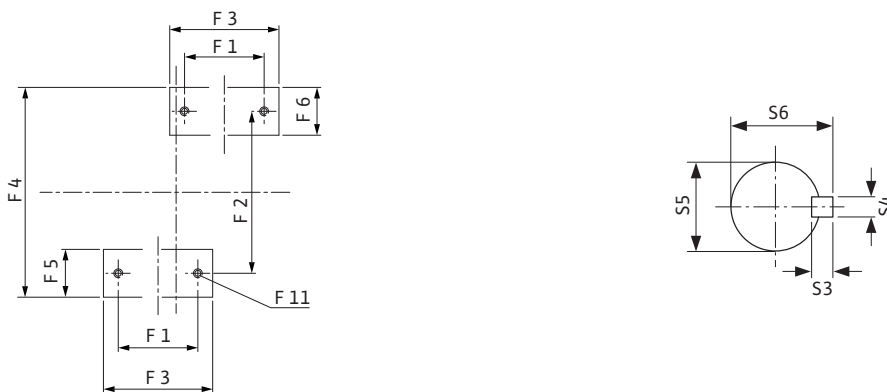

Pumps with axially split housing

Single pumps (heating, air-conditioning, cooling and industry)



Dimensions, weights Wilo-SCP

Dimensions, weights																													
Wilo-SCP ...	Nominal diameter		Flanges		Dimensions																						Weight approx.		
	DN ₂	DN ₁	PN ₁	PN ₂	H ₁	H ₂	H ₃	H ₄	L ₁	L ₂	L ₃	L ₄	F ₁	F ₂	F ₃	F ₄	F ₅	F ₆	F ₇	F ₈	F ₉	F ₁₁	S ₁	S ₂	S ₃	S ₄	S ₅	S ₆	M
	[mm]		-		[mm]																						[kg]		
50/80	50	80	16	16	200	135	117	117	294	369	200	170	70	60	100	100	-	-	-	-	18	45	75	6	6	19.5	22	92	
50/220	50	65	16	16	200	143	124	124	250	300	190	150	70	50	100	100	-	-	-	-	14	45	50	6	6	19.5	22	65	
50/340A	50	80	16	16	250	213.5	178	192	310	385	261	218	150	170	220	240	82	82	-	-	18	45	75	6	6	19.5	22	130	
65/390	65	80	16	16	280	230	190	215	290	389	300	250	180	160	240	240	90	90	-	-	18	46	76	7	8	24	27	150	
80/200	80	100	16	16	250	155	135	135	323	399	225	190	150	170	220	240	82	82	-	-	18	45	76	7	8	24	27	149	
80/230	80	100	16	16	250	165	146	146	338	399	225	190	150	170	220	240	82	82	-	-	18	45	76	7	8	24	27	135	
80/340	80	100	16	16	300	225	200	200	338	399	275	230	150	170	220	240	82	82	-	-	18	45	76	7	8	24	27	135	
100/270	100	125	16	16	270	198	165	165	338	399	285	230	150	95	100	85	30	50	100	100	18	45	76	7	8	24	27	160	
100/280	100	125	16	16	270	190	175	175	338	399	300	250	150	95	100	85	30	50	100	100	18	45	76	7	8	24	27	130	
100/360	100	125	16	16	320	245	225	225	338	399	350	275	150	95	110	85	30	60	100	100	18	45	76	7	8	24	27	147	
100/400	100	125	16	16	320	245	225	225	338	399	350	275	150	95	110	85	30	60	100	100	18	45	76	7	8	24	27	147	
125/290	125	150	16	16	320	240	213	213	385	458	350	275	150	95	110	85	30	60	100	100	18	82	88	7	8	29	32	160	
125/330	125	150	16	16	320	240	213	213	385	458	350	286	150	95	110	85	30	60	100	100	18	82	88	7	8	29	32	190	
125/440	125	150	16	16	400	284	274	274	385	458	400	350	145	115	160	80	50	100	100	120	22	82	88	7	8	29	32	220	
125/470	125	150	16	16	415	320	295	295	471	560	420	400	180	180	180	115	115	120	100	120	22	95	104	8	12	39	42	500	
150/290	150	200	16	16	380	255	220	220	385	458	350	265	140	140	142.5	75	75	92.5	-	100	18	82	88	7	8	29	32	350	
150/350	150	200	16	16	425	275	252	252	471	560	400	350	200	152	180	135	87	120	100	120	24	95	104	8	12	39	42	360	
150/390	150	200	16	16	343	280	229	229	411	474	406	330	200	130	160	135	65	100	100	120	22	88	104	8	12	39	42	305	
150/440	150	200	16	16	426	305	274	274	411	474	432	381	200	130	160	135	65	100	100	120	22	88	104	8	12	39	42	360	
150/450	150	200	16	16	426	305	274	274	411	474	432	381	200	130	160	135	65	100	100	120	22	88	104	8	12	39	42	360	
150/530	150	200	16	16	465	370	320	320	485	622.5	450	440	250	150	208	165	75	140	115	135	28	109	138	10	16	54	58	567	
150/580	150	200	16	16	455	365	328	328	511	605	570	520	200	152	260	115	73	192.5	114	135	25	109	138	10	16	54	58.5	580	
200/310	200	200	16	16	343	270	227	227	411	474	406.5	317.5	200	152	160	135	87	100	100	120	22	88	104	8	12	39	42	343	
200/320	200	250	16	16	426	290	248	248	411	474	432	318	200	152	160	135	87	100	100	120	24	88	104	8	12	39	42	385	
200/360A	200	250	16	16	465	330	285	285	471	560	440	350	220	220	180	155	155	120	100	120	22	95	104	8	12	39	42	520	
200/360B	200	300	16	16	450	320	276	276	471	560	470	350	200	152	170	135	87	120	100	120	24	95	104	8	12	39	42	460	
200/370	200	200	16	16	430	310	270	270	470	560	420	350	180	180	180	115	115	120	100	120	22	95	104	8	12	39	42	520	
200/390	200	250	16	16	464	315	292	292	525	612	483	381	200	152	160	115	73	93	114	135	25	109	137	10	16	54	59	579	
200/400	200	250	16	16	464	350	299	299	525	612	483	458	200	152	160	115	73	93	114	135	25	109	137	10	16	54	59	750	
200/440	200	250	16	16	465	330	300	300	485	622.5	440	400	200	150	208	120	75	140	115	135	28	109	138	10	16	54	58	460	
200/460	200	250	16	16	464	350	299	299	525	612	483	458	200	152	160	115	73	93	114	135	25	109	137	10	16	54	59	750	
200/480A	200	200	16	16	464	370	343	343	525	612	470	457	200	152	160	115	73	93	114	135	25	109	137	10	16	54	59	699	
200/560	200	250	16	16	546	395	356	356	594	693	521	458	275	200	230	175	100	155	150	150	28	132	181	12	20	69	74	770	
200/550	200	200	16	16	464	370	343	343	525	612	470	457	200	152	160	115	73	93	114	135	25	109	137	10	16	54	59	699	
200/660	200	250	16	16	640	460	440	440	565	693	600	500	260	170	278	160	100	190	120	175	30	130	141	12	20	69	62	1100	
250/250	250	250	16	16	410	265	222	222	385	473	370	260	200	152	120	135	87	70	100	100	18	82	88	7	8	29	32	270	
250/330	250	300	16	16	464	330	273	273	525	612	508	337	250	152	160	165	73	93	114	135	25	109	138	10	16	54	59	786	
250/360	250	300	16	16	540	340	320	320	485	623	517	380	250	175	160	165	90	93	120	135	24	109	138	10	16	54	58	540	
250/390	250	300	16	16	540	340	320	320	485	623	517	380	250	175	160	165	90	93	120	135	24	109	138	10	16	54	59	540	
250/450	250	300	16	16	546	380	343	343	594	693	534	457	275	200	230	175	100	155	150	150	29	132	156	12	20	69	74	906	
250/570	250	300	16	16	546	415	356	356	594	693	584	492	275	200	230	175	100	155	150	150	28	132	156	12	20	69	74	975	
250/700	250	300	16	25	622	476	407	407	704	825	635	559	270	170	270	200	100	180	120	180	28	146	168	14	22	79	86	1480	
250/740	250	300	16	16	622	476	407	407	704	825	635	559	270	170	270	200	100	180	120	180	28	146	168	14	22	79	86	1480	
300/330A	300	350	16	16	546	390	318	318	525	612	565	390	260	152	160	165	73	93	114	135	25	109	137	10	16	54	59	800	
300/330B	300	350	16	16	540	320	310	310	485	623	550	390	250	175	160	165	90	93	120	135	28	109	138	10	16	54	58	603	
300/380	300	350	16	16	546	375	318	318	525	612	559	391	260	152	160	165	73	93	114	135	25	109	138	10	16	54	58.5	1016	
300/400	300	400	16	16	610	390	350	350	536	668	550	350	260	200	175	160	100	100	150	150	28	109	138	10	16	54	58	880	
300/490	300	350	16	16	591	405	343	343	594	693	585	483	300	250	230	200	150	155	150	150	28	132	156	12	20	69	74	1110	
300/570	300	350	16	16	591	440	378	378	594	693	629	534	300	250	230	200	150	155	150	150	28	132	156	12	20	69	74	1255	
300/590	300	350	16	16	700	466	470	470	707	919	750	650	325	325	300	225	225	200	150	200	30	197	216	14	25	94	99	2000	
300/660	300	350	16	25	725	465	444.5	444.5	650.5	830	660.5	610	200	200	310	100	100	210	150	200	28	146	178						

Pumps with axially split housing

Single pumps (heating, air-conditioning, cooling and industry)

Dimensions, weights Wilo-SCP

Dimensions, weights

Wilo-SCP ...	Nominal diameter		Flanges		Dimensions																								Weight approx.
	DN ₂	DN ₁	PN ₁	PN ₂	H ₁	H ₂	H ₃	H ₄	L ₁	L ₂	L ₃	L ₄	F ₁	F ₂	F ₃	F ₄	F ₅	F ₆	F ₈	F ₉	F ₁₁	S ₁	S ₂	S ₃	S ₄	S ₅	S ₆	M	
	[mm]		-		[mm]																								[kg]
400/550	400	500	16	16	780	495	470	470	667	830	760	560	450	220	300	350	120	200	150	200	32	146	178	14	22	79	84	1453	
400/660	400	500	16	16	800	540	483	483	815	959	762	660	420	260	300	320	160	200	150	200	30	197	216	14	25	94	99	2700	
400/690	400	450	16	16	800	545	500	500	667	830	824	722	380	250	400	280	150	300	150	200	32	146	178	14	22	79	84	1561	
400/710	400	450	16	16	800	580	521	521	704	825	864	762	380	220	400	280	120	300	150	200	32	146	168	14	22	79	85.5	2515	

Details, plug connection

Wilo-SCP ...	CG	PG	PM	AC	CDS	CDD	CD	GD	Temp. sensor connection
	-								
	[inch]								
50/180HA	1/4	1/4	3/8	3/8	1/4	1/4	-	3/4	-
50/220HA	1/4	1/4	1/4	1/4	1/4	1/4	-	1	-
50/340HA	3/8	3/8	1/2	3/8	3/8	3/8	3/8	3/4	-
50/340DS	3/8	3/8	1/2	3/8	1/2	1/2	-	3/4	-
65/390HS	3/8	3/8	1/2	3/8	1/2	1/2	-	3/4	-
80/200HA	3/8	3/8	1/2	3/8	1/2	1/2	-	3/4	-
80/230HA	3/8	3/8	1/2	3/8	1/2	1/2	-	3/4	-
80/340HA	3/8	3/8	1/2	3/8	1/2	1/2	-	3/4	-
80/360DS	3/8	3/8	3/4	3/8	1/2	1/2	-	1/2	-
80/380DS	3/8	3/8	1/2	3/8	3/8	3/8	1/2	3/4	-
100/270HA	3/8	3/8	1/2	3/8	1/2	1/2	-	3/4	M8
100/280HA	3/8	3/8	1/2	3/8	1/2	1/2	-	3/4	M8
100/340DS	3/8	3/8	3/4	3/8	1/2	3/4	3/4	1/2	M8
100/360HA	3/8	3/8	1/2	3/8	1/2	1/2	-	3/4	M8
100/400HA	3/8	3/8	1/2	3/8	1/2	1/2	-	3/4	M8
100/410DS	3/8	3/8	3/4	3/8	1/2	1/2	-	3/4	M8
125/290HA	3/8	3/8	1/2	3/8	1/2	1/2	-	3/4	M8
125/330HA	3/8	3/8	1/2	3/8	1/2	1/2	-	3/4	M8
125/440HA	3/8	3/8	1/2	3/8	1/2	1/2	-	3/4	M8
125/460DS	3/8	3/8	3/4	3/8	1/2	1/2	1/2	3/4	M8
125/470HA	3/8	3/8	3/4	3/8	3/4	3/4	-	3/4	M8
150/290HA	3/8	3/8	1	3/8	1/2	1/2	-	3/4	M8
150/350HA	3/8	3/8	3/4	3/8	3/4	3/4	-	3/4	M8
150/390HA	3/8	3/8	1/2	3/8	3/4	3/4	-	3/4	M8
150/440HA	3/8	3/8	1/2	3/8	3/4	3/4	-	3/4	M8
150/450HA	3/8	3/8	1/2	3/8	3/4	3/4	-	3/4	M8
150/460DS	1/2	1/2	3/4	3/8	1/2	1/2	1/2	1/2	M8
150/530HA	3/8	3/8	1	3/8	3/4	3/4	-	3/4	M8
150/580HA	3/8	3/8	1	3/8	1/2	1/2	-	3/4	M8
200/310HA	3/8	3/8	1/2	3/8	3/4	3/4	-	3/4	M8
200/320HA	3/8	3/8	3/4	3/8	3/4	3/4	-	3/4	M8
200/360HA	3/8	3/8	3/4	3/8	3/4	3/4	-	3/4	M8
200/360HB	3/8	3/8	3/4	3/8	3/4	3/4	-	3/4	M8
200/370HA	3/8	3/8	3/4	3/8	3/4	3/4	-	3/4	M8

Pumps with axially split housing

Single pumps (heating, air-conditioning, cooling and industry)



Dimensions, weights Wilo-SCP

Details, plug connection

Wilo-SCP ...	CG	PG	PM	AC	CDS	CDD	CD	GD	Temp. sensor connection	
	-									
	[inch]									[mm]
200/390HA	3/8	3/8	1	3/8	3/4	3/4	-	3/4	M8	
200/400HA	3/8	3/8	1	3/8	3/4	3/4	-	3/4	M8	
200/440HA	3/8	3/8	1	3/8	3/4	3/4	-	3/4	M8	
200/460HA	3/8	3/8	1	3/8	3/4	3/4	-	3/4	M8	
200/480HA	3/8	3/8	1	3/8	1/2	1/2	-	3/4	M8	
200/550HA	3/8	3/8	1	3/8	1/2	1/2	-	3/4	M8	
200/560HA	3/8	3/8	1	3/8	1/2	1/2	-	3/4	M8	
200/660DV	3/8	3/8	1	3/8	1	1	-	1	M8	
250/250HA	3/8	3/8	1/2	3/8	1/2	1/2	-	3/4	M8	
250/330HA	3/8	3/8	1	3/8	1/2	1/2	-	3/4	M8	
250/360HA	3/8	3/8	1	3/8	3/4	3/4	-	3/4	M8	
250/390HA	3/8	3/8	1	3/8	3/4	3/4	-	3/4	M8	
250/450HA	3/8	3/8	1	3/8	1/2	1/2	-	1	M8	
250/570HA	3/8	3/8	1	3/8	1/2	1/2	-	1	M8	
250/700DV	3/8	3/8	1	3/8	1	1	-	1 1/4	M8	
250/740DV	3/8	3/8	1	3/8	1	1	-	1 1/4	M8	
300/330HA	3/8	3/8	1	3/8	1	1	-	3/4	M8	
300/330HB	3/8	3/8	1	3/8	3/4	3/4	-	3/4	M8	
300/380HA	3/8	3/8	1	3/8	1	1	-	3/4	M8	
300/400HA	3/8	3/8	1	3/8	3/4	3/4	-	3/4	M8	
300/490HA	3/8	3/8	1	3/8	1	1	-	1	M8	
300/570HA	3/8	3/8	1	3/8	1	1	-	1	M8	
300/590HA	3/8	3/8	1 1/2	3/8	1	1	-	1	M8	
300/660DV	3/8	3/8	1 1/2	3/8	1	1	-	1	M8	
350/470HA	3/8	3/8	1	3/8	1	1	-	1	M8	
350/500HA	3/8	3/8	1	3/8	1	1	-	1	M8	
350/640HA	3/8	3/8	1	3/8	1	1	-	1 1/4	M8	
400/480HA	3/8	3/8	1	3/8	1	1	-	1	M8	
400/540HA	3/8	3/8	1	3/8	1	1	-	1	M8	
400/550HA	3/8	3/8	1	3/8	1	1	-	1	M8	
400/660DV	1/2	1/2	1	3/8	1	1	-	1	M8	
400/690HA	3/8	3/8	1 1/2	3/8	1	1	-	1	M8	
400/710HA	3/8	3/8	1	3/8	1	1	-	1 1/4	M8	

Pumps with axially split housing

Pumps with axially split housing

Single pumps (heating, air-conditioning, cooling and industry)

Dimensions, weights Wilo-SCP

Dimension drawing: Complete installation on baseplate with motor, single-stage version

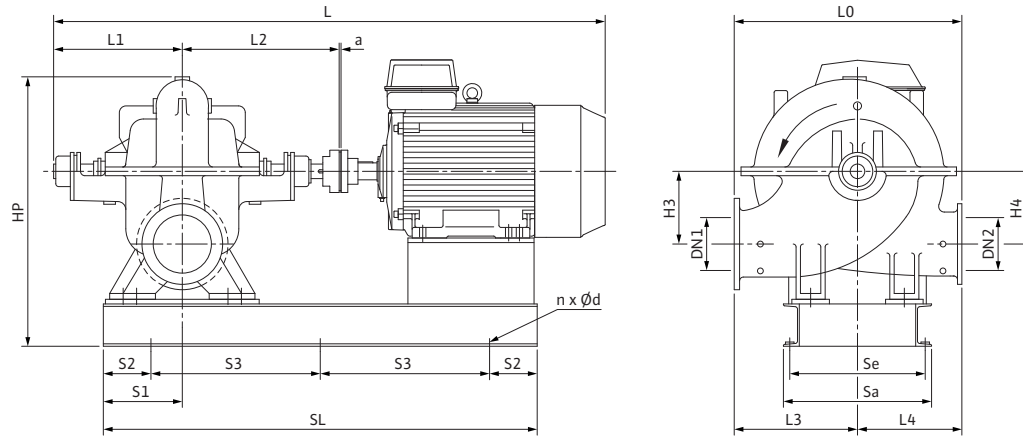

Dimension drawing: Complete installation on baseplate with motor, two-stage version

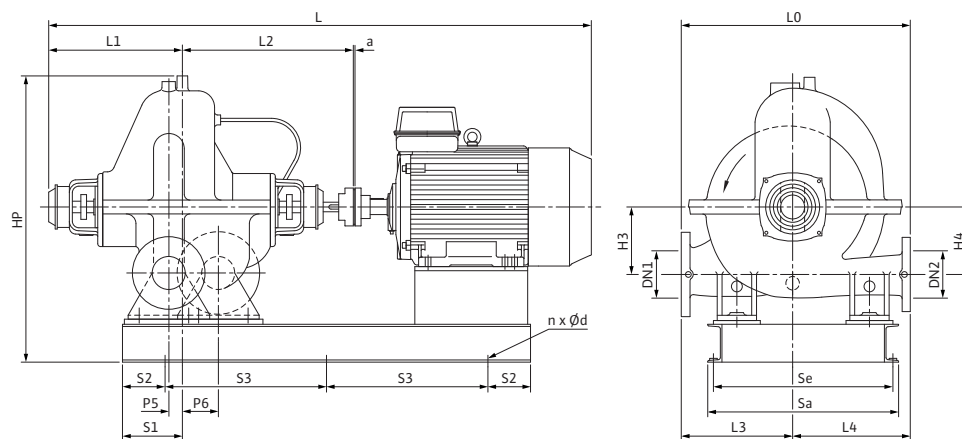

Dimensions, weights

Wilo-SCP ...	Nominal motor power	Number of poles	Overall length	Dimensions														Pump flange dimensions		
				P ₂	–	l ₀	H ₃	H ₄	HP	L	L ₁	L ₂	L ₃	L ₄	S ₁	S ₂	S ₃		Sa	Se
	[kW]	–		[mm]														[pcs. x mm]		
50/180HA	1.1	4	370	117	117	418	986	294	369	200	170	130	145	–	360	320	830	–	–	4x19
50/180HA	1.5	4	370	117	117	418	986	294	369	200	170	130	145	–	360	320	830	–	–	4x19
50/220HA	1.1	4	340	124	124	426	873	250	300	190	150	130	145	–	360	320	830	–	–	4x19
50/220HA	1.5	4	340	124	124	426	873	250	300	190	150	130	145	–	360	320	830	–	–	4x19
50/220HA	2.2	4	340	124	124	426	908	250	300	190	150	130	145	–	360	320	830	–	–	4x19
50/340HA	3	4	479	178	192	547	1053	310	385	261	218	150	165	–	390	350	930	–	–	4x19
50/340HA	4	4	479	178	192	547	1097	310	385	261	218	150	165	–	390	350	930	–	–	4x19
50/340HA	5.5	4	479	178	192	547	1177	310	385	261	218	150	165	–	390	350	930	–	–	4x19
50/340HA	7.5	4	479	178	192	567	1177	310	385	261	218	150	185	–	450	400	1030	–	–	4x24

Pumps with axially split housing

Single pumps (heating, air-conditioning, cooling and industry)



Dimensions, weights Wilo-SCP

Dimensions, weights

Wilo-SCP ...	Nominal motor power	Number of poles	Overall length	Dimensions																Pump flange dimensions
	P ₂			–	l ₀	H ₃	H ₄	HP	L	L ₁	L ₂	L ₃	L ₄	S ₁	S ₂	S ₃	Sa	Se	SL	P ₅
	[kW]	–	[mm]																[pcs. x mm]	
50/340HA	11	4	479	178	192	567	1287	310	385	261	218	150	205	–	490	440	1150	–	–	4x24
50/340DS	5.5	4	515	168	185	618	1240	341	417	300	215	200	185	–	450	400	1030	43	118	4x24
50/340DS	7.5	4	515	168	185	618	1240	341	417	300	215	200	205	–	490	440	1150	43	118	4x24
50/340DS	11	4	515	168	185	618	1350	341	417	300	215	200	205	–	490	440	1150	43	118	4x24
50/340DS	15	4	515	168	185	618	1350	341	417	300	215	200	225	–	540	490	1290	43	118	4x24
50/340DS	18.5	4	515	168	185	618	1393	341	417	300	215	200	225	–	540	490	1290	43	118	4x24
50/340DS	22	4	515	168	185	618	1393	341	417	300	215	200	225	–	540	490	1290	43	118	4x24
50/340DS	30	4	515	168	185	618	1429	341	417	300	215	200	225	–	540	490	1290	43	118	4x24
65/390HS	5.5	4	550	190	215	613	1161	290	389	300	250	150	185	–	450	400	1030	–	–	4x24
65/390HS	7.5	4	550	190	215	613	1161	290	389	300	250	150	185	–	450	400	1030	–	–	4x24
65/390HS	11	4	550	190	215	613	1271	290	389	300	250	150	205	–	490	440	1150	–	–	4x24
65/390HS	15	4	550	190	215	613	1271	290	389	300	250	150	205	–	490	440	1150	–	–	4x24
65/390HS	18.5	4	550	190	215	613	1314	290	389	300	250	150	205	–	490	440	1150	–	–	4x24
65/390HS	22	4	550	190	215	613	1314	290	389	300	250	150	205	–	490	440	1150	–	–	4x24
80/200HA	11	2	415	135	135	508	1314	323	399	225	190	150	205	–	490	440	1150	–	–	4x24
80/200HA	15	2	415	135	135	508	1314	323	399	225	190	150	205	–	490	440	1150	–	–	4x24
80/200HA	18.5	2	415	135	135	508	1314	323	399	225	190	150	205	–	490	440	1150	–	–	4x24
80/200HA	22	2	415	135	135	508	1357	323	399	225	190	150	205	–	490	440	1150	–	–	4x24
80/230HA	1.5	4	415	146	146	498	1060	338	399	225	190	150	165	–	390	350	930	–	–	4x19
80/230HA	2.2	4	415	146	146	498	1095	338	399	225	190	150	165	–	390	350	930	–	–	4x19
80/230HA	3	4	415	146	146	498	1095	338	399	225	190	150	165	–	390	350	930	–	–	4x19
80/230HA	4	4	415	146	146	498	1139	338	399	225	190	150	165	–	390	350	930	–	–	4x19
80/230HA	5.5	4	415	146	146	518	1219	338	399	225	190	150	185	–	450	400	1030	–	–	4x24
80/340HA	4	4	505	200	200	608	1139	338	399	275	230	150	165	–	390	350	930	–	–	4x19
80/340HA	5.5	4	505	200	200	628	1219	338	399	275	230	150	185	–	450	400	1030	–	–	4x24
80/340HA	7.5	4	505	200	200	628	1219	338	399	275	230	150	185	–	450	400	1030	–	–	4x24
80/340HA	11	4	505	200	200	628	1329	338	399	275	230	150	205	–	490	440	1150	–	–	4x24
80/340HA	15	4	505	200	200	628	1329	338	399	275	230	150	225	–	540	490	1290	–	–	4x24
80/340HA	18.5	4	505	200	200	628	1372	338	399	275	230	150	205	–	490	440	1150	–	–	4x24
80/360DS	15	4	545	192	192	733	1417	375	450	280	265	165	250	–	610	550	1440	35	85	4x29
80/360DS	18.5	4	545	192	192	733	1460	375	450	280	265	165	250	–	610	550	1440	35	85	4x29
80/360DS	22	4	545	192	192	733	1460	375	450	280	265	165	250	–	610	550	1440	35	85	4x29
80/360DS	30	4	545	192	192	733	1496	375	450	280	265	165	250	–	610	550	1440	35	85	4x29
80/360DS	37	4	545	192	192	733	1596	375	450	280	265	165	250	–	610	550	1440	35	85	4x29
80/360DS	45	4	545	192	192	733	1596	375	450	280	265	165	250	–	610	550	1440	35	85	4x29
80/380DS	7.5	4	577	192	208	693	1323	383	459	335	242	230	205	–	490	440	1150	52.5	139	4x24
80/380DS	11	4	577	192	208	693	1433	383	459	335	242	230	225	–	540	490	1290	52.5	139	4x24
80/380DS	15	4	577	192	208	693	1433	383	459	335	242	230	250	–	610	550	1440	52.5	139	4x29
80/380DS	18.5	4	577	192	208	693	1476	383	459	335	242	230	225	–	540	490	1290	52.5	139	4x24
80/380DS	22	4	577	192	208	693	1476	383	459	335	242	230	250	–	610	550	1440	52.5	139	4x29

Pumps with axially split housing

Pumps with axially split housing

Single pumps (heating, air-conditioning, cooling and industry)

Dimensions, weights Wilo-SCP

Dimensions, weights

Wilo-SCP ...	Nominal motor power	Number of poles	Overall length	Dimensions																Pump flange dimensions
	P ₂	–	l ₀	H ₃	H ₄	HP	L	L ₁	L ₂	L ₃	L ₄	S ₁	S ₂	S ₃	Sa	Se	SL	P ₅	P ₆	n x Ø d _L
	[kW]	–	[mm]																[pcs. x mm]	
80/380DS	30	4	577	192	208	693	1512	383	459	335	242	230	250	–	610	550	1440	52.5	139	4x29
80/380DS	37	4	577	192	208	693	1612	383	459	335	242	230	250	–	610	550	1440	52.5	139	4x29

Dimensions, weights

Wilo-SCP ...	Nominal motor power	Number of poles	Over-all length	Dimensions																Pump flange dimensions
	P ₂	–	l ₀	H ₃	H ₄	HP	L	L ₁	L ₂	L ₃	L ₄	S ₁	S ₂	S ₃	Sa	Se	SL	P ₅	P ₆	n x Ø d _L
	[kW]	–	[mm]																[pcs. x mm]	
100/270HA	4	4	515	165	165	571	1139	338	399	285	230	215	205	–	490	440	1150	–	–	4x24
100/270HA	5.5	4	515	165	165	571	1219	338	399	285	230	215	205	–	490	440	1150	–	–	4x24
100/270HA	7.5	4	515	165	165	571	1219	338	399	285	230	215	205	–	490	440	1150	–	–	4x24
100/270HA	11	4	515	165	165	571	1329	338	399	285	230	215	205	–	490	440	1150	–	–	4x24
100/280HA	4	4	550	175	175	563	1139	338	399	300	250	215	205	–	490	440	1150	–	–	4x24
100/280HA	5.5	4	550	175	175	563	1219	338	399	300	250	215	205	–	490	440	1150	–	–	4x24
100/280HA	7.5	4	550	175	175	563	1219	338	399	300	250	215	205	–	490	440	1150	–	–	4x24
100/280HA	11	4	550	175	175	563	1329	338	399	300	250	215	205	–	490	440	1150	–	–	4x24
100/280HA	15	4	550	175	175	563	1329	338	399	300	250	215	225	–	540	490	1290	–	–	4x24
100/280HA	18.5	4	550	175	175	563	1372	338	399	300	250	215	225	–	540	490	1290	–	–	4x24
100/340DS	18.5	4	630	200	200	823	1526	405	486	330	300	240	250	–	610	550	1440	32.5	75	4x29
100/340DS	22	4	630	200	200	823	1526	405	486	330	300	240	250	–	610	550	1440	32.5	75	4x29
100/340DS	30	4	630	200	200	823	1562	405	486	330	300	240	250	–	610	550	1440	32.5	75	4x29
100/340DS	37	4	630	200	200	823	1662	405	486	330	300	240	250	–	610	550	1440	32.5	75	4x29
100/340DS	45	4	630	200	200	823	1662	405	486	330	300	240	250	–	610	550	1440	32.5	75	4x29
100/340DS	55	4	630	200	200	843	1681	405	486	330	300	240	320	–	730	670	1840	32.5	75	4x29
100/360HA	5.5	4	625	225	225	668	1219	338	399	350	275	215	205	–	490	440	1150	–	–	4x24
100/360HA	7.5	4	625	225	225	668	1219	338	399	350	275	215	205	–	490	440	1150	–	–	4x24
100/360HA	11	4	625	225	225	668	1329	338	399	350	275	215	205	–	490	440	1150	–	–	4x24
100/360HA	15	4	625	225	225	668	1329	338	399	350	275	215	225	–	540	490	1290	–	–	4x24
100/360HA	18.5	4	625	225	225	668	1372	338	399	350	275	215	225	–	540	490	1290	–	–	4x24
100/360HA	22	4	625	225	225	668	1372	338	399	350	275	215	225	–	540	490	1290	–	–	4x24
100/360HA	30	4	625	225	225	668	1408	338	399	350	275	215	225	–	540	490	1290	–	–	4x24
100/400HA	15	4	625	225	225	668	1329	338	399	350	275	215	225	–	540	490	1290	–	–	4x24
100/400HA	18.5	4	625	225	225	668	1372	338	399	350	275	215	225	–	540	490	1290	–	–	4x24
100/400HA	22	4	625	225	225	668	1372	338	399	350	275	215	225	–	540	490	1290	–	–	4x24
100/400HA	30	4	625	225	225	668	1408	338	399	350	275	215	225	–	540	490	1290	–	–	4x24
100/400HA	37	4	625	225	225	668	1508	338	399	350	275	215	250	–	610	550	1440	–	–	4x29
100/400HA	45	4	625	225	225	668	1508	338	399	350	275	215	250	–	610	550	1440	–	–	4x29
100/400HA	55	4	625	225	225	688	1527	338	399	350	275	215	290	–	660	600	1640	–	–	4x29
100/410DS	22	4	620	220	220	818	1570	425	510	320	300	182	250	–	610	550	1440	39.5	102	4x29

Pumps with axially split housing

Single pumps (heating, air-conditioning, cooling and industry)



Dimensions, weights Wilo-SCP

Dimensions, weights

Wilo-SCP ...	Nominal motor power	Number of poles	Over-all length	Dimensions																Pump flange dimensions
				P ₂	–	l ₀	H ₃	H ₄	HP	L	L ₁	L ₂	L ₃	L ₄	S ₁	S ₂	S ₃	Sa	Se	
	[kW]	–	[mm]																[pcs. x mm]	
100/410DS	30	4	620	220	220	818	1606	425	510	320	300	182	250	–	610	550	1440	39.5	102	4x29
100/410DS	37	4	620	220	220	818	1706	425	510	320	300	182	250	–	610	550	1440	39.5	102	4x29
100/410DS	45	4	620	220	220	818	1706	425	510	320	300	182	250	–	610	550	1440	39.5	102	4x29
100/410DS	55	4	620	220	220	838	1725	425	510	320	300	182	320	–	730	670	1840	39.5	102	4x29
100/410DS	75	4	620	220	220	838	1901	425	510	320	300	182	320	–	730	670	1840	39.5	102	4x29
100/410DS	90	4	620	220	220	838	1901	425	510	320	300	182	320	–	730	670	1840	39.5	102	4x29
125/290HA	7.5	4	625	213	213	663	1325	385	458	350	275	215	205	–	490	440	1150	–	–	4x24
125/290HA	11	4	625	213	213	663	1435	385	458	350	275	215	225	–	540	490	1290	–	–	4x24
125/290HA	15	4	625	213	213	663	1435	385	458	350	275	215	225	–	540	490	1290	–	–	4x24
125/290HA	18.5	4	625	213	213	663	1478	385	458	350	275	215	225	–	540	490	1290	–	–	4x24
125/290HA	22	4	625	213	213	663	1478	385	458	350	275	215	225	–	540	490	1290	–	–	4x24
125/330HA	15	4	636	213	213	663	1435	385	458	350	286	215	225	–	540	490	1290	–	–	4x24
125/330HA	18.5	4	636	213	213	663	1478	385	458	350	286	215	225	–	540	490	1290	–	–	4x24
125/330HA	22	4	636	213	213	663	1478	385	458	350	286	215	225	–	540	490	1290	–	–	4x24
125/330HA	30	4	636	213	213	663	1514	385	458	350	286	215	250	–	610	550	1440	–	–	4x29
125/330HA	37	4	636	213	213	663	1614	385	458	350	286	215	250	–	610	550	1440	–	–	4x29
125/330HA	45	4	636	213	213	663	1614	385	458	350	286	215	250	–	610	550	1440	–	–	4x29
125/440HA	22	4	750	274	274	807	1478	385	458	400	350	210	290	–	660	600	1640	–	–	4x29
125/440HA	30	4	750	274	274	807	1514	385	458	400	350	210	290	–	660	600	1640	–	–	4x29
125/440HA	37	4	750	274	274	807	1614	385	458	400	350	210	290	–	660	600	1640	–	–	4x29
125/440HA	45	4	750	274	274	807	1614	385	458	400	350	210	290	–	660	600	1640	–	–	4x29
125/440HA	55	4	750	274	274	807	1633	385	458	400	350	210	320	–	730	670	1840	–	–	4x29
125/440HA	75	4	750	274	274	807	1809	385	458	400	350	210	320	–	730	670	1840	–	–	4x29
125/440HA	90	4	750	274	274	807	1809	385	458	400	350	210	320	–	730	670	1840	–	–	4x29
125/440HA	110	4	750	274	274	914	2059	385	458	400	350	210	250	–	670	610	1650	–	–	4x29
125/460DS	37	4	750	245	245	933	1831	480	580	400	350	205	320	–	730	670	1840	45	110	4x29
125/460DS	45	4	750	245	245	933	1831	480	580	400	350	205	320	–	730	670	1840	45	110	4x29
125/460DS	55	4	750	245	245	933	1850	480	580	400	350	205	320	–	730	670	1840	45	110	4x29
125/460DS	75	4	750	245	245	933	2026	480	580	400	350	205	320	–	730	670	1840	45	110	4x29
125/460DS	90	4	750	245	245	933	2026	480	580	400	350	205	320	–	730	670	1840	45	110	4x29
125/460DS	110	4	750	245	245	933	2276	480	580	400	350	205	320	–	730	670	1840	45	110	4x29
125/460DS	132	4	750	245	245	933	2386	480	580	400	350	205	320	–	730	670	1840	45	110	4x29
125/460DS	160	4	750	245	245	933	2222	480	580	400	350	205	320	–	730	670	1840	45	110	4x29
125/460DS	200	4	750	245	245	1040	2636	480	580	400	350	205	250	–	670	610	2000	45	110	4x29
125/470HA	37	4	820	295	295	858	1801	470	560	420	400	245	320	–	730	670	1840	–	–	4x29
125/470HA	45	4	820	295	295	858	1801	470	560	420	400	245	320	–	730	670	1840	–	–	4x29
125/470HA	55	4	820	295	295	858	1820	470	560	420	400	245	320	–	730	670	1840	–	–	4x29
125/470HA	75	4	820	295	295	858	1996	470	560	420	400	245	320	–	730	670	1840	–	–	4x29
125/470HA	90	4	820	295	295	858	1996	470	560	420	400	245	320	–	730	670	1840	–	–	4x29
125/470HA	110	4	820	295	295	858	2246	470	560	420	400	245	320	–	730	670	1840	–	–	4x29
125/470HA	132	4	820	295	295	858	2356	470	560	420	400	245	370	–	860	790	2140	–	–	4x29

Pumps with axially split housing

Pumps with axially split housing

Single pumps (heating, air-conditioning, cooling and industry)

Dimensions, weights Wilo-SCP

Dimensions, weights																				
Wilo-SCP ...	Nominal motor power	Number of poles	Over-all length	Dimensions																Pump flange dimensions
	P ₂	–	l ₀	H ₃	H ₄	HP	L	L ₁	L ₂	L ₃	L ₄	S ₁	S ₂	S ₃	Sa	Se	SL	P ₅	P ₆	n x Ø d _L
	[kW]	–	[mm]																[pcs. x mm]	
150/290HA	15	4	615	220	220	738	1435	385	458	350	265	205	250	–	610	550	1440	–	–	4x29
150/290HA	18.5	4	615	220	220	738	1478	385	458	350	265	205	250	–	610	550	1440	–	–	4x29
150/290HA	22	4	615	220	220	738	1478	385	458	350	265	205	250	–	610	550	1440	–	–	4x29
150/290HA	30	4	615	220	220	738	1514	385	458	350	265	205	250	–	610	550	1440	–	–	4x29
150/290HA	37	4	615	220	220	738	1614	385	458	350	265	205	250	–	610	550	1440	–	–	4x29
150/350HA	30	4	750	252	252	823	1702	471	560	400	350	265	320	–	730	670	1840	–	–	4x29
150/350HA	37	4	750	252	252	823	1802	471	560	400	350	265	320	–	730	670	1840	–	–	4x29
150/350HA	45	4	750	252	252	823	1802	471	560	400	350	265	320	–	730	670	1840	–	–	4x29
150/350HA	55	4	750	252	252	823	1821	471	560	400	350	265	320	–	730	670	1840	–	–	4x29
150/350HA	75	4	750	252	252	823	1997	471	560	400	350	265	320	–	730	670	1840	–	–	4x29
150/390HA	18.5	4	736	229	229	746	1520	411	474	406	330	265	290	–	660	600	1640	–	–	4x29
150/390HA	22	4	736	229	229	746	1520	411	474	406	330	265	290	–	660	600	1640	–	–	4x29
150/390HA	30	4	736	229	229	746	1556	411	474	406	330	265	290	–	660	600	1640	–	–	4x29
150/390HA	37	4	736	229	229	746	1656	411	474	406	330	265	290	–	660	600	1640	–	–	4x29
150/390HA	45	4	736	229	229	746	1656	411	474	406	330	265	290	–	660	600	1640	–	–	4x29
150/390HA	55	4	736	229	229	746	1675	411	474	406	330	265	320	–	730	670	1840	–	–	4x29
150/390HA	75	4	736	229	229	746	1851	411	474	406	330	265	320	–	730	670	1840	–	–	4x29
150/440HA	30	4	813	274	274	854	1556	411	474	432	381	265	290	–	660	600	1640	–	–	4x29
150/440HA	37	4	813	274	274	854	1656	411	474	432	381	265	290	–	660	600	1640	–	–	4x29
150/440HA	45	4	813	274	274	854	1656	411	474	432	381	265	290	–	660	600	1640	–	–	4x29
150/440HA	55	4	813	274	274	854	1675	411	474	432	381	265	320	–	730	670	1840	–	–	4x29
150/440HA	75	4	813	274	274	854	1851	411	474	432	381	265	320	–	730	670	1840	–	–	4x29
150/440HA	90	4	813	274	274	854	1851	411	474	432	381	265	320	–	730	670	1840	–	–	4x29
150/440HA	110	4	813	274	274	854	2101	411	474	432	381	265	320	–	730	670	1840	–	–	4x29
150/440HA	132	4	813	274	274	854	2211	411	474	432	381	265	320	–	730	670	1840	–	–	4x29
150/450HA	30	4	813	274	274	854	1556	411	474	432	381	265	290	–	660	600	1640	–	–	4x29
150/450HA	37	4	813	274	274	854	1656	411	474	432	381	265	290	–	660	600	1640	–	–	4x29
150/450HA	45	4	813	274	274	854	1656	411	474	432	381	265	290	–	660	600	1640	–	–	4x29
150/450HA	55	4	813	274	274	854	1675	411	474	432	381	265	320	–	730	670	1840	–	–	4x29
150/450HA	75	4	813	274	274	854	1851	411	474	432	381	265	320	–	730	670	1840	–	–	4x29
150/450HA	90	4	813	274	274	854	1851	411	474	432	381	265	320	–	730	670	1840	–	–	4x29
150/450HA	110	4	813	274	274	854	2101	411	474	432	381	265	370	–	860	790	2140	–	–	4x29
150/460DS	75	4	770	225	250	910	2238	607	665	440	330	320	320	–	730	670	1840	70	210	4x29
150/460DS	90	4	770	225	250	910	2238	607	665	440	330	320	320	–	730	670	1840	70	210	4x29
150/460DS	110	4	770	225	250	910	2488	607	665	440	330	320	370	–	860	790	2140	70	210	4x29
150/460DS	132	4	770	225	250	910	2598	607	665	440	330	320	370	–	860	790	2140	70	210	4x29
150/460DS	160	4	770	225	250	910	2434	607	665	440	330	320	370	–	860	790	2140	70	210	4x29
150/460DS	200	4	770	225	250	1017	2848	607	665	440	330	320	225	900	700	640	2250	70	210	6x24
150/530HA	55	4	890	320	320	958	1898	485	623	450	440	315	320	–	730	670	1840	–	–	4x29
150/530HA	75	4	890	320	320	958	2074	485	623	450	440	315	320	–	730	670	1840	–	–	4x29
150/530HA	90	4	890	320	320	958	2074	485	623	450	440	315	320	–	730	670	1840	–	–	4x29

Pumps with axially split housing

Single pumps (heating, air-conditioning, cooling and industry)



Dimensions, weights Wilo-SCP

Dimensions, weights

Wilo-SCP ...	Nominal motor power	Number of poles	Overall length	Dimensions																Pump flange dimensions n x Ø d _L			
	P ₂			–	l ₀	H ₃	H ₄	HP	L	L ₁	L ₂	L ₃	L ₄	S ₁	S ₂	S ₃	Sa	Se	SL		P ₅	P ₆	n x Ø d _L
	[kW]			–	[mm]																[pcs. x mm]		
150/530HA	110	4	890	320	320	958	2324	485	623	450	440	315	370	–	860	790	2140	–	–	4x29			
150/530HA	132	4	890	320	320	958	2434	485	623	450	440	315	370	–	860	790	2140	–	–	4x29			
150/530HA	160	4	890	320	320	958	2270	485	623	450	440	315	370	–	860	790	2140	–	–	4x29			
150/530HA	200	4	890	320	320	1065	2684	485	623	450	440	315	225	900	700	640	2250	–	–	6x24			
150/580HA	45	4	1090	328	328	943	1887	511	605	570	520	265	370	–	860	790	2140	–	–	4x29			
150/580HA	55	4	1090	328	328	943	1906	511	605	570	520	265	320	–	730	670	1840	–	–	4x29			
150/580HA	75	4	1090	328	328	943	2082	511	605	570	520	265	320	–	730	670	1840	–	–	4x29			
150/580HA	90	4	1090	328	328	943	2082	511	605	570	520	265	320	–	730	670	1840	–	–	4x29			
150/580HA	110	4	1090	328	328	943	2332	511	605	570	520	265	320	–	730	670	1840	–	–	4x29			
150/580HA	132	4	1090	328	328	943	2442	511	605	570	520	265	370	–	860	790	2140	–	–	4x29			
150/580HA	160	4	1090	328	328	943	2278	511	605	570	520	265	370	–	860	790	2140	–	–	4x29			
150/580HA	200	4	1090	328	328	1010	2692	511	605	570	520	265	350	–	830	790	2100	–	–	4x24			

Dimensions, weights

Wilo-SCP ...	Nominal motor power	Number of poles	Overall length	Dimensions																Pump flange dimensions n x Ø d _L			
	P ₂			–	l ₀	H ₃	H ₄	HP	L	L ₁	L ₂	L ₃	L ₄	S ₁	S ₂	S ₃	Sa	Se	SL		P ₅	P ₆	n x Ø d _L
	[kW]			–	[mm]																[pcs. x mm]		
200/310HA	18.5	4	724	227	227	736	1520	411	474	407	318	265	290	–	660	600	1640	–	–	4x29			
200/310HA	22	4	724	227	227	736	1520	411	474	407	318	265	290	–	660	600	1640	–	–	4x29			
200/310HA	30	4	724	227	227	736	1556	411	474	407	318	265	290	–	660	600	1640	–	–	4x29			
200/310HA	37	4	724	227	227	736	1656	411	474	407	318	265	290	–	660	600	1640	–	–	4x29			
200/310HA	45	4	724	227	227	736	1656	411	474	407	318	265	290	–	660	600	1640	–	–	4x29			
200/310HA	55	4	724	227	227	736	1675	411	474	407	318	265	320	–	730	670	1840	–	–	4x29			
200/320HA	22	4	750	248	248	839	1520	411	474	432	318	265	290	–	660	600	1640	–	–	4x29			
200/320HA	30	4	750	248	248	839	1556	411	474	432	318	265	290	–	660	600	1640	–	–	4x29			
200/320HA	37	4	750	248	248	839	1656	411	474	432	318	265	290	–	660	600	1640	–	–	4x29			
200/320HA	45	4	750	248	248	839	1656	411	474	432	318	265	290	–	660	600	1640	–	–	4x29			
200/320HA	55	4	750	248	248	839	1675	411	474	432	318	265	320	–	730	670	1840	–	–	4x29			
200/320HA	75	4	750	248	248	839	1851	411	474	432	318	265	320	–	730	670	1840	–	–	4x29			
200/360HA	37	4	790	285	285	918	1802	471	560	440	350	285	320	–	730	670	1840	–	–	4x29			
200/360HA	45	4	790	285	285	918	1802	471	560	440	350	285	320	–	730	670	1840	–	–	4x29			
200/360HA	55	4	790	285	285	918	1821	471	560	440	350	285	320	–	730	670	1840	–	–	4x29			
200/360HA	75	4	790	285	285	918	1997	471	560	440	350	285	320	–	730	670	1840	–	–	4x29			
200/360HA	90	4	790	285	285	918	1997	471	560	440	350	285	320	–	730	670	1840	–	–	4x29			
200/360HA	110	4	790	285	285	918	2247	471	560	440	350	285	320	–	730	670	1840	–	–	4x29			
200/360HB	37	4	820	276	276	893	1802	471	560	470	350	265	320	–	730	670	1840	–	–	4x29			
200/360HB	45	4	820	276	276	893	1802	471	560	470	350	265	320	–	730	670	1840	–	–	4x29			
200/360HB	55	4	820	276	276	893	1821	471	560	470	350	265	320	–	730	670	1840	–	–	4x29			

Pumps with axially split housing

Pumps with axially split housing

Single pumps (heating, air-conditioning, cooling and industry)

Dimensions, weights Wilo-SCP

Dimensions, weights																				
Wilo-SCP ...	Nominal motor power	Number of poles	Overall length	Dimensions																Pump flange dimensions
	P ₂			–	l ₀	H ₃	H ₄	HP	L	L ₁	L ₂	L ₃	L ₄	S ₁	S ₂	S ₃	Sa	Se	SL	P ₅
	[kW]	–	[mm]																[pcs. x mm]	
200/360HB	75	4	820	276	276	893	1997	471	560	470	350	265	320	–	730	670	1840	–	–	4x29
200/360HB	90	4	820	276	276	893	1997	471	560	470	350	265	320	–	730	670	1840	–	–	4x29
200/360HB	110	4	820	276	276	893	2247	471	560	470	350	265	320	–	730	670	1840	–	–	4x29
200/370HA	37	4	770	270	270	863	1801	470	560	420	350	245	320	–	730	670	1840	–	–	4x29
200/370HA	45	4	770	270	270	863	1801	470	560	420	350	245	320	–	730	670	1840	–	–	4x29
200/370HA	55	4	770	270	270	863	1820	470	560	420	350	245	320	–	730	670	1840	–	–	4x29
200/370HA	75	4	770	270	270	863	1996	470	560	420	350	245	320	–	730	670	1840	–	–	4x29
200/370HA	90	4	770	270	270	863	1996	470	560	420	350	245	320	–	730	670	1840	–	–	4x29
200/370HA	110	4	770	270	270	863	2246	470	560	420	350	245	320	–	730	670	1840	–	–	4x29
200/370HA	132	4	770	270	270	863	2356	470	560	420	350	245	370	–	860	790	2140	–	–	4x29
200/390HA	37	4	864	292	292	902	1908	525	612	483	381	265	290	–	660	600	1640	–	–	4x29
200/390HA	45	4	864	292	292	902	1908	525	612	483	381	265	290	–	660	600	1640	–	–	4x29
200/390HA	55	4	864	292	292	902	1927	525	612	483	381	265	320	–	730	670	1840	–	–	4x29
200/390HA	75	4	864	292	292	902	2103	525	612	483	381	265	320	–	730	670	1840	–	–	4x29
200/390HA	90	4	864	292	292	902	2103	525	612	483	381	265	320	–	730	670	1840	–	–	4x29
200/390HA	110	4	864	292	292	902	2353	525	612	483	381	265	320	–	730	670	1840	–	–	4x29
200/390HA	132	4	864	292	292	902	2463	525	612	483	381	265	370	–	860	790	2140	–	–	4x29
200/400HA	75	4	940	299	299	937	2103	525	612	483	458	265	320	–	730	670	1840	–	–	4x29
200/400HA	90	4	940	299	299	937	2103	525	612	483	458	265	320	–	730	670	1840	–	–	4x29
200/400HA	110	4	940	299	299	937	2353	525	612	483	458	265	320	–	730	670	1840	–	–	4x29
200/400HA	132	4	940	299	299	937	2463	525	612	483	458	265	370	–	860	790	2140	–	–	4x29
200/400HA	160	4	940	299	299	937	2299	525	612	483	458	265	370	–	860	790	2140	–	–	4x29
200/400HA	200	4	940	299	299	1004	2713	525	612	483	458	265	350	–	830	790	2100	–	–	4x24
200/440HA	45	4	840	300	300	918	1879	485	623	440	400	270	370	–	860	790	2140	–	–	4x29
200/440HA	55	4	840	300	300	918	1898	485	623	440	400	270	320	–	730	670	1840	–	–	4x29
200/440HA	75	4	840	300	300	918	2074	485	623	440	400	270	320	–	730	670	1840	–	–	4x29
200/440HA	90	4	840	300	300	918	2074	485	623	440	400	270	320	–	730	670	1840	–	–	4x29
200/440HA	110	4	840	300	300	918	2324	485	623	440	400	270	370	–	860	790	2140	–	–	4x29
200/440HA	132	4	840	300	300	918	2434	485	623	440	400	270	370	–	860	790	2140	–	–	4x29
200/440HA	160	4	840	300	300	918	2270	485	623	440	400	270	370	–	860	790	2140	–	–	4x29
200/460HA	55	4	940	299	299	937	1927	525	612	483	458	265	320	–	730	670	1840	–	–	4x29
200/460HA	75	4	940	299	299	937	2103	525	612	483	458	265	320	–	730	670	1840	–	–	4x29
200/460HA	90	4	940	299	299	937	2103	525	612	483	458	265	320	–	730	670	1840	–	–	4x29
200/460HA	110	4	940	299	299	937	2353	525	612	483	458	265	320	–	730	670	1840	–	–	4x29
200/460HA	132	4	940	299	299	937	2463	525	612	483	458	265	370	–	860	790	2140	–	–	4x29
200/460HA	160	4	940	299	299	937	2299	525	612	483	458	265	370	–	860	790	2140	–	–	4x29
200/460HA	200	4	940	299	299	1004	2713	525	612	483	458	265	350	–	830	790	2100	–	–	4x24
200/460HA	250	4	940	299	299	1004	2609	525	612	483	458	265	350	–	830	790	2100	–	–	4x24
200/480HA	75	4	927	343	343	957	2103	525	612	470	457	265	320	–	730	670	1840	–	–	4x29
200/480HA	90	4	927	343	343	957	2103	525	612	470	457	265	320	–	730	670	1840	–	–	4x29
200/480HA	110	4	927	343	343	957	2353	525	612	470	457	265	320	–	730	670	1840	–	–	4x29

Pumps with axially split housing

Single pumps (heating, air-conditioning, cooling and industry)



Dimensions, weights Wilo-SCP

Dimensions, weights

Wilo-SCP ...	Nominal motor power	Number of poles	Overall length	Dimensions																Pump flange dimensions
				P ₂	–	l ₀	H ₃	H ₄	HP	L	L ₁	L ₂	L ₃	L ₄	S ₁	S ₂	S ₃	Sa	Se	
	[kW]	–	[mm]																[pcs. x mm]	
200/480HA	132	4	927	343	343	957	2463	525	612	470	457	265	370	–	860	790	2140	–	–	4x29
200/480HA	160	4	927	343	343	957	2299	525	612	470	457	265	370	–	860	790	2140	–	–	4x29
200/480HA	200	4	927	343	343	1024	2713	525	612	470	457	265	350	–	830	790	2100	–	–	4x24
200/550HA	90	4	927	343	343	957	2103	525	612	470	457	265	320	–	730	670	1840	–	–	4x29
200/550HA	110	4	927	343	343	957	2353	525	612	470	457	265	320	–	730	670	1840	–	–	4x29
200/550HA	132	4	927	343	343	957	2463	525	612	470	457	265	370	–	860	790	2140	–	–	4x29
200/550HA	160	4	927	343	343	957	2299	525	612	470	457	265	370	–	860	790	2140	–	–	4x29
200/550HA	200	4	927	343	343	1024	2713	525	612	470	457	265	350	–	830	790	2100	–	–	4x24
200/550HA	250	4	927	343	343	1024	2609	525	612	470	457	265	350	–	830	790	2100	–	–	4x24
200/550HA	315	4	927	343	343	1024	2609	525	612	470	457	265	350	–	830	790	2100	–	–	4x24
200/560HA	160	4	979	356	356	1064	2449	594	693	521	458	355	370	–	860	790	2140	–	–	4x29
200/560HA	200	4	979	356	356	1171	2863	594	693	521	458	355	225	900	700	640	2250	–	–	6x24
200/560HA	250	4	979	356	356	1171	2759	594	693	521	458	355	225	900	800	740	2250	–	–	6x24
200/560HA	315	4	979	356	356	1171	2759	594	693	521	458	355	225	900	800	740	2250	–	–	6x24
200/660DV	110	4	1100	440	440	1330	2474	565	693	600	500	340	250	–	790	730	2000	–	–	4x29
200/660DV	132	4	1100	440	440	1290	2584	565	693	600	500	340	350	–	830	790	2100	–	–	4x24
200/660DV	160	4	1100	440	440	1330	2420	565	693	600	500	340	250	–	790	730	2000	–	–	4x29
200/660DV	200	4	1100	440	440	1330	2834	565	693	600	500	340	225	900	800	740	2250	–	–	6x24
200/660DV	250	4	1100	440	440	1330	2730	565	693	600	500	340	225	900	800	740	2250	–	–	6x24
200/660DV	315	4	1100	440	440	1330	2730	565	693	600	500	340	225	900	800	740	2250	–	–	6x24
200/660DV	355	4	1100	440	440	1330	3099	565	693	600	500	340	250	1000	790	730	2500	–	–	6x29
200/660DV	400	4	1100	440	440	1330	3099	565	693	600	500	340	250	1000	790	730	2500	–	–	6x29
200/660DV	450	4	1100	440	440	1330	3344	565	693	600	500	340	280	1120	790	730	2800	–	–	6x29
250/250HA	15	4	630	222	222	778	1450	385	473	370	260	265	250	–	610	550	1440	–	–	4x29
250/250HA	18.5	4	630	222	222	778	1493	385	473	370	260	265	250	–	610	550	1440	–	–	4x29
250/250HA	22	4	630	222	222	778	1493	385	473	370	260	265	250	–	610	550	1440	–	–	4x29
250/250HA	30	4	630	222	222	778	1529	385	473	370	260	265	250	–	610	550	1440	–	–	4x29
250/250HA	37	4	630	222	222	778	1629	385	473	370	260	265	250	–	610	550	1440	–	–	4x29
250/330HA	45	4	845	273	273	917	1908	525	612	508	337	315	290	–	660	600	1640	–	–	4x29
250/330HA	55	4	845	273	273	917	1927	525	612	508	337	315	320	–	730	670	1840	–	–	4x29
250/330HA	75	4	845	273	273	917	2103	525	612	508	337	315	320	–	730	670	1840	–	–	4x29
250/330HA	90	4	845	273	273	917	2103	525	612	508	337	315	320	–	730	670	1840	–	–	4x29
250/330HA	110	4	845	273	273	917	2353	525	612	508	337	315	370	–	860	790	2140	–	–	4x29
250/360HA	37	4	897	320	320	1003	1879	485	623	517	380	315	290	–	660	600	1640	–	–	4x29
250/360HA	45	4	897	320	320	1003	1879	485	623	517	380	315	320	–	730	670	1840	–	–	4x29
250/360HA	55	4	897	320	320	1003	1898	485	623	517	380	315	320	–	730	670	1840	–	–	4x29
250/360HA	75	4	897	320	320	1003	2074	485	623	517	380	315	320	–	730	670	1840	–	–	4x29
250/360HA	90	4	897	320	320	1003	2074	485	623	517	380	315	320	–	730	670	1840	–	–	4x29
250/360HA	110	4	897	320	320	1003	2324	485	623	517	380	315	370	–	860	790	2140	–	–	4x29
250/390HA	90	4	897	320	320	1003	2074	485	623	517	380	315	320	–	730	670	1840	–	–	4x29
250/390HA	110	4	897	320	320	1003	2324	485	623	517	380	315	370	–	860	790	2140	–	–	4x29

Pumps with axially split housing

Pumps with axially split housing

Single pumps (heating, air-conditioning, cooling and industry)

Dimensions, weights Wilo-SCP

Dimensions, weights																				
Wilo-SCP ...	Nominal motor power	Number of poles	Overall length	Dimensions																Pump flange dimensions
	P ₂			–	l ₀	H ₃	H ₄	HP	L	L ₁	L ₂	L ₃	L ₄	S ₁	S ₂	S ₃	Sa	Se	SL	P ₅
	[kW]	–	[mm]																[pcs. x mm]	
250/390HA	132	4	897	320	320	1003	2434	485	623	517	380	315	370	–	860	790	2140	–	–	4x29
250/390HA	160	4	897	320	320	1003	2270	485	623	517	380	315	370	–	860	790	2140	–	–	4x29
250/390HA	200	4	897	320	320	1110	2684	485	623	517	380	315	225	900	700	640	2250	–	–	6x24
250/390HA	250	4	897	320	320	1110	2580	485	623	517	380	315	225	900	800	740	2250	–	–	6x24
250/450HA	110	4	991	343	343	1049	2503	594	693	534	457	355	370	–	860	790	2140	–	–	4x29
250/450HA	132	4	991	343	343	1049	2613	594	693	534	457	355	370	–	860	790	2140	–	–	4x29
250/450HA	160	4	991	343	343	1049	2449	594	693	534	457	355	370	–	860	790	2140	–	–	4x29
250/450HA	200	4	991	343	343	1156	2863	594	693	534	457	355	225	900	700	640	2250	–	–	6x24
250/450HA	250	4	991	343	343	1156	2759	594	693	534	457	355	225	900	800	740	2250	–	–	6x24
250/450HA	315	4	991	343	343	1156	2759	594	693	534	457	355	225	900	800	740	2250	–	–	6x24
250/570HA	200	4	1076	356	356	1191	2863	594	693	584	492	355	225	900	700	640	2250	–	–	6x24
250/570HA	250	4	1076	356	356	1191	2759	594	693	584	492	355	225	900	800	740	2250	–	–	6x24
250/570HA	315	4	1076	356	356	1191	2759	594	693	584	492	355	225	900	800	740	2250	–	–	6x24
250/570HA	355	4	1076	356	356	1191	3128	594	693	584	492	355	250	1000	670	610	2500	–	–	6x29
250/570HA	400	4	1076	356	356	1191	3128	594	693	584	492	355	250	1000	670	610	2500	–	–	6x29
250/570HA	450	4	1076	356	356	1191	3373	594	693	584	492	355	280	1120	790	730	2800	–	–	6x29
250/570HA	500	4	1076	356	356	1191	3373	594	693	584	492	355	280	1120	790	730	2800	–	–	6x29
250/570HA	560	4	1076	356	356	1191	3373	594	693	584	492	355	280	1120	790	730	2800	–	–	6x29
250/570HA	630	4	1076	356	356	1221	3393	594	693	584	492	355	250	1050	870	800	2600	–	–	6x29
250/700DV	315	4	1194	407	407	1328	3000	704	825	635	559	350	250	1000	790	730	2500	–	–	6x29
250/700DV	355	4	1194	407	407	1328	3369	704	825	635	559	350	280	1020	790	730	2600	–	–	6x29
250/700DV	400	4	1194	407	407	1328	3369	704	825	635	559	350	280	1020	790	730	2600	–	–	6x29
250/700DV	450	4	1194	407	407	1358	3614	704	825	635	559	350	250	1225	780	710	2950	–	–	6x29
250/700DV	500	4	1194	407	407	1358	3614	704	825	635	559	350	250	1225	780	710	2950	–	–	6x29
250/700DV	560	4	1194	407	407	1358	3614	704	825	635	559	350	250	1225	780	710	2950	–	–	6x29
250/700DV	630	4	1194	407	407	1358	3634	704	825	635	559	350	250	1100	870	800	2700	–	–	6x29
250/740DV	400	4	1194	407	407	1328	3369	704	825	635	559	350	280	1020	790	730	2600	–	–	6x29
250/740DV	450	4	1194	407	407	1358	3614	704	825	635	559	350	250	1225	780	710	2950	–	–	6x29
250/740DV	500	4	1194	407	407	1358	3614	704	825	635	559	350	250	1225	780	710	2950	–	–	6x29
250/740DV	560	4	1194	407	407	1358	3614	704	825	635	559	350	250	1225	780	710	2950	–	–	6x29
250/740DV	630	4	1194	407	407	1358	3634	704	825	635	559	350	250	1100	870	800	2700	–	–	6x29

Dimensions, weights																				
Wilo-SCP ...	Nominal motor power	Number of poles	Over-all length	Dimensions																Pump flange dimensions
	P ₂			–	l ₀	H ₃	H ₄	HP	L	L ₁	L ₂	L ₃	L ₄	S ₁	S ₂	S ₃	Sa	Se	SL	P ₅
	[kW]	–	[mm]																[pcs. x mm]	
400/480HA	110	6	1335	445	445	1560	2507	602	743	790	545	530	250	900	870	800	2300	–	–	6x29
400/480HA	132	6	1335	445	445	1560	2507	602	743	790	545	530	250	900	870	800	2300	–	–	6x29

Pumps with axially split housing

Single pumps (heating, air-conditioning, cooling and industry)



Dimensions, weights Wilo-SCP

Dimensions, weights

Wilo-SCP ...	Nominal motor power	Number of poles	Over-all length	Dimensions																Pump flange dimensions n x Ø d _L			
	P ₂			–	l ₀	H ₃	H ₄	HP	L	L ₁	L ₂	L ₃	L ₄	S ₁	S ₂	S ₃	Sa	Se	SL		P ₅	P ₆	n x Ø d _L
	[kW]			–	[mm]																[pcs. x mm]		
400/480HA	160	6	1335	445	445	1530	2817	602	743	790	545	530	250	1000	890	830	2500	–	–	6x29			
400/480HA	200	6	1335	445	445	1530	2817	602	743	790	545	530	250	1000	890	830	2500	–	–	6x29			
400/540HA	90	6	1067	428	428	1160	2572	625	785	635	432	550	250	900	670	610	2300	–	–	6x29			
400/540HA	110	6	1067	428	428	1160	2572	625	785	635	432	550	250	900	670	610	2300	–	–	6x29			
400/540HA	132	6	1067	428	428	1160	2572	625	785	635	432	550	250	900	670	610	2300	–	–	6x29			
400/540HA	160	6	1067	428	428	1160	2882	625	785	635	432	550	280	1020	790	730	2600	–	–	6x29			
400/540HA	200	6	1067	428	428	1160	2882	625	785	635	432	550	280	1020	790	730	2600	–	–	6x29			
400/540HA	250	6	1067	428	428	1160	2882	625	785	635	432	550	280	1020	790	730	2600	–	–	6x29			
400/540HA	315	6	1067	428	428	1160	2882	625	785	635	432	550	280	1020	790	730	2600	–	–	6x29			
400/550HA	160	6	1320	470	470	1535	2969	667	830	760	560	530	250	1050	870	800	2600	–	–	6x29			
400/550HA	200	6	1320	470	470	1535	2969	667	830	760	560	530	250	1050	870	800	2600	–	–	6x29			
400/550HA	250	6	1320	470	470	1535	2969	667	830	760	560	530	250	1050	870	800	2600	–	–	6x29			
400/550HA	315	6	1320	470	470	1535	2969	667	830	760	560	530	250	1050	870	800	2600	–	–	6x29			
400/660DV	315	4	1422	483	483	1570	3246	815	959	762	660	500	280	1120	890	830	2800	–	–	6x29			
400/660DV	355	4	1422	483	483	1600	3615	815	959	762	660	500	250	1250	870	800	3000	–	–	6x29			
400/660DV	400	4	1422	483	483	1600	3615	815	959	762	660	500	250	1250	870	800	3000	–	–	6x29			
400/660DV	450	4	1422	483	483	1600	3860	815	959	762	660	500	250	1350	870	800	3200	–	–	6x29			
400/660DV	500	4	1422	483	483	1600	3860	815	959	762	660	500	250	1350	870	800	3200	–	–	6x29			
400/660DV	560	4	1422	483	483	1600	3860	815	959	762	660	500	250	1350	870	800	3200	–	–	6x29			
400/660DV	630	4	1422	483	483	1600	3880	815	959	762	660	500	250	1250	870	800	3000	–	–	6x29			
400/690HA	250	6	1546	500	500	1575	2969	667	830	824	722	460	250	1000	1060	1000	2500	–	–	6x29			
400/690HA	315	6	1546	500	500	1575	2969	667	830	824	722	460	250	1000	1060	1000	2500	–	–	6x29			
400/690HA	355	6	1546	500	500	1605	3583	667	830	824	722	460	250	1270	1060	990	3040	–	–	6x29			
400/690HA	400	6	1546	500	500	1605	3583	667	830	824	722	460	250	1270	1060	990	3040	–	–	6x29			
400/690HA	450	6	1546	500	500	1605	3603	667	830	824	722	460	250	1200	1060	990	2900	–	–	6x29			
400/690HA	500	6	1546	500	500	1605	3933	667	830	824	722	460	250	1270	1060	990	3040	–	–	6x29			
400/690HA	560	6	1546	500	500	1605	3933	667	830	824	722	460	250	1270	1060	990	3040	–	–	6x29			
400/690HA	630	6	1546	500	500	1605	3933	667	830	824	722	460	250	1270	1060	990	3040	–	–	6x29			
400/710HA	200	6	1626	521	521	1610	3000	704	825	864	762	460	250	1000	1060	1000	2500	–	–	6x29			
400/710HA	250	6	1626	521	521	1610	3000	704	825	864	762	460	250	1000	1060	1000	2500	–	–	6x29			
400/710HA	315	6	1626	521	521	1610	3000	704	825	864	762	460	250	1000	1060	1000	2500	–	–	6x29			
400/710HA	355	6	1626	521	521	1640	3614	704	825	864	762	460	250	1270	1060	990	3040	–	–	6x29			
400/710HA	400	6	1626	521	521	1640	3614	704	825	864	762	460	250	1270	1060	990	3040	–	–	6x29			
400/710HA	450	6	1626	521	521	1640	3634	704	825	864	762	460	250	1200	1060	990	2900	–	–	6x29			
400/710HA	500	6	1626	521	521	1640	3964	704	825	864	762	460	250	1270	1060	990	3040	–	–	6x29			
400/710HA	560	6	1626	521	521	1640	3964	704	825	864	762	460	250	1270	1060	990	3040	–	–	6x29			
400/710HA	630	6	1626	521	521	1640	3964	704	825	864	762	460	250	1270	1060	990	3040	–	–	6x29			

Pumps with axially split housing

Pumps with axially split housing

Single pumps (heating, air-conditioning, cooling and industry)

Dimensions, weights Wilo-SCP

Dimensions, weights							
Wilo-SCP ...	Nominal motor power	Number of poles	Nominal diameter		Flanges		Weight approx.
	P ₂	–	DN ₂	DN ₁	PN ₁	PN ₂	M
	[kW]	–	[mm]		–		[kg]
50/180HA	1.1	4	50	80	16	16	150
50/180HA	1.5	4	50	80	16	16	152
50/220HA	1.1	4	50	65	16	16	123
50/220HA	1.5	4	50	65	16	16	125
50/220HA	2.2	4	50	65	16	16	131
50/340HA	3	4	50	80	16	16	209
50/340HA	4	4	50	80	16	16	216
50/340HA	5.5	4	50	80	16	16	224
50/340HA	7.5	4	50	80	16	16	257
50/340HA	11	4	50	80	16	16	306
50/340DS	5.5	4	50	80	16	16	372
50/340DS	7.5	4	50	80	16	16	426
50/340DS	11	4	50	80	16	16	442
50/340DS	15	4	50	80	16	16	486
50/340DS	18.5	4	50	80	16	16	515
50/340DS	22	4	50	80	16	16	528
50/340DS	30	4	50	80	16	16	577
65/390HS	5.5	4	65	80	16	16	256
65/390HS	7.5	4	65	80	16	16	277
65/390HS	11	4	65	80	16	16	326
65/390HS	15	4	65	80	16	16	340
65/390HS	18.5	4	65	80	16	16	369
65/390HS	22	4	65	80	16	16	378
80/200HA	11	2	80	100	16	16	304
80/200HA	15	2	80	100	16	16	319
80/200HA	18.5	2	80	100	16	16	325
80/200HA	22	2	80	100	16	16	340
80/230HA	1.5	4	80	100	16	16	205
80/230HA	2.2	4	80	100	16	16	211
80/230HA	3	4	80	100	16	16	214
80/230HA	4	4	80	100	16	16	221
80/230HA	5.5	4	80	100	16	16	242
80/340HA	4	4	80	100	16	16	221
80/340HA	5.5	4	80	100	16	16	241
80/340HA	7.5	4	80	100	16	16	262
80/340HA	11	4	80	100	16	16	311
80/340HA	15	4	80	100	16	16	355
80/340HA	18.5	4	80	100	16	16	354
80/360DS	15	4	80	100	16	16	465
80/360DS	18.5	4	80	100	16	16	494
80/360DS	22	4	80	100	16	16	507
80/360DS	30	4	80	100	16	16	556
80/360DS	37	4	80	100	16	16	603

Pumps with axially split housing

Single pumps (heating, air-conditioning, cooling and industry)



Dimensions, weights Wilo-SCP

Dimensions, weights							
Wilo-SCP ...	Nominal motor power	Number of poles	Nominal diameter		Flanges		Weight approx.
	P ₂		DN ₂	DN ₁	PN ₁	PN ₂	M
	[kW]	–	[mm]		–		[kg]
80/360DS	45	4	80	100	16	16	640
80/380DS	7.5	4	80	100	16	16	432
80/380DS	11	4	80	100	16	16	478
80/380DS	15	4	80	100	16	16	537
80/380DS	18.5	4	80	100	16	16	521
80/380DS	22	4	80	100	16	16	579
80/380DS	30	4	80	100	16	16	628
80/380DS	37	4	80	100	16	16	675
100/270HA	4	4	100	125	16	16	291
100/270HA	5.5	4	100	125	16	16	299
100/270HA	7.5	4	100	125	16	16	320
100/270HA	11	4	100	125	16	16	336
100/280HA	4	4	100	125	16	16	261
100/280HA	5.5	4	100	125	16	16	269
100/280HA	7.5	4	100	125	16	16	290
100/280HA	11	4	100	125	16	16	306
100/280HA	15	4	100	125	16	16	350
100/280HA	18.5	4	100	125	16	16	379
100/340DS	18.5	4	100	125	16	16	606
100/340DS	22	4	100	125	16	16	619
100/340DS	30	4	100	125	16	16	668
100/340DS	37	4	100	125	16	16	715
100/340DS	45	4	100	125	16	16	752
100/340DS	55	4	100	125	16	16	902
100/360HA	5.5	4	100	125	16	16	286
100/360HA	7.5	4	100	125	16	16	307
100/360HA	11	4	100	125	16	16	323
100/360HA	15	4	100	125	16	16	367
100/360HA	18.5	4	100	125	16	16	396
100/360HA	22	4	100	125	16	16	409
100/360HA	30	4	100	125	16	16	458
100/400HA	15	4	100	125	16	16	367
100/400HA	18.5	4	100	125	16	16	396
100/400HA	22	4	100	125	16	16	409
100/400HA	30	4	100	125	16	16	458
100/400HA	37	4	100	125	16	16	550
100/400HA	45	4	100	125	16	16	587
100/400HA	55	4	100	125	16	16	646
100/410DS	22	4	100	125	16	16	562
100/410DS	30	4	100	125	16	16	611
100/410DS	37	4	100	125	16	16	658
100/410DS	45	4	100	125	16	16	695
100/410DS	55	4	100	125	16	16	845

Pumps with axially split housing

Single pumps (heating, air-conditioning, cooling and industry)

Dimensions, weights Wilo-SCP

Dimensions, weights							
Wilo-SCP ...	Nominal motor power	Number of poles	Nominal diameter		Flanges		Weight approx.
	P ₂	–	DN ₂	DN ₁	PN ₁	PN ₂	M
	[kW]	–	[mm]		–		[kg]
100/410DS	75	4	100	125	16	16	1080
100/410DS	90	4	100	125	16	16	1131
125/290HA	7.5	4	125	150	16	16	320
125/290HA	11	4	125	150	16	16	366
125/290HA	15	4	125	150	16	16	380
125/290HA	18.5	4	125	150	16	16	409
125/290HA	22	4	125	150	16	16	422
125/330HA	15	4	125	150	16	16	410
125/330HA	18.5	4	125	150	16	16	439
125/330HA	22	4	125	150	16	16	452
125/330HA	30	4	125	150	16	16	546
125/330HA	37	4	125	150	16	16	593
125/330HA	45	4	125	150	16	16	630
125/440HA	22	4	125	150	16	16	566
125/440HA	30	4	125	150	16	16	615
125/440HA	37	4	125	150	16	16	662
125/440HA	45	4	125	150	16	16	699
125/440HA	55	4	125	150	16	16	810
125/440HA	75	4	125	150	16	16	1045
125/440HA	90	4	125	150	16	16	1096
125/440HA	110	4	125	150	16	16	1527
125/460DS	37	4	125	150	16	16	1006
125/460DS	45	4	125	150	16	16	1043
125/460DS	55	4	125	150	16	16	1063
125/460DS	75	4	125	150	16	16	1298
125/460DS	90	4	125	150	16	16	1349
125/460DS	110	4	125	150	16	16	1720
125/460DS	132	4	125	150	16	16	1808
125/460DS	160	4	125	150	16	16	1883
125/460DS	200	4	125	150	16	16	2638
125/470HA	37	4	125	150	16	16	1033
125/470HA	45	4	125	150	16	16	1070
125/470HA	55	4	125	150	16	16	1090
125/470HA	75	4	125	150	16	16	1325
125/470HA	90	4	125	150	16	16	1376
125/470HA	110	4	125	150	16	16	1747
125/470HA	132	4	125	150	16	16	1885
150/290HA	15	4	150	200	16	16	615
150/290HA	18.5	4	150	200	16	16	645
150/290HA	22	4	150	200	16	16	657
150/290HA	30	4	150	200	16	16	706
150/290HA	37	4	150	200	16	16	753
150/350HA	30	4	150	200	16	16	846

Pumps with axially split housing

Single pumps (heating, air-conditioning, cooling and industry)



Dimensions, weights Wilo-SCP

Dimensions, weights

Wilo-SCP ...	Nominal motor power	Number of poles	Nominal diameter		Flanges		Weight approx. M
	P ₂		DN ₂	DN ₁	PN ₁	PN ₂	
	[kW]	–	[mm]		–		[kg]
150/350HA	37	4	150	200	16	16	893
150/350HA	45	4	150	200	16	16	930
150/350HA	55	4	150	200	16	16	950
150/350HA	75	4	150	200	16	16	1185
150/390HA	18.5	4	150	200	16	16	638
150/390HA	22	4	150	200	16	16	651
150/390HA	30	4	150	200	16	16	700
150/390HA	37	4	150	200	16	16	747
150/390HA	45	4	150	200	16	16	784
150/390HA	55	4	150	200	16	16	895
150/390HA	75	4	150	200	16	16	1130
150/440HA	30	4	150	200	16	16	755
150/440HA	37	4	150	200	16	16	802
150/440HA	45	4	150	200	16	16	839
150/440HA	55	4	150	200	16	16	950
150/440HA	75	4	150	200	16	16	1185
150/440HA	90	4	150	200	16	16	1236
150/440HA	110	4	150	200	16	16	1607
150/440HA	132	4	150	200	16	16	1695
150/450HA	30	4	150	200	16	16	755
150/450HA	37	4	150	200	16	16	802
150/450HA	45	4	150	200	16	16	839
150/450HA	55	4	150	200	16	16	950
150/450HA	75	4	150	200	16	16	1185
150/450HA	90	4	150	200	16	16	1236
150/450HA	110	4	150	200	16	16	1643
150/460DS	75	4	150	200	16	16	1485
150/460DS	90	4	150	200	16	16	1536
150/460DS	110	4	150	200	16	16	1957
150/460DS	132	4	150	200	16	16	2045
150/460DS	160	4	150	200	16	16	2120
150/460DS	200	4	150	200	16	16	2845
150/530HA	55	4	150	200	16	16	1157
150/530HA	75	4	150	200	16	16	1392
150/530HA	90	4	150	200	16	16	1443
150/530HA	110	4	150	200	16	16	1864
150/530HA	132	4	150	200	16	16	1952
150/530HA	160	4	150	200	16	16	2027
150/530HA	200	4	150	200	16	16	2752
150/580HA	45	4	150	200	16	16	1200
150/580HA	55	4	150	200	16	16	1170
150/580HA	75	4	150	200	16	16	1405
150/580HA	90	4	150	200	16	16	1456

Pumps with axially split housing

Single pumps (heating, air-conditioning, cooling and industry)

Dimensions, weights Wilo-SCP

Dimensions, weights							
Wilo-SCP ...	Nominal motor power	Number of poles	Nominal diameter		Flanges		Weight approx.
	P ₂	–	DN ₂	DN ₁	PN ₁	PN ₂	M
	[kW]	–	[mm]		–		[kg]
150/580HA	110	4	150	200	16	16	1827
150/580HA	132	4	150	200	16	16	1965
150/580HA	160	4	150	200	16	16	2040
150/580HA	200	4	150	200	16	16	2735
200/310HA	18.5	4	200	200	16	16	676
200/310HA	22	4	200	200	16	16	689
200/310HA	30	4	200	200	16	16	738
200/310HA	37	4	200	200	16	16	785
200/310HA	45	4	200	200	16	16	822
200/310HA	55	4	200	200	16	16	933
200/320HA	22	4	200	250	16	16	731
200/320HA	30	4	200	250	16	16	780
200/320HA	37	4	200	250	16	16	827
200/320HA	45	4	200	250	16	16	864
200/320HA	55	4	200	250	16	16	975
200/320HA	75	4	200	250	16	16	1210
200/360HA	37	4	200	250	16	16	1053
200/360HA	45	4	200	250	16	16	1090
200/360HA	55	4	200	250	16	16	1110
200/360HA	75	4	200	250	16	16	1345
200/360HA	90	4	200	250	16	16	1396
200/360HA	110	4	200	250	16	16	1767
200/360HB	37	4	200	300	16	16	993
200/360HB	45	4	200	300	16	16	1030
200/360HB	55	4	200	300	16	16	1050
200/360HB	75	4	200	300	16	16	1285
200/360HB	90	4	200	300	16	16	1336
200/360HB	110	4	200	300	16	16	1707
200/370HA	37	4	200	200	16	16	1008
200/370HA	45	4	200	200	16	16	1045
200/370HA	55	4	200	200	16	16	1065
200/370HA	75	4	200	200	16	16	1300
200/370HA	90	4	200	200	16	16	1351
200/370HA	110	4	200	200	16	16	1722
200/370HA	132	4	200	200	16	16	1860
200/390HA	37	4	200	250	16	16	1021
200/390HA	45	4	200	250	16	16	1058
200/390HA	55	4	200	250	16	16	1169
200/390HA	75	4	200	250	16	16	1404
200/390HA	90	4	200	250	16	16	1455
200/390HA	110	4	200	250	16	16	1826
200/390HA	132	4	200	250	16	16	1964
200/400HA	75	4	200	250	16	16	1575

Pumps with axially split housing

Single pumps (heating, air-conditioning, cooling and industry)



Dimensions, weights Wilo-SCP

Dimensions, weights							
Wilo-SCP ...	Nominal motor power	Number of poles	Nominal diameter		Flanges		Weight approx.
	P ₂		DN ₂	DN ₁	PN ₁	PN ₂	M
	[kW]	–	[mm]		–		[kg]
200/400HA	90	4	200	250	16	16	1626
200/400HA	110	4	200	250	16	16	1997
200/400HA	132	4	200	250	16	16	2135
200/400HA	160	4	200	250	16	16	2210
200/400HA	200	4	200	250	16	16	2905
200/440HA	45	4	200	250	16	16	1080
200/440HA	55	4	200	250	16	16	1050
200/440HA	75	4	200	250	16	16	1285
200/440HA	90	4	200	250	16	16	1336
200/440HA	110	4	200	250	16	16	1757
200/440HA	132	4	200	250	16	16	1845
200/440HA	160	4	200	250	16	16	1920
200/460HA	55	4	200	250	16	16	1340
200/460HA	75	4	200	250	16	16	1575
200/460HA	90	4	200	250	16	16	1626
200/460HA	110	4	200	250	16	16	1997
200/460HA	132	4	200	250	16	16	2135
200/460HA	160	4	200	250	16	16	2210
200/460HA	200	4	200	250	16	16	2905
200/460HA	250	4	200	250	16	16	2740
200/480HA	75	4	200	200	16	16	1524
200/480HA	90	4	200	200	16	16	1575
200/480HA	110	4	200	200	16	16	1946
200/480HA	132	4	200	200	16	16	2084
200/480HA	160	4	200	200	16	16	2159
200/480HA	200	4	200	200	16	16	2854
200/550HA	90	4	200	200	16	16	1575
200/550HA	110	4	200	200	16	16	1946
200/550HA	132	4	200	200	16	16	2084
200/550HA	160	4	200	200	16	16	2159
200/550HA	200	4	200	200	16	16	2854
200/550HA	250	4	200	200	16	16	2689
200/550HA	315	4	200	200	16	16	2894
200/560HA	160	4	200	250	16	16	2230
200/560HA	200	4	200	250	16	16	2955
200/560HA	250	4	200	250	16	16	2811
200/560HA	315	4	200	250	16	16	3007
200/660DV	110	4	200	250	16	16	2417
200/660DV	132	4	200	250	16	16	2485
200/660DV	160	4	200	250	16	16	2580
200/660DV	200	4	200	250	16	16	3305
200/660DV	250	4	200	250	16	16	3140
200/660DV	315	4	200	250	16	16	3345

Pumps with axially split housing

Single pumps (heating, air-conditioning, cooling and industry)

Dimensions, weights Wilo-SCP

Dimensions, weights							
Wilo-SCP ...	Nominal motor power	Number of poles	Nominal diameter		Flanges		Weight approx.
	P ₂	–	DN ₂	DN ₁	PN ₁	PN ₂	M
	[kW]	–	[mm]		–		[kg]
200/660DV	355	4	200	250	16	16	3305
200/660DV	400	4	200	250	16	16	3405
200/660DV	450	4	200	250	16	16	3840
250/250HA	15	4	250	250	16	16	535
250/250HA	18.5	4	250	250	16	16	564
250/250HA	22	4	250	250	16	16	577
250/250HA	30	4	250	250	16	16	626
250/250HA	37	4	250	250	16	16	674
250/330HA	45	4	250	300	16	16	1265
250/330HA	55	4	250	300	16	16	1376
250/330HA	75	4	250	300	16	16	1611
250/330HA	90	4	250	300	16	16	1662
250/330HA	110	4	250	300	16	16	2083
250/360HA	37	4	250	300	16	16	982
250/360HA	45	4	250	300	16	16	1110
250/360HA	55	4	250	300	16	16	1130
250/360HA	75	4	250	300	16	16	1365
250/360HA	90	4	250	300	16	16	1416
250/360HA	110	4	250	300	16	16	1837
250/390HA	90	4	250	300	16	16	1416
250/390HA	110	4	250	300	16	16	1837
250/390HA	132	4	250	300	16	16	1925
250/390HA	160	4	250	300	16	16	2000
250/390HA	200	4	250	300	16	16	2725
250/390HA	250	4	250	300	16	16	2580
250/450HA	110	4	250	300	16	16	2203
250/450HA	132	4	250	300	16	16	2291
250/450HA	160	4	250	300	16	16	2366
250/450HA	200	4	250	300	16	16	3091
250/450HA	250	4	250	300	16	16	2946
250/450HA	315	4	250	300	16	16	3151
250/570HA	200	4	250	300	16	16	3160
250/570HA	250	4	250	300	16	16	3015
250/570HA	315	4	250	300	16	16	3220
250/570HA	355	4	250	300	16	16	3170
250/570HA	400	4	250	300	16	16	3270
250/570HA	450	4	250	300	16	16	3715
250/570HA	500	4	250	300	16	16	3825
250/570HA	560	4	250	300	16	16	4090
250/570HA	630	4	250	300	16	16	5113
250/700DV	315	4	250	300	25	25	3695
250/700DV	355	4	250	300	25	25	3720
250/700DV	400	4	250	300	25	25	3820

Pumps with axially split housing

Single pumps (heating, air-conditioning, cooling and industry)



Dimensions, weights Wilo-SCP

Dimensions, weights

Wilo-SCP ...	Nominal motor power	Number of poles	Nominal diameter		Flanges		Weight approx. M [kg]
	P ₂		DN ₂	DN ₁	PN ₁	PN ₂	
	[kW]		[mm]		-		
250/700DV	450	4	250	300	25	25	4319
250/700DV	500	4	250	300	25	25	4429
250/700DV	560	4	250	300	25	25	4694
250/700DV	630	4	250	300	25	25	5618
250/740DV	400	4	250	300	16	16	3820
250/740DV	450	4	250	300	16	16	4319
250/740DV	500	4	250	300	16	16	4429
250/740DV	560	4	250	300	16	16	4694
250/740DV	630	4	250	300	16	16	5618
300/330HA	75	4	300	350	16	16	1625
300/330HA	90	4	300	350	16	16	1676
300/330HA	110	4	300	350	16	16	2097
300/330HA	132	4	300	350	16	16	2185
300/330HB	55	4	300	350	16	16	1193
300/330HB	75	4	300	350	16	16	1428
300/330HB	90	4	300	350	16	16	1479
300/330HB	110	4	300	350	16	16	1900
300/330HB	132	4	300	350	16	16	1988
300/380HA	110	4	300	350	16	16	2313
300/380HA	132	4	300	350	16	16	2401
300/380HA	160	4	300	350	16	16	2476
300/380HA	200	4	300	350	16	16	3201
300/380HA	250	4	300	350	16	16	3056
300/400HA	110	4	300	400	16	16	2177
300/400HA	132	4	300	400	16	16	2265
300/400HA	160	4	300	400	16	16	2340
300/400HA	200	4	300	400	16	16	3065
300/400HA	250	4	300	400	16	16	2920
300/490HA	110	4	300	350	16	16	2407
300/490HA	132	4	300	350	16	16	2495
300/490HA	160	4	300	350	16	16	2570
300/490HA	200	4	300	350	16	16	3275
300/490HA	250	4	300	350	16	16	3120
300/490HA	315	4	300	350	16	16	3325
300/490HA	355	4	300	350	16	16	3305
300/490HA	400	4	300	350	16	16	3405
300/570HA	250	4	300	350	16	16	3265
300/570HA	315	4	300	350	16	16	3470
300/570HA	355	4	300	350	16	16	3450
300/570HA	400	4	300	350	16	16	3550
300/570HA	450	4	300	350	16	16	3995
300/570HA	500	4	300	350	16	16	4105
300/570HA	560	4	300	350	16	16	4370

Pumps with axially split housing

Single pumps (heating, air-conditioning, cooling and industry)

Dimensions, weights Wilo-SCP

Dimensions, weights							
Wilo-SCP ...	Nominal motor power	Number of poles	Nominal diameter		Flanges		Weight approx.
	P ₂	–	DN ₂	DN ₁	PN ₁	PN ₂	M
	[kW]	–	[mm]		–		[kg]
300/570HA	630	4	300	350	16	16	5393
300/590HA	250	4	300	350	16	16	4168
300/590HA	315	4	300	350	16	16	4373
300/590HA	355	4	300	350	16	16	4275
300/590HA	400	4	300	350	16	16	4375
300/590HA	450	4	300	350	16	16	4863
300/590HA	500	4	300	350	16	16	4973
300/590HA	560	4	300	350	16	16	5238
300/590HA	630	4	300	350	16	16	6138
300/660DV	250	4	300	350	25	25	3718
300/660DV	315	4	300	350	25	25	3914
300/660DV	355	4	300	350	25	25	3903
300/660DV	400	4	300	350	25	25	4003
300/660DV	450	4	300	350	25	25	4403
300/660DV	500	4	300	350	25	25	4513
300/660DV	560	4	300	350	25	25	4778
300/660DV	630	4	300	350	25	25	5678
350/470HA	200	4	350	450	16	16	3325
350/470HA	250	4	350	450	16	16	3160
350/470HA	315	4	350	450	16	16	3365
350/470HA	355	4	350	450	16	16	3390
350/470HA	400	4	350	450	16	16	3490
350/500HA	110	6	350	450	16	16	2500
350/500HA	132	6	350	450	16	16	2500
350/500HA	160	6	350	450	16	16	3042
350/500HA	200	6	350	450	16	16	3282
350/640HA	200	6	350	400	16	16	4290
350/640HA	250	6	350	400	16	16	4420
350/640HA	315	6	350	400	16	16	4530
350/640HA	355	6	350	400	16	16	5248
350/640HA	400	6	350	400	16	16	5498
350/640HA	450	6	350	400	16	16	5898
400/480HA	110	6	400	500	16	16	2677
400/480HA	132	6	400	500	16	16	2687
400/480HA	160	6	400	500	16	16	3009
400/480HA	200	6	400	500	16	16	3249
400/540HA	90	6	400	500	16	16	2588
400/540HA	110	6	400	500	16	16	2775
400/540HA	132	6	400	500	16	16	2775
400/540HA	160	6	400	500	16	16	3290
400/540HA	200	6	400	500	16	16	3530
400/540HA	250	6	400	500	16	16	3660
400/540HA	315	6	400	500	16	16	3770

Pumps with axially split housing

Single pumps (heating, air-conditioning, cooling and industry)



Dimensions, weights Wilo-SCP

Dimensions, weights							
Wilo-SCP ...	Nominal motor power	Number of poles	Nominal diameter		Flanges		Weight approx.
	P ₂		DN ₂	DN ₁	PN ₁	PN ₂	M
	[kW]	–	[mm]		–		[kg]
400/550HA	160	6	400	500	16	16	3466
400/550HA	200	6	400	500	16	16	3706
400/550HA	250	6	400	500	16	16	3836
400/550HA	315	6	400	500	16	16	3946
400/660DV	315	4	400	500	16	16	4985
400/660DV	355	4	400	500	16	16	5063
400/660DV	400	4	400	500	16	16	5163
400/660DV	450	4	400	500	16	16	5563
400/660DV	500	4	400	500	16	16	5673
400/660DV	560	4	400	500	16	16	5938
400/660DV	630	4	400	500	16	16	6838
400/690HA	250	6	400	450	16	16	3816
400/690HA	315	6	400	450	16	16	3926
400/690HA	355	6	400	450	16	16	4670
400/690HA	400	6	400	450	16	16	4920
400/690HA	450	6	400	450	16	16	5320
400/690HA	500	6	400	450	16	16	5780
400/690HA	560	6	400	450	16	16	5945
400/690HA	630	6	400	450	16	16	6345
400/710HA	200	6	400	450	16	16	4640
400/710HA	250	6	400	450	16	16	4770
400/710HA	315	6	400	450	16	16	4880
400/710HA	355	6	400	450	16	16	5624
400/710HA	400	6	400	450	16	16	5874
400/710HA	450	6	400	450	16	16	6274
400/710HA	500	6	400	450	16	16	6734
400/710HA	560	6	400	450	16	16	6899
400/710HA	630	6	400	450	16	16	7299

Pumps with axially split housing

Switchgears and control devices

Plug-in modules, switchgears, motor protection, accessories

Series overview

Control device: Vario control system Wilo-VR-HVAC



> Control device for glandless and glanded pumps

(electronically regulated stageless pumps and/or pumps with integrated frequency converter)

- Variable-control system for stageless performance control of pumps of the TOP-E/-ED, Stratos/-D/-Z/-ZD, IP-E/DP-E, IL-E/DL-E, IL-E...BF series
- For the control modes $\Delta p-c$ and $\Delta p-v$ in heating and air-conditioning technology
- Pump performance splitting with up to 4 units
- Nominal power up to $P_2 = 22$ kW
- Speed range between 100 % and 40 %
- Includes full motor protection device

Control device: Comfort control system Wilo-CRn



> Control device for glandless and glanded pumps

(electronically regulated stageless pumps and/or pumps with integrated frequency converter)

- Comfort-control system for stageless power control of pumps of the series Stratos/-D/-Z/-ZD, IP-E/DP-E, IL-E/DL-E, IL-E...BF
- For all control modes in heating and air-conditioning technology
- Pump performance splitting with up to 6 units
- Nominal power up to $P_2 = 22$ kW
- Speed range between 100 % and 40 %

Control device: Wilo-CC-HVAC System



> Switchgear for glandless and glanded pumps

(Standard pumps with fixed speed)

- Comfort control system for continuous performance control of conventional circulation pumps with three-phase motor
- For all control modes in heating and air-conditioning technology
- Pump duty splitting with up to 6 units (more units on request)
- Nominal power up to $P_2 = 200$ kW (higher power on request)
- Speed range between 100 % and 40 %
- Incl. motor protection device

Control device: Comfort control system Wilo-CR



> Control device for glandless and glanded pumps

(Standard pumps with fixed speeds)

- Comfort control system for stageless performance control of commercially available circulation pumps with a three-phase AC motor
- Suitable for all control modes used in heating, air-conditioning and pressure boosting
- Pump performance splitting with up to 6 units
- Nominal power to $P_2 = 30$ kW (to $P_2 = 200$ kW on request)
- Speed range between 100 % and 40 %
- Includes full motor protection device

Pump performance control

Pump performance control

Load-specific excess pump performance

Circulation pumps for central heating and air-conditioning as well as the hydraulic pipe system must be designed to be capable to meet the maximum climatic requirements.

These maximum load conditions, however, only exist on a few days during the heating/cooling season. A typical load curve for a central heating system is shown on the diagram. Centralised and decentralised control systems intervene continuously in the system's hydraulics in order to make adjustments to the actual load situation; in most cases, they cause a reduction of the volume flow while at the same time increasing the pump delivery head. Such operating states are not economical for pump operations, since lower delivery heads would in fact be sufficient, particularly for a low volume flow; in addition, the noise levels that would result must be avoided under all circumstances.

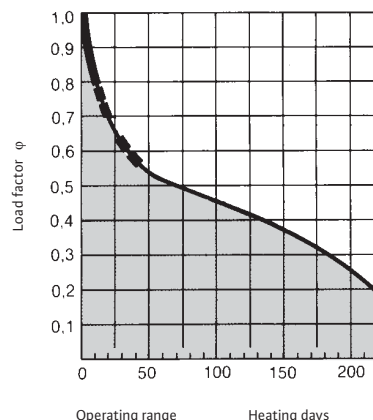

Fig.: Typical load factor of a central heating system during a heating period of roughly 5500 hours

The Wilo solution: load-sensitive power adjustment

Control mode	Pump type/ pump model	Signal/ control variable	Control system
Integrated infinitely variable differential-pressure control	Stratos/Stratos-Z Star-E Star-ZE TOP-E IP-E/IL-E	Δp	Standard equipment
Time-dependent activation/deactivation – single pumps	TOP-Z	t	SK 601
	Star-Z	t	S1R-h/SK 601
	RS	t	SK 601
Double pump control	Stratos/Stratos-Z/ Stratos-D/Stratos-ZD	$\Delta p, t$	Stratos IF-Module
	TOP-E/-ED	$\Delta p, t$	IF-Module
	IP-E/DP-E	$\Delta p, t$	–
	IL-E/DL-E	$\Delta p, t$	IF-Module
	Glandless and glanded pumps	$\Delta p, +T, \Delta T, t$	3
Infinitely variable performance control – single- and multi-pump systems	Glandless and glanded pumps	$\Delta p, \pm T, \Delta T, t, DDC$	CR system, CC system, VR system
Motor protection	Glandless pumps	–	SK 602/SK 622
Building automation	–	–	Wilo-Control

Δp = differential pressure
 $\pm T$ = feed/return temperature
 ΔT = differential temperature
 t = time

Switchgears and control devices

Planning guide

Pump performance control

Need for control

Due to the constant further development of equipment for building services and the growing sensitivity towards energy consumption, three main factors were decisive for the use of controls for heating pumps in the past.

1. Optimisation of functions

Adjustment of the flow rate/heat volume flow to requirements, particularly to stabilise hydraulic conditions and to reduce circulation losses.

2. Economic efficiency

Reduction of the electricity consumption and operating costs, particularly during partial or low-load operation (i.e. for more than 80% of the operating time).

3. Comfort

Avoiding system noise, in particular flow noise and noise in the thermostatic valves.

In the context of reducing CO₂ emissions and environmental issues, saving electricity plays an ever more important role. It is widely known that generating power from fossil fuels produces significant levels of CO₂ emissions. In Germany, engineers use the calculation principle that one kWh of electricity generated in a power station produces about 0.56 kg of CO₂ in the form of emissions. The decisive factor for concentrating studies on pumps in particular is their proportionally high share of power consumption in the context of the energy balance of buildings. The causes for this are the high levels of operating hours as well as the familiar phenomenon of over-dimensioning heating pumps during the planning stage, factors which considerably add to the energy balance. Over-dimensioning by a factor of 2 to 5 times is quite frequent.

ters volume flow, pressure difference and output directly relate to changes of speed.

$$n_1/n_2 = Q_1/Q_2 \quad (n_1/n_2)^2 = H_1/H_2 \quad (n_1/n_2)^3 = P_1/P_2$$

For example, when the speed is doubled, the volume flow is increased by a factor of two and the delivery head by a factor of 4 while the input power must be about 7 to 8 times greater.

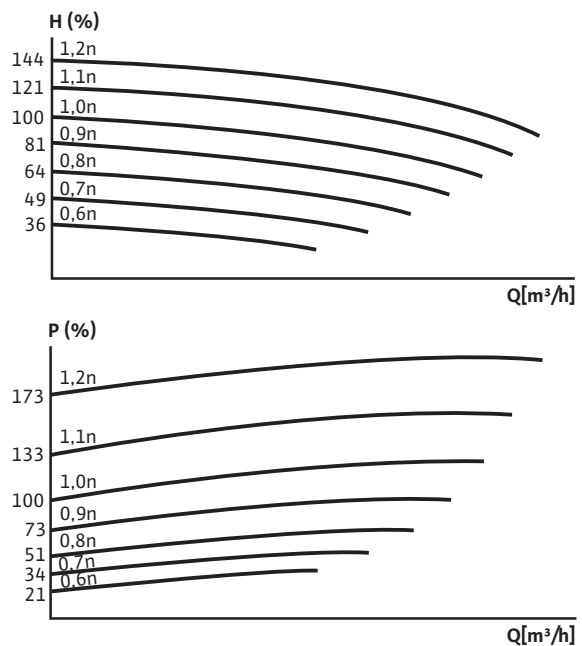

Fig.: Pump curves of a pump during operation at different speeds

Single-family house	Large building
Pumps account for 10 –15% of the overall power consumption, because...	Pumps account for 5 – 8% of the overall power consumption
<ul style="list-style-type: none"> - There are two to four pumps (heating/secondary hot water circulation/accumulator charging, etc.), each pump with about 1500 h to 5000 h operating time per year (depending on the application), i.e. with three pumps on average: - 3 x 65 W x approx. 3500 a/h = approx. 700 kWh/a - By comparison: average, statistical total power consumption for a single-family house = approx. 5000 to 8000 kWh 	

Pump performance control by speed variation

Of the many methods developed and tried in the past to automatically adjust the heating pump output to actual load demands, among them mechanical/hydraulic processes (bypass/throttling circuits etc.), the method of speed control has established itself on a lasting basis. Particularly high efficiency and easy handling have ensured the dominance of speed control, since ideally, the performance parame-

Switchgears and control devices

Wilo-Vario and Comfort control systems VR, CRn, CR, CC



Performance features

	Wilo control device...			
	VR-HVAC	CRn	CC-HVAC	CR
Applications				
Pump versions	Glandless/glanded pumps	Glandless/glanded pumps	Glandless/glanded pumps	Glandless/glanded pumps
Pump types	Electronically controlled pumps	Standard/electronically controlled pumps	Standard pumps	Standard pumps
Number of pumps	1–4	1–6	1–6 ¹⁾	1–6
Technical data				
Complete device	•	Power supply for pumps required onsite	•	•
Modular design	•	•	•	•
Nominal power range P ₂	0.37–22.0 kW	1.1–200 kW	1.1–200 kW ²⁾	1.1–200 kW
Activation types:	Infinitely variable, analogue	Infinitely variable, analogue/star-delta opt.	direct/star-delta	direct/star-delta
Electrical connection standard model	3~400 V, 50 Hz or 1~230 V, 50 Hz	1~230V, 50 Hz Power connection of the pumps onsite	3~400 V, 50 Hz	3~400 V, 50 Hz
Protection class	IP 54	IP 00 + IP 42 standard / IP 54 optional	IP 54	IP 00 + IP 42 standard / IP 54 optional
Permitted ambient temperature:	0 °C to +40 °C	0 °C to +40 °C	0 °C to +40 °C	0 °C to +40 °C
Speed range	Infinitely variable, analogue, 2–10 V, 3–10 V, 4–10 V pre-selectable, Min. pump speed acc. to name plate up to 100 %	Between 40% and 100% of the nominal motor speed	Between 40% and 100% of the nominal motor speed	Between 40% and 100% of the nominal motor speed
Control modes (description on the following pages)				
Δp-c	•	•	•	•
Δp-c (TA)	–	•	o	•
Δp-q (m ² /h)	–	•	o	•
Δp-v	•	•	•	•
T _A (outside temperature), controller	–	•	o	•
T-abs (process temp.), controller	–	•	o	•
T _F (feed temperature), controller	–	•	o	•
T _R (return temperature), controller	–	•	o	•
ΔT-c	–	•	o	•
ΔT-v	–	•	o	•
Manual control mode (DDC)	–	•	•	•
Q-c	–	•	o	•

• = available, – = not available, o = optional on request

1) Larger number of pumps on request

2) Higher nominal motor power values on request

Switchgears and control devices

Wilö-Vario and Comfort control systems VR, CRn, CR, CC

Performance features				
	Wilö control device...			
	VR-HVAC	CRn	CC-HVAC	CR
Control and signalling functions				
Remote speed adjustment (control input)	–	0/4 – 20 mA 0/2 – 10 V	0/4 – 20 mA (standard) 0/2 – 10 V (opt. on request)	0/4 – 20 mA 0/2 – 10 V
Remote setpoint adjustment	–	0/4 – 20 mA 0/2 – 10 V	0/4 – 20 mA (standard) 0/2 – 10 V (opt. on request)	0/4 – 20 mA 0/2 – 10 V
Run and fault signal visualisation	•	•	•	•
Control input "Setpoint switchover"	–	•	•	•
"Overriding Off" control input	•	•	•	•
SBM	•	•	•	•
SSM	•	•	•	•
Fault-actuated switchover from frequency converter to mains operation	–	–	•	•
Fault-actuated switchover from duty pump to standby pump	•	•	•	•
Status display for pumps and frequency converters	–	•	•	•
Equipment features				
Motor protection	Integrated in pump	WSK / SSM, integrated in pump	WSK / TS (PTC)/ TSA	ETA / TS (PTC) / WSK
Graphic display	Menu navigation/ symbol display	Menu navigation/plain text display	Menu navigation/ plain text display/ symbol display	Menu navigation/ plain text display
User-oriented menu navigation with multilingual plain text display	–	•	•	•
Manual control panel	Manual /0 /Auto	Manual /0 /Auto	Manual /0 /Auto	Manual /0 /Auto
Fault memory	9 messages	35 messages	35 messages	35 messages
Fault-actuated switchover	•	•	•	•
Pump kick	•	•	•	•
Run-time optimisation/ pump cycling	Only time-dependent pump cycling	•	•	•
Pump duty splitting	up to 4 pumps	up to 6 pumps	up to 6 pumps ¹⁾	up to 6 pumps
PID controller	•	•	•	•
Integrated real time clock with summer/winter time change	–	•	•	•
Integrated individual/total operating hours counter	•	•	•	•
Service life optimisation for multi-pump systems	–	•	•	•
Conductivity testing of the actual value section	•	•	•	•

• = available, – = not available, o = optional on request

1) Larger number of pumps on request

2) Higher nominal motor power values on request

Switchgears and control devices

Wilò-Vario and Comfort control systems VR, CRn, CR, CC



Performance features

	Wilò control device...			
	VR-HVAC	CRn	CC-HVAC	CR
"Mains - Emergency - Operation" service selector switch for maintenance purposes	–	•	•	•
Night reduction to minimum speed and/or second controlled level via internal clock timer	–	•	•	•
Remote acknowledgement of collective fault signal	–	• (with DDC board)	◦	• (with DDC board)
Pilot pump function	–	•	•	•
Clock timer	–	•	•	•
Switchover to second setpoint level	–	• (with DDC board)	• (max. 3)	• (with DDC board)
Individual run and fault signals for pumps and converters	• (with options board)	• (with signal board)	◦	• (with signal board)
Manual / automatic switchover with external switch	–	• (with control board)	◦	• (with control board)
Connection option for a repair switch (potential-free contact)	–	• (with control board)	◦	• (with control board)
Accessories				
Differential-pressure sensor, DDG	•	•	•	•
Temperature boards, KTY / PT 100	–	•	–	•
Temperature module, PT 100	–	–	◦	–
Temperature sensor, TSG	–	•	–	•
Outdoor temperature sensor, KTY	–	•	–	•
Outdoor temperature sensor, PT 100	–	• (to be provided by the customer)	◦	• (to be provided by the customer)
PTC thermistor triggering relay	–	• (to be taken into account during the selection of the pump)	◦ (to be taken into account during the selection of the pump)	• (to be taken into account during the selection of the pump)
Control board	–	•	–	•
Signal board	• (with options board)	•	–	•
DDC board	–	•	–	•
Volume-flow transmitter	– (to be provided by the customer)	• (to be provided by the customer)	– (to be provided by the customer)	• (to be provided by the customer)

• = available, – = not available, ◦ = optional on request

1) Larger number of pumps on request

2) Higher nominal motor power values on request

Switchgears and control devices

Wilo-Vario and Comfort control systems VR, CRn, CR, CC

Performance features				
	Wilo control device...			
	VR-HVAC	CRn	CC-HVAC	CR
Special features				
DPM (dual pump management)	not required for DPM with: Stratos/-D /-Z/-ZD, TOP-E /-ED, VeroLine IP-E, VeroTwin DP-E, CronoLine IL-E, CronoTwin DL-E	not required for DPM with: Stratos/-D /-Z/-ZD, TOP-E /-ED, VeroLine IP-E, VeroTwin DP-E, CronoLine IL-E, CronoTwin DL-E	not required for DPM with the following series: Stratos/-D /-Z/-ZD, TOP-E /-ED, VeroLine IP-E, VeroTwin DP-E, CronoLine IL-E, CronoTwin DL-E	not required for DPM with: Stratos/-D /-Z/-ZD, TOP-E /-ED, VeroLine IP-E, VeroTwin DP-E, CronoLine IL-E, CronoTwin DL-E

• = available, – = not available, o = optional on request

1) Larger number of pumps on request

2) Higher nominal motor power values on request

Control modes

Differential pressure – constant ($\Delta p - c$)

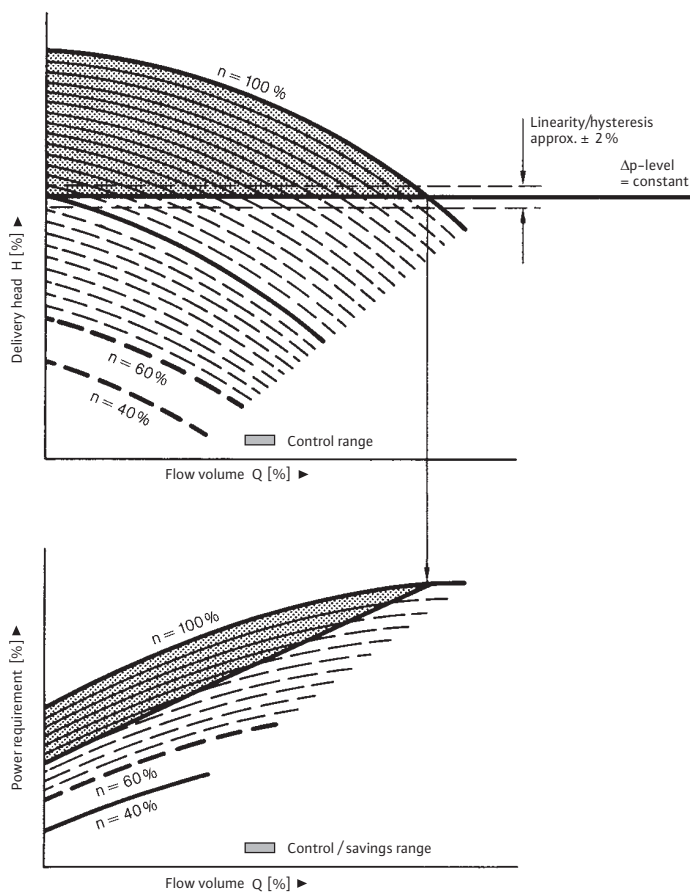

Fig.: Pump curve behaviour for infinitely variable constant differential pressure control ($\Delta p - c$)

The differential pressure setpoint to be adjusted at the control devices is kept constant across the entire volume flow range. That means that any reduction of the volume flow (Q) caused by the throttling of the hydraulic control units will in turn adjust the pump output to actual system requirements by reducing the speed of the pump. Along with the change in speed, the power consumption is reduced to below 50% of the nominal power. The application of the differential pressure control requires a variable volume flow in the system. Peak-load operation, e.g. in conjunction with a double pump, is performed automatically and according to the load by the control system. If the controlled base-load pump is no longer able to supply the required load, the second pump is automatically cut in. The variable speed pump is then run down until the preset differential pressure setpoint value is reached.

Required accessories:
 Differential pressure sensor, DDG
 (see also "Performance features" table)

Switchgears and control devices

Wilo-Vario and Comfort control systems VR, CRn, CR, CC

Control modes

Differential pressure – variable ($\Delta p - v$)

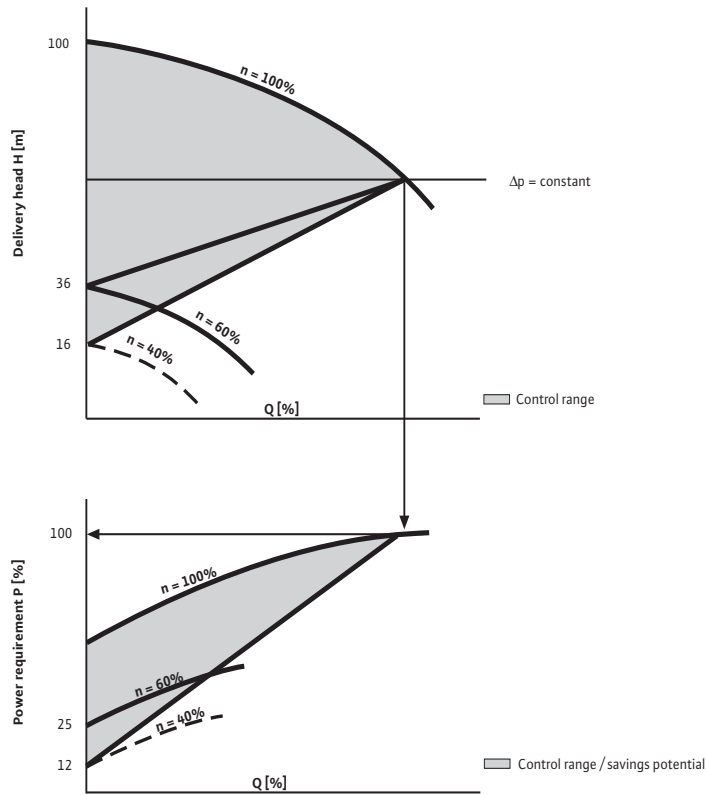

Fig.: Pump curve behaviour with infinitely variable differential pressure control ($\Delta p - v$)

When upgrading existing systems it is not always possible to evaluate the index circuit which. Original installations have been completed years ago and now, after installing thermostatic valves, noise problems have developed. The index circuit of the system is not known or it is not possible to integrate the new sensor lines that are required. An extension of the control range is nevertheless possible using the $\Delta p - v$ control mode (recommended for single-pump systems). A processor unit of the control system adapts the differential pressure setpoint value to a preset variable differential-pressure curve by means of a comparison of the setpoint /actual value. In parallel operation, the differential pressure is kept constant at the design level after the first peak-load pump has been cut in.

Required accessories:
Differential pressure sensor, DDG
(also see "Performance features" table)

Control modes

Differential pressure – delivery-superimposed ($\Delta p - q$)

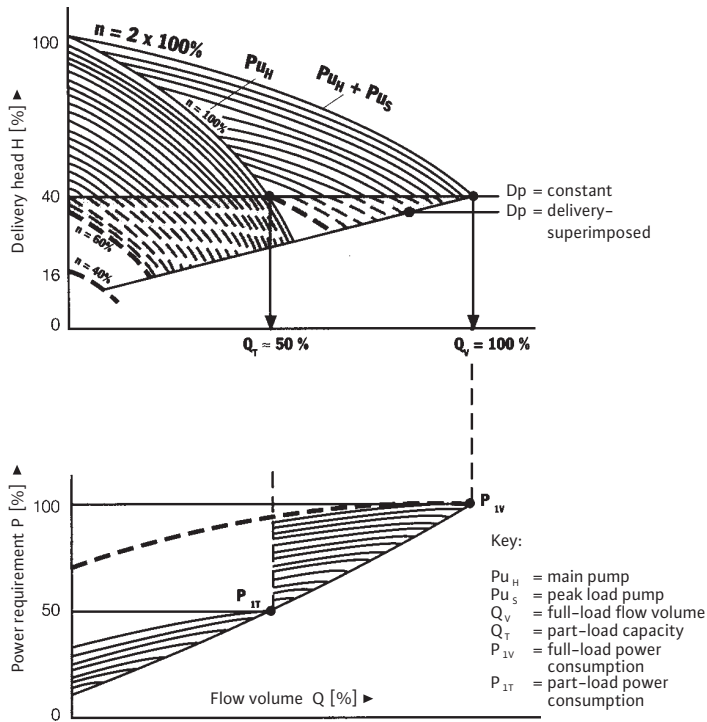

Fig.: Pump curve behaviour of a multi-pump system with infinitely variable delivery-superimposed differential pressure control ($\Delta p - q$)

In order to avoid the time and expenses associated with index circuit evaluation (extensive and expensive cable routing, amplifiers, etc.), it is possible to override the differential pressure setpoint value directly with a signal proportional to delivery. Using this method, it is possible, even with multi-pump systems, to achieve a control-range extension in spite of central measured-value acquisition (differential pressure sensor at the pump).

This method requires, in addition to the differential pressure sensor which is to be fitted directly on the pump system, the heating-circuit output or the input of the consumer rail, the provision by the customer of a volume-flow transmitter (0/4–20 mA) to be installed in the system's main feed pipe.

The use of the $\Delta p - q$ control is recommended for such systems whose index circuit or system performance are not known or in such cases where long signal distances cannot be bridged, particularly for such systems where volume-flow transmitters are already available.

Required accessories:

Differential pressure sensor, DDG
 Volume-flow transmitter (provided by the customer)
 (also see "Performance features" table)

Switchgears and control devices

Wilo-Vario and Comfort control systems VR, CRn, CR, CC

Control modes

Differential pressure – temperature superimposed ($\Delta p - T$)

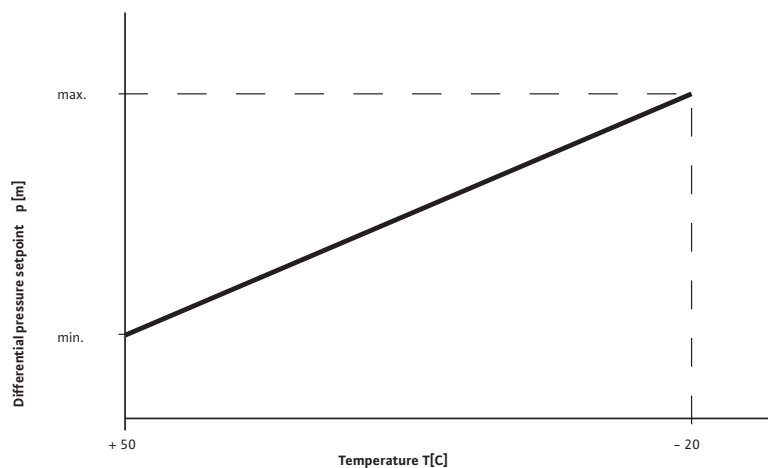

Fig.: Differential pressure setpoint variation according to a temperature

The operational performance of the hydraulic system can be further optimised by adapting the differential pressure setpoint value for pump output control according to a superimposed reference variable (e.g. outdoor temperature). The differential pressure setpoint value and thus the pump output is reduced with rising outdoor temperatures, it is increased with falling outdoor temperatures.

Required accessories:

Differential-pressure sensor, DDG

Temperature board, KTY 10

or

Temperature board, PT 100

CC temperature module, PT 100

(also see "Performance features" table)

Process temperature sensor or outdoor temperature sensor, PT 100 or KTY

Control modes

Differential temperature control (ΔT)

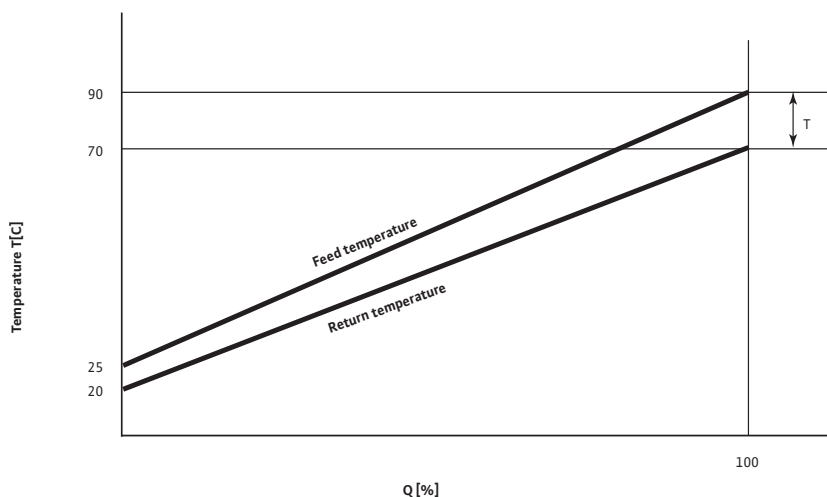

Fig.: Volume flow variation according to the temperature spread

Heating/air-conditioning systems vary in terms of their cooling/heating requirements according to outdoor temperature fluctuations. A number of installations are installed without actuating units or the option of controlling the volume flow (single-pipe heating systems, primary circuits, etc.). Moreover, pure throttling or bypass controls are highly uneconomical. The secondary power consumption (electricity) for the pump drive is also unnecessarily high during the transition period.

The differential-temperature control ΔT is one option for maintaining a constant difference between feed and return temperatures as a result of weather- and usage-dependent temperature spread. The heat flow becomes variable due to the changes in flow rates and the transferred heating/cooling capacity can be controlled independently of feed or return temperatures. Differential-temperature controls should therefore only be used with individual consumers or with systems with a known control time constant to be able to use them in a straightforward manner.

Required accessories:

Temperature board, KTY 10

or

Temperature board, PT 100

CC temperature module, PT 100

(also see "Performance features" table)

Temperature sensor, TSG or PT 100 (provided by the customer)

Switchgears and control devices

Wilo-Vario and Comfort control systems VR, CRn, CR, CC

Control modes

Temperature control ($\pm T$)

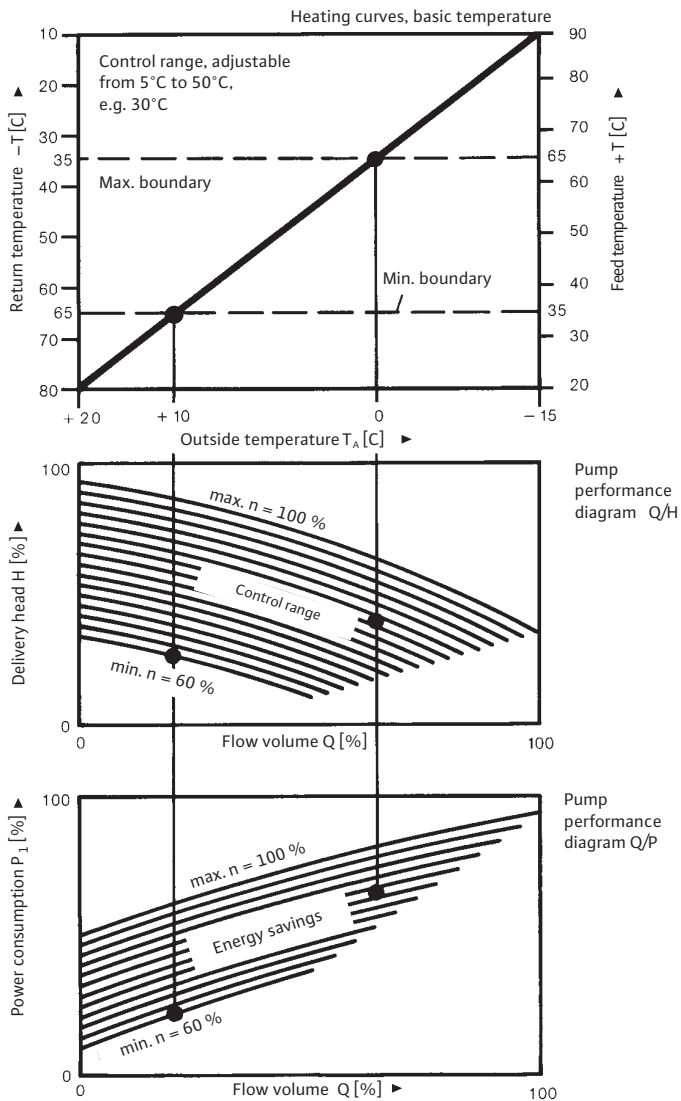

Fig.: System diagram of the infinitely variable temperature control

With the case of pump control according to the temperature, the control signal ($\pm T$) results in a variation of pump output, but there is no adjustment of the variation or its results by means of feedback of the comparison of the setpoint/actual value.

Fixed motor speeds have been assigned to the pump for specific feed/return temperatures according to an empirically predetermined pump curve.

A falling feed temperature (+T) or a rising return temperature (-T) will result in automatic speed reduction and thus the reduction of the pump performance input.

Temperature control $\pm T$ can only be applied to single pump operation. Feed or return temperature-sensitive peak-load operation is technically not feasible.

Required accessories

- Temperature board, KTY 10
- or
- Temperature board, PT 100
- CC temperature module, PT 100 (also see "Performance features" table)
- Temperature sensor, TSG or PT 100 (provided by the customer)

Control modes

Variable differential temperature ($\Delta T - v$)

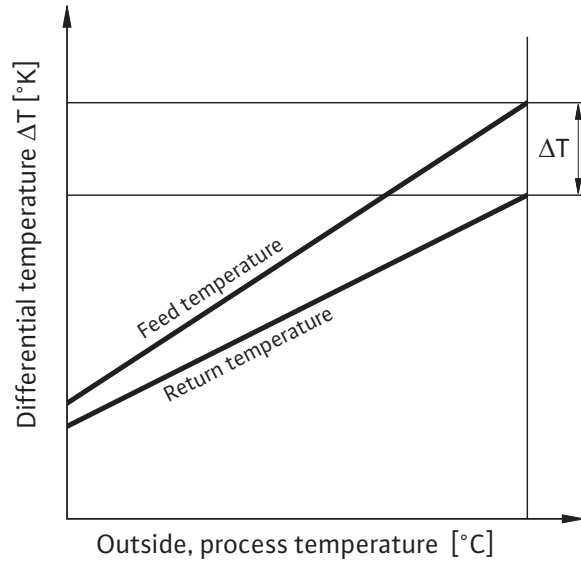

Fig.: Differential temperature according to the process or outdoor temperature

The $\Delta T-v$ control function is particularly suitable for pump output control in single-pipe heating systems, district heatings, systems with condensing boiler technology and cooling systems.

The $\Delta T-v$ control mode ensures that the differential temperature is spread variably according to another temperature, e.g. the outdoor temperature. This means that only the water quantity required for heat transfer is circulated. This leads to significant energy savings on the drive side. Furthermore, the return temperature can also be drastically reduced. The large temperature spread improves the efficiency of boilers or heat exchangers, and limits the return temperature, as required e.g. in most district heating networks.

Required accessories:

- Temperature board, KTY 10
- or
- Temperature board, PT 100
- CC temperature module, PT 100 (also see "Performance features" table)
- Temperature sensor, TSG or PT 100 (provided by the customer)
- Process temperature sensor or outdoor temperature sensor, PT 100 or KTY

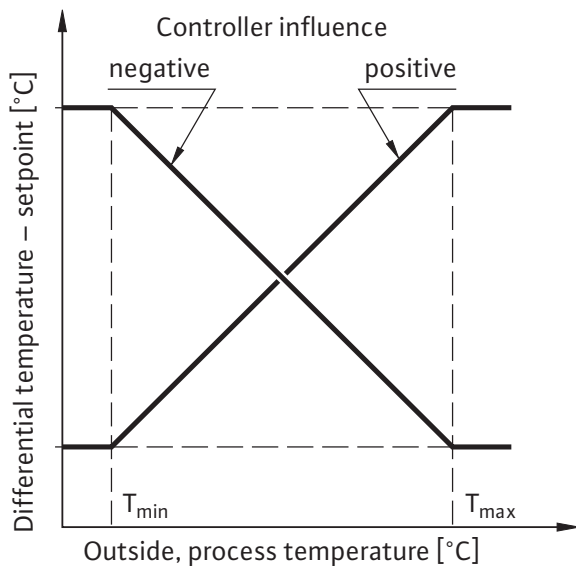

Fig.: Effect on the differential temperature

Switchgears and control devices

Wilo-Vario and Comfort control systems VR, CRn, CR, CC

Control modes

Constant volume flow control (Q - c)

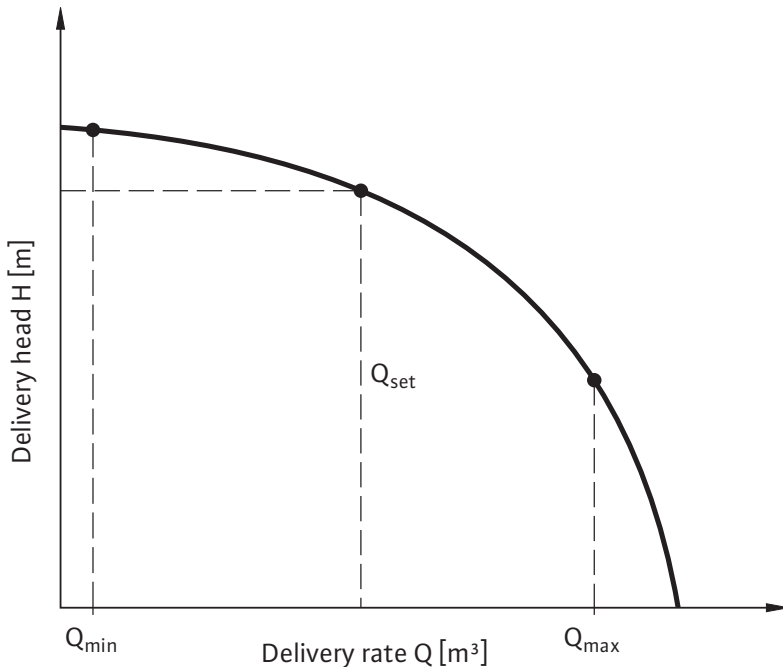

The volume flow which is set at the CR device is kept constant. If the volume flow Q decreases, the speed of the pump system is increased until the set volume flow is reached again. If the volume flow increases, the speed is reduced so that only the required rate is pumped.

Fig.: Principle of the constant volume flow control

Pressure - constant (p - c)

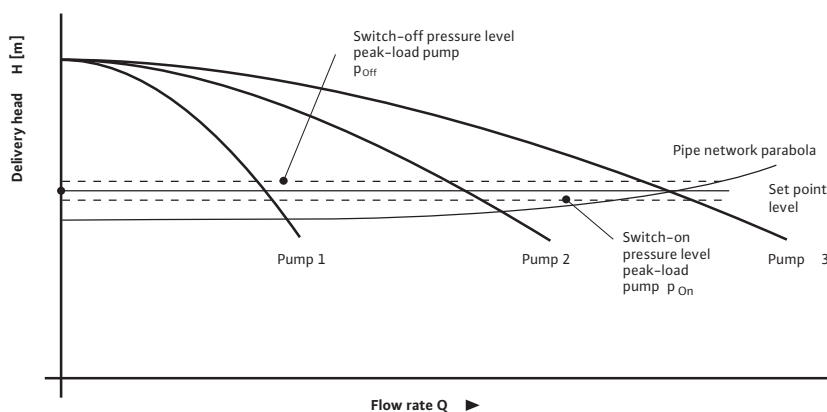

Fig.: Constant pressure control (p - c) using a 3-pump system as an example

The Q-c control function is applied practically in such cases where a constant, adjustable volume flow is to be pumped. Such cases are for example cooling systems, cooling towers, test stands or systems for water supply, water treatment and sewage disposal. Flow rates of 2 – 2000 m³/h can be controlled.

Examples of the application of flow rate controls:

- Mixing of chemically different well waters in an elevated tank for establishing a consistent water quality
- Delivery of cold and cooling water according to the connected cooling towers or consumers
- Mixing sewage (municipal and industrial applications) for achieving a defined untreated sewage composition, adapted to the sewage treatment in a sewage treatment plant
- Dosing of chemicals in chemical and environmental engineering
- Agricultural irrigation

Required accessories:

- Flow rate meter provided by the customer
- Monitoring of limit values is to be implemented onsite (system protection)

The constant pressure control mode (p - c) is suitable for use in conjunction with open pipe systems, e.g. water supply and pressure boosting applications.

The pump output is adapted according to water requirements (pressure-dependent) along a setpoint level. Multi-pump systems require the activation and deactivation of base-load and peak-load pumps according to requirements. Fluid hammers caused by premature deactivation and immediate reactivation are thus fully eliminated.

In a pressure boosting system, the base-load pump is deactivated via the control system at $Q = 0$ (also see "Performance features" table)

Series description Wilo-VR-HVAC system

VR-HVAC system

Digitally-controlled, infinitely variable Vario control system for electronically controlled glandless and glanded pumps of the Stratos, TOP-E, VeroLine-IP-E and CronoLine-IL-E series, for mounting single-pump and multiple-pump systems.



Typical field of application of the Wilo-VR-HVAC system is water circulation in heating, ventilation, cooling and air-conditioning systems of large buildings such as hospitals, hotels, schools, department stores, industrial systems, residential, commercial and public buildings. Latest pump technology and digital control electronics fulfil all requirements of the Wilo-VR-HVAC system for new installations and retrofitting:

- For all glandless and glanded pumps with integrated power electronics up to P2 = 22 kW nominal power.
- For pump duty splitting with up to 4 units (to make best use of the low-power split units in low-load operation).
- Prevention of flow or cavitation noise.
- Reduction of operating costs due to energy savings.

Operating principle

The control device is for controlling and regulating circulation pumps with electronic control or integrated pump output electronics. The differential pressure of a system is controlled according to the load with appropriate signal transmitters. The controller affects the frequency converter which has an effect on the pump speed. A modification of the speed changes the delivery head and thus the power output of the single pumps. According to load requirements, pumps are activated or deactivated. The control device can control up to 4 pumps.

Equipment features

- PID controller
- Lockable main switch
- Graphical LC display for the indication of all values and operating states
- Red-button technology (one-button operation)
- LEDs for indicating operation standby, pump(s) in operation, faulty pump(s)
- Circuit breakers and output terminals for the power supply of pump(s)
- Integrated signal board (option)
- Automatic pump cycling

- Emergency operation as an option
- Selection of a standby pump

Infinitely variable speed control

An electronic Wilo DDG differential pressure sensor delivers the actual differential pressure value as 4 – 20 mA current signal. Then the controller maintains the differential pressure at a constant level by means of the comparison of the setpoint/actual values. If there is no "External Off" signal and no fault, at least one pump is running. The pump speed depends on the load. If the required output cannot be covered by this pump (base-load pump), another pump is cut in, the speed of which is then controlled according to the reduction to the setpoint. Pumps, which are already running, keep operating at maximum speed (peak-load pumps). If the demand decreases to such an extent that the controlling pump runs at its lowest output range and is not needed to cover the demand, this pump is deactivated and the control function is assigned to another pump which has previously been running at maximum speed.

Control modes $\Delta p-c$ and $\Delta p-v$ can be preselected in the menu. Only the first pump is controlled in $\Delta p-v$ mode. If more pumps are cut in, these are adjusted according to the $\Delta p-c$ curve.

Control modes

The following control modes can be preselected on the Wilo-VR-HVAC system for electronic performance control:

- For variable-delivery systems (e.g. heating systems with thermostatic valves):
- Constant differential pressure control ($\Delta p-c$)
- Variable differential pressure control ($\Delta p-v$)

Control and signalling functions

The standard Wilo-VR-HVAC system has an extensive range of control inputs/outputs for integration into external monitoring units to be provided by the customer:

- Analogue output, Δp_{out} (0 – 10 VDC), for indicating the actual value of the differential pressure sensor
- Activation/deactivation via external potential-free contact
- SSM collective fault signal as potential-free changeover contact
- SBM collective run signal as potential-free changeover contact
- IFS individual fault signal for each pump as potential-free changeover contact (optional)
- IRS individual run signal as potential-free changeover contact (optional)

Switchgears and control devices

Switchgears

Series overview Wilo-VR-HVAC system

Dimensions, weights Wilo-VR-HVAC system

Switchbox	Dimensions	Weight approx.
	Width x height x depth	M
	[mm]	[kg]
VR-HVAC 1x0.37WM	400 x 300 x 120	8.5
VR-HVAC 2x0.37WM	400 x 300 x 120	9.0
VR-HVAC 3x0.37WM	400 x 300 x 120	9.5
VR-HVAC 4x0.37WM	400 x 300 x 120	10.0
VR-HVAC 1x0.55WM	400 x 300 x 120	8.5
VR-HVAC 2x0.55WM	400 x 300 x 120	9.0
VR-HVAC 3x0.55WM	400 x 300 x 120	9.5
VR-HVAC 4x0.55WM	400 x 300 x 120	10.0
VR-HVAC 1x0.75WM	400 x 300 x 120	8.5
VR-HVAC 2x0.75WM	400 x 300 x 120	9.0
VR-HVAC 3x0.75WM	400 x 300 x 120	9.5
VR-HVAC 4x0.75WM	400 x 300 x 120	10.0
VR-HVAC 1x1.1WM	400 x 300 x 120	8.5
VR-HVAC 2x1.1WM	400 x 300 x 120	9.0
VR-HVAC 3x1.1WM	400 x 300 x 120	9.5
VR-HVAC 4x1.1WM	400 x 300 x 120	10.0
VR-HVAC 1x1.5WM	400 x 300 x 120	8.5
VR-HVAC 2x1.5WM	400 x 300 x 120	9.0
VR-HVAC 3x1.5WM	400 x 300 x 120	9.5
VR-HVAC 4x1.5WM	400 x 300 x 120	10.0
VR-HVAC 1x2.2WM	400 x 300 x 120	8.5
VR-HVAC 2x2.2WM	400 x 300 x 120	9.0
VR-HVAC 3x3.3WM	400 x 300 x 120	9.5
VR-HVAC 4x2.2WM	400 x 300 x 120	10.0
VR-HVAC 1x3.0WM	400 x 300 x 120	8.5
VR-HVAC 2x3.0WM	400 x 300 x 120	9.0
VR-HVAC 3x3.3WM	400 x 300 x 120	9.5
VR-HVAC 4x3.0WM	400 x 300 x 120	10.0
VR-HVAC 1x4.0WM	400 x 300 x 120	8.5
VR-HVAC 2x4.0WM	400 x 300 x 120	9.0
VR-HVAC 3x4.0WM	400 x 300 x 120	9.5
VR-HVAC 4x4.0WM	400 x 300 x 120	10.0
VR-HVAC 1x5.5WM	400 x 300 x 120	8.5
VR-HVAC 2x5.5WM	400 x 300 x 120	9.0
VR-HVAC 3x5.5WM	400 x 300 x 120	9.5
VR-HVAC 4x5.5WM	400 x 300 x 120	10.0
VR-HVAC 1x7.5WM	400 x 300 x 120	8.5
VR-HVAC 2x7.5WM	400 x 300 x 120	9.0
VR-HVAC 3x7.5WM	400 x 400 x 120	11.5
VR-HVAC 4x7.5WM	400 x 400 x 120	12.0
VR-HVAC 1x11WM	400 x 400 x 120	10.5

Series overview Wilo-VR-HVAC system

Dimensions, weights Wilo-VR-HVAC system

Switchbox	Dimensions	Weight approx.
	Width x height x depth	M
	[mm]	[kg]
VR-HVAC 2x11WM	400 x 400 x 120	11.0
VR-HVAC 3x11WM	600 x 600 x 250	34.5
VR-HVAC 4x11WM	600 x 600 x 250	35.0
VR-HVAC 1x15WM	400 x 400 x 120	10.5
VR-HVAC 2x15WM	400 x 400 x 120	11.0
VR-HVAC 3x15WM	600 x 600 x 250	35.0
VR-HVAC 4x15WM	600 x 600 x 250	35.5
VR-HVAC 1x18.5WM	400 x 300 x 120	10.5
VR-HVAC 2x18.5WM	400 x 300 x 120	11.0
VR-HVAC 3x18.5WM	600 x 600 x 250	35.0
VR-HVAC 4x18.5WM	600 x 600 x 250	35.5
VR-HVAC 1x22WM	400 x 300 x 120	10.5
VR-HVAC 2x22WM	400 x 300 x 120	11.0
VR-HVAC 3x22WM	600 x 600 x 250	35.5
VR-HVAC 4x22WM	600 x 600 x 250	36.0

Switchgears and control devices

Switchgears

Terminal diagrams Wilo-VR-HVAC system

Terminal diagram VR-HVAC 3~400 V

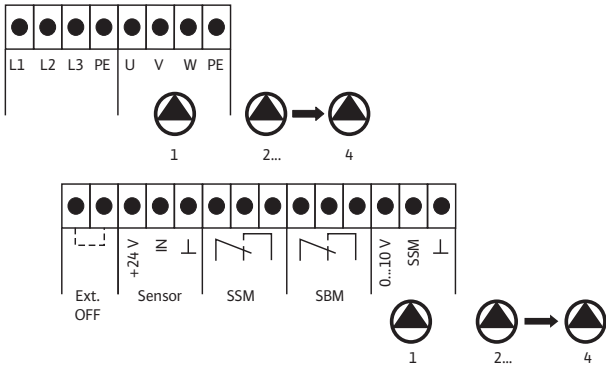

Terminal diagram VR-HVAC 1~230 V

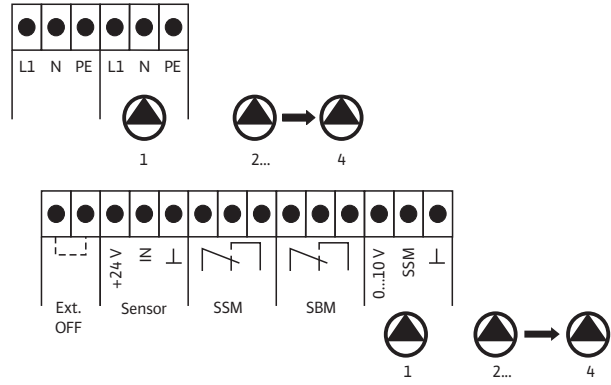

Series description Wilo-CR, Wilo-CRn, Wilo-CC

Wilo-Comfort control systems CR, CRn and CC

Digitally controlled, infinitely variable Comfort control systems for glandless and glanded pumps of all makes, single-pump and multi-pump systems.

CR version for conventional pumps with fixed speed.

CRn version for infinitely variable, electronically controlled pumps or pumps with integrated frequency converter.

CC version for conventional pumps with fixed speed.

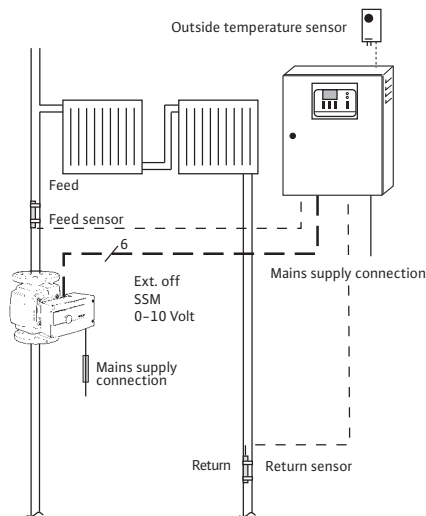
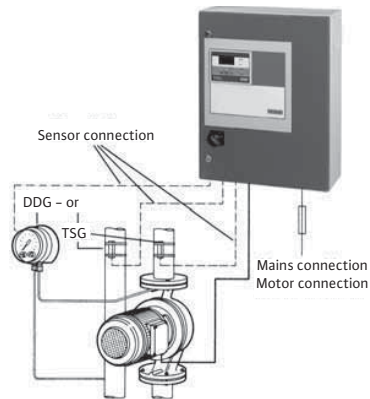

Typical fields of application of the Wilo-Comfort control devices CR, CRn and CRn are water circulation and water supply (e.g. pressure boosting)

- In residential, commercial and public buildings, hotels, hospitals, department stores and for industrial buildings. Most up-to-date digital control electronics fulfil all requirements of the Wilo-Comfort control systems for new installations and retrofitting:
- For CR version for all glandless and glanded pumps with three-phase motors with a nominal power up to $P_2 = 30$ kW (higher output values and other voltages on request)
- For CRn version independent of the power via analogue control signals 0/2 – 10 V or 0/4 – 20 mA
- For CC version for all glandless and glanded pumps with three-phase motors with a nominal power up to $P_2 = 200$ kW (higher output values and other voltages on request)
- For pump duty splitting with up to 6 units (to make best use of the low-power individual units in low-load operation)

- Prevention of flow or cavitation noise
- Lower operating costs due to energy savings
- Speed control range between 100% and 40% of the nominal power.

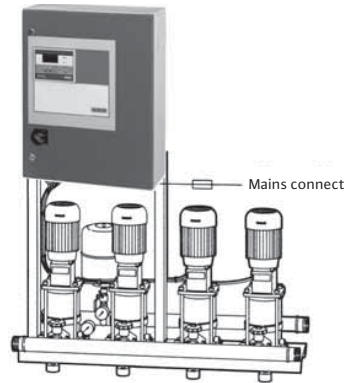

Operating principle

The Wilo-Comfort control systems allow the infinitely variable electronic adjustment of the pump output to meet the continuously varying operating conditions in the hydraulic system according to the control variables: pressure (p), volume flow (Q), temperature (T).

Equipment features

- PID controller
- Integrated real-time clock with summertime/wintertime change
- Integrated individual/total operating hours counter
- Service life optimisation for multi-pump systems
- Motor protection due to connection of WSK, PTC TS and TSA (for CR version)
- Motor protection due to connection of WSK and SSM (for CRn version)
- Motor protection due to connection of WSK, PTC TS and TSA (for CC version)
- Touch display with multi-colour backlight for CC version
- Alphanumerical LCD display for the CR and CRn versions (4-line) with backlight
- Status display for drives (e.g. pumps and frequency converters)
- User-oriented menu navigation with multi-language plain text display and/or symbol navigation
- Storage and display of extensive operating data
- Defined display of fault signals and storage in the history memory
- Conductivity test of the transmitter paths

Infinitely variable speed control

Infinitely variable speed control must be regarded as the ideal solution to the problem of achieving 100% harmonious adjustment of the pump output to the actual operating states of the system. Unfortunately, its particular inherent capability of reducing the speed right down to a very low level – about 10–20% of the residual speed – cannot be implemented in practice in heating applications. Speed reductions in the range below 60% residual speed and the resulting drop in delivery head (delivery head as a quadratic function of speed) may result in malfunctions and sometimes to a breakdown in water distribution. In this case, the Δp measuring point must be installed on what is called the index circuit of the system, i.e. the line or consumer with the greatest pressure losses. Extremely low speeds below 40%

Switchgears and control devices

Wilo-Comfort control systems CR, CRn, CC

Series description Wilo-CR, Wilo-CRn, Wilo-CC

of the nominal speed can also lead to thermal and mechanical overloading of the electric motors.

Control modes

The following control modes can be preselected for electronic pump output control with Wilo-Comfort control systems (also see "Performance features" table)

- For variable-delivery systems (e.g. heating systems with thermostatic valves):
 - Constant differential pressure control ($\Delta p-c$)
 - Variable differential pressure control ($\Delta p-v$)
 - Variable-delivery differential pressure control ($\Delta p-q$)
 - Temperature-superimposed differential pressure control ($\Delta p-T$)
 - Constant pressure control (p-c) for pressure boosting systems
 - Constant flow rate control (Q-c)
- For constant-volume systems (e.g. cooling systems with heat exchangers):
 - Differential temperature control (ΔT)
 - Process temperature control ($\pm T$)
 - Variable temperature control ($\Delta T-v$)

Control and signalling functions

The Wilo-Comfort control systems provide extensive control inputs and outputs as standard equipment for integration in external monitoring units provided by the customer (see also "Performance features" table)

- Remote setpoint adjustment (0 – 10 V/10 – 20 mA) preselectable (with CR and CRn)
- Remote setpoint adjustment (4 – 20 mA) preselectable (with CC)
- Activation/deactivation via external potential-free contact
- Activation of frost protection via external potential-free contact (only for heating/air-conditioning) via digital input
- Low water cut-out switch via external potential-free contact (only for pressure boosting) via digital input
- Collective fault signal/collective run signal as potential-free change-over contact
- "Mains – Emergency – Operation" service selector switch for maintenance personnel
- Switchover to second setpoint level (with CR and CRn)
- Switchover to second/third setpoint level (with CC)

The following optional control inputs and outputs are available:

- Remote acknowledgement of the collective fault signal
- Switchover to manual control mode
- Individual run and fault signals for pumps and converters
- Manual/automatic switchover
- Signalling contact connection of repair switches

Type key, CR control device (example: CR 1.1-2 WM)	
WM	Device version
	WM = wall-mounted installation IP 42 (IP 54 on request)
	FM = floor model IP 42 (IP 54 on request)
	SE = control-panel installation

Type key, CRn control system (example: CRn 1-2 TP WM)	
CRn	Comfort control technology, new
1-2	Number of pumps that can be connected: 1 – 2 3 – 4 5 – 6
TP, TK	Control mode: T = temperature P = PT 100 sensor K = KTY sensor
WM	Device version
	WM = wall-mounted installation IP 42 (IP 54 on request)
	SE = control-panel installation

Type key, CC control device (example: CC 2x1.1 FC WM)	
CC	Comfort Controller
2	Number of pumps to be controlled (1 – 6 pumps)
1.1	Maximum nominal motor power P_2 of pump to be controlled in kW
FC	Installation with frequency converter and sine filter
WM	Device version
	WM = wall-mounted installation, IP 54
	BM = floor model, IP 54

Type key, CR control device (example: CR 1.1-2 WM)	
CR	Comfort control technology
1.1	Maximum nominal motor power P_2 of pump to be controlled in kW
2	Number of pumps to be controlled (1 – 6 pumps)

Technical data Wilo-CR, Wilo-CRn, Wilo-CC

Wilo-Comfort control system CR

- Automatic, load-sensitive, infinitely variable speed control of glanded and glandless pumps with three-phase motor.
- For heating/air-conditioning according to the differential pressure Δp , feed/return temperature ($\pm T$) or differential temperature (ΔT) including free adjustment of the duty point by means of the advance

correction of the full-load pump output. For pressure boosting according to the pressure (p).

- Device version
 - Wall-mounted installation (WM) available only up to 4 kW
 - Floor models (FM) available above 5.5 kW
 - Control-panel installation (SE)

Connection data Wilo-CR

Device grading: Max. nominal motor power P_2 [kW] 3~400 V/50 Hz/60 Hz	1.1	2.2	3.0	4.0	5.5	7.5	11.0	15.0	22.0	30.0
Maximum output current I [A]	2.8	5.6	7.6	9.7	13.0	16.0	24.0	32.0	44.0	61.0
Power factor $\cos \phi$	> 0.90									
Efficiency: - for P_{max} - within the permitted partial load range	> 0.93 > 0.85									
Electrical connection	3~400 V/N/50 Hz/60 Hz									
Output voltage [V]	3 x 130 V – 400 V									
Output frequency [Hz]	(10 Hz) 12 Hz – 50 Hz/60 Hz									
Control range (% nominal motor speed)	40% – 100%									
Permitted ambient temperature	0 °C to +40 °C									

Wilo-Comfort control system CRn

- Automatic load-sensitive, infinitely variable speed control of glandless and glandless pumps with integrated or external frequency converter.
- For heating/air-conditioning according to the differential pressure Δp , feed/return temperature ($\pm T$) or differential temperature (ΔT) in-

cluding free adjustment of the duty point by means of the advance correction of the full-load pump output.

- Device version
 - Wall-mounted installation
 - Control-panel installation

Connection data Wilo-CRn

Electrical connection	1~230 V (shock-proof plug)/N/PE /50 Hz/60 Hz power connection of the pumps onsite
Output signals	0/2 – 10 V 0/4 – 20 mA
Permitted ambient temperature	0 °C to +40 °C

Wilo-Comfort control system CC

- Automatic, load-sensitive, infinitely variable speed control of glanded and glandless pumps with three-phase motor.
- For heating/air-conditioning according to the differential pressure Δp , feed/return temperature ($\pm T$) or differential temperature (ΔT) including free adjustment of the duty point by means of the advance

correction of the full-load pump output. For pressure boosting according to the pressure (p).

- Device version
 - Wall-mounted installation
 - Control-panel installation

Connection data Wilo-CC

Device grading: Max. nominal motor power P_2 [kW] 3~400 V/50 Hz/60 Hz	1.1	1.5	2.2	3.0	4.0	5.5	7.5	11.0	15.0	18.5	22.0	30.0	37.5	45.0	55.0
Max. permissible nominal pump current I [A]	3.0	3.7	5.2	7.0	9.0	13.0	16.0	24.0	32.0	37.5	43.1	61.0	72.4	89.6	106.0
Power factor $\cos \phi$	> 0.90														
Efficiency: - for P_{max} - within the permitted partial load range	> 0.93 > 0.85														

Switchgears and control devices

Wilo-Comfort control systems CR, CRn, CC

Technical data Wilo-CR, Wilo-CRn, Wilo-CC

Connection data Wilo-CC	
Electrical connection	3~400 V/PE Hz / 50 Hz
Output voltage [V]	3 x 130 V – 400 V
Output frequency [Hz]	(10 Hz) 12 Hz – 50 Hz / 60 Hz
Control range (% nominal motor speed)	40 % – 100 %
Permitted ambient temperature	0 °C to +40 °C

Accessories for Wilo-Comfort control systems CR, CRn and CC

Accessories		
Sensors	Differential pressure sensor, DDG (4 – 20 mA) (observe the measurement range)	Terminal diagram: base board, CC/CRn system
	Outdoor temperature sensor, KTY or PT 100	
	Temperature signal transmitter, TSG (included in the scope of delivery of the temperature board)	Terminal diagram: temperature board, KTY 10
Temperature board Automatic, infinitely variable speed control according to the feed or return temperature or according to the difference between feed and return temperatures	Temperature board, KTY 10: Heating system with large temperature spread (T_{\max} : +140 °C, $\Delta T_{\min} \geq 10$ K, ΔT_{\max} : 100 K), 2 TSG temperature transmitters included in the scope of delivery	Terminal diagram: temperature board, KTY 10
	Temperature board, PT 100: Cooling/air-conditioning systems with small temperature spread (T_{\max} : +140 °C, $\Delta T_{\min} \geq K$, ΔT_{\max} : 100 K)	Terminal diagram: temperature board, PT 100
CC temperature module, PT 100	Temperature range -200 °C to +500 °C, connection of PT 100, PT 1000 and Ni 1000 sensors	Terminal diagram: temperature module, PT 100
CR/CRn control board	Deactivation of each pump (up to 2 pumps) by repair switch onsite and remote adjustment of operating mode (mains / automatic) for each pump (up to 2 pumps) 3 control boards are required for 6 pumps	Terminal diagram: control board
CR/CRn DDC board	Load adjustment of the pump system (comparison of setpoint-actual values) via external controller, pump activation and deactivation, pump cycling, setpoint switchover, switch-over to remote speed control and acknowledgement of the collective fault signal via external potential-free contact	Terminal diagram: DDC board
CR/CRn signal board 1 – 2	Potential-free individual operation/individual fault signal for pumps 1 – 2 and frequency converter, status signals to the digital inputs DIG2 or DIG3 (e.g. low water, antifreeze), actual speed value or actual transmitter value (can be preselected)	Terminal diagram: signal board 1-2
CR/CRn signal board 3 – 6	Potential-free individual operation/individual fault signal for pumps 3 – 6	Terminal diagram: signal board 3-6

Dimensions and weights Wilo-CR system

Nominal power	Number of pumps	WM/FM				SE			
		W	H	D	Weight	W	H	Req. installation depth	Weight
P_2									
[kW]		[mm]			[kg]	[mm]			[kg]
1.1 – 4.0	1-4-fold	620	770	265	50	550	730	190	30
	5-6-fold	780	770	315	70	704	730	200	45
5.5 – 7.5	1-2-fold	600	1900	415	195	499	1696	210	95
	3-4-fold	800	1900	415	205	699	1696	210	105
	5-6-fold	1000	1900	415	215	899	1696	210	115
11.0 – 22.0	1-2-fold	800	1900	515	270	699	1696	310	140
	3-4-fold	1200	1900	515	350	1099	1696	310	160

¹⁾ Control system consists of 2 switch rails.

Technical data Wilo-CR, Wilo-CRn, Wilo-CC

Dimensions and weights Wilo-CR system									
11.0 – 15.0	5-6-fold	1200	1900	515	365	1099	1696	310	175
22	5-6-fold ¹⁾	1200	1900	515	–	1099	1696	310	–
		600	1900	515	520	499	1696	310	230
30	1-2-fold	1200	1900	515	390	1099	1696	310	200
	3/4-fold ¹⁾	1200	1900	515	–	1099	1696	310	–
		600	1900	515	560	499	1696	310	270
	5-6-fold ¹⁾	1200	1900	515	–	1099	1696	310	–
		1200	1900	515	640	1099	1696	310	320
Section dimension CR controller and operating unit	–	–	–	–	–	186	138	82	–

¹⁾ Control system consists of 2 switch rails.

Dimensions and weights Wilo-CRn system					
Temperature sensors	Number of pumps [pcs.]	WM		SE	
		Dimensions (W x H x D)		Dimensions (W x H x D)	
		[mm]	[kg]	[mm]	[kg]
PT 100	1 – 2	400 x 400 x 200		360 x 380 x 120	
PT 100	3 – 4	400 x 400 x 200		360 x 380 x 120	
KTY	1 – 2	400 x 400 x 200		360 x 380 x 120	
KTY	3 – 4	400 x 400 x 200		360 x 380 x 120	

Dimensions and weights Wilo-CC system			
Nominal power P ₂ [kW]	Number of pumps [pcs.]	Dimensions (W x H x D) [mm]	Weight [kg]
0.75 – 4.0	1-4	600 x 760 x 250	50
	5-6	760 x 760 x 250	70
5.5 – 7.5	1-2	600 x 1900 x 500	175
	3-4	800 x 1900 x 500	205
	5-6	1000 x 1900 x 400	230
11.0 – 15.0	1-2	800 x 1900 x 500	220
	3-4	1000 x 1900 x 400	270
11.0	5-6	1000 x 1900 x 400	300
15.0	5-6	1200 x 1900 x 500	360
18.5 – 22.0	1-2	800 x 1900 x 500	250
	3-4	1000 x 1900 x 400	320
	5-6	1800 x 1900 x 500	500
30	1-2	800 x 1900 x 500	270
	3-4	1200 x 1900 x 500	380
	5-6	2000 x 1900 x 500	580

Switchgears and control devices

Wilo-Comfort control systems CR, CRn, CC

Terminal diagrams Wilo-CR, Wilo-CRn, Wilo-CC

Terminal diagram, CR system base board

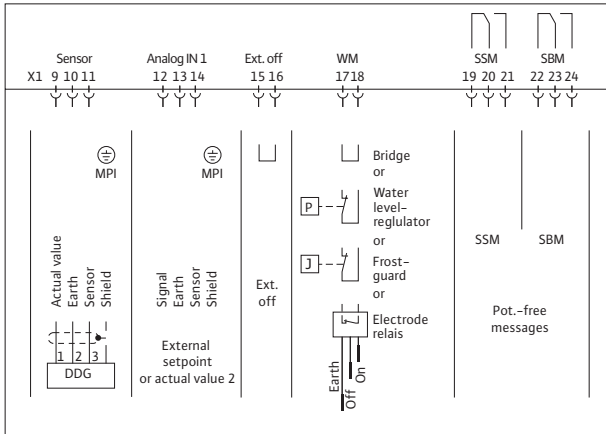

Terminal diagram drives CR system ($P_2 \leq 4 \text{ kW}$)

Terminal diagram drives CR system ($P_2 \geq 5.5 \text{ kW}$)

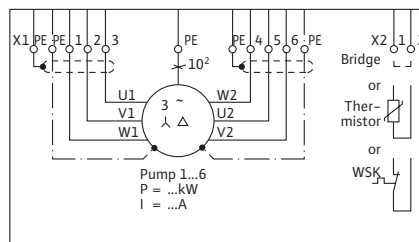
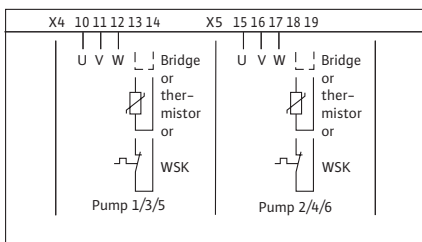

Terminal diagram base board CRn system (for pump drives 1~230 V)

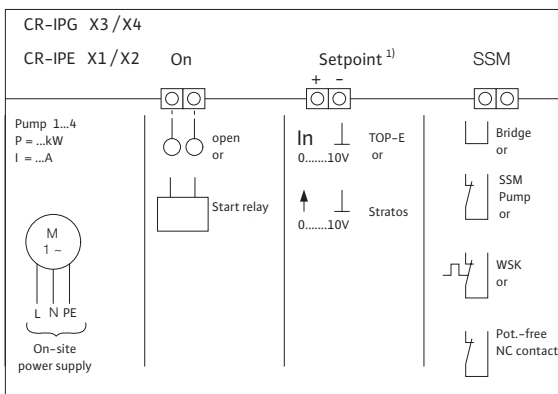

¹⁾ Required for Stratos IF-Modul with 0...10 V input (IF-Modul Stratos SBM, Stratos Ext. Min, Stratos Ext. Aus)

Terminal diagrams Wilo-CR, Wilo-CRn, Wilo-CC

Terminal diagram expansion board CRn system (for pump drives 3~400 V)

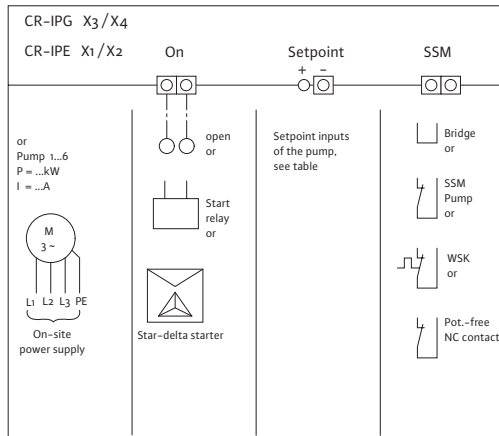

Terminal diagram CC-HVAC, direct starting, with frequency converter

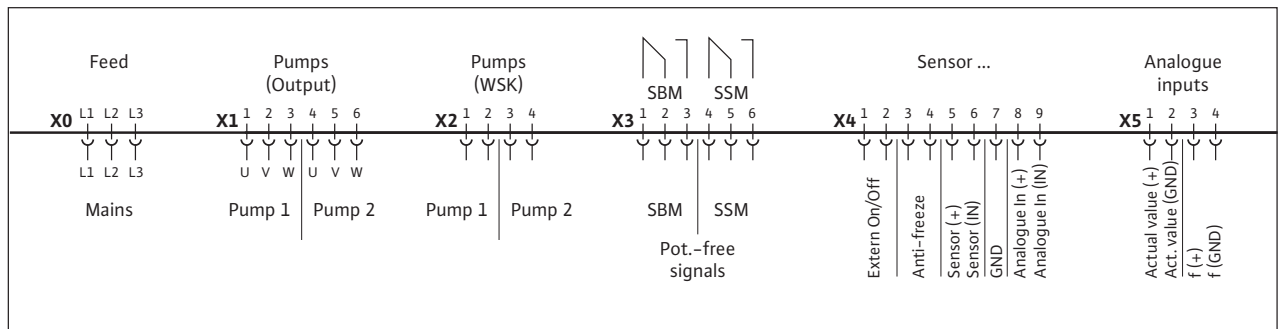

Terminal diagram CC-HVAC, Y-Δ-starting, with frequency converter

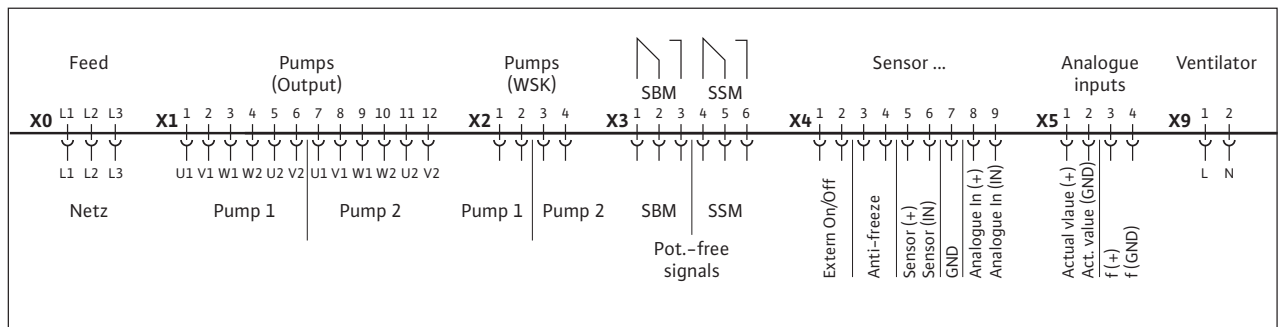

Switchgears and control devices

Wilo-Comfort control systems CR, CRn, CC

Terminal diagrams Wilo-CR, Wilo-CRn, Wilo-CC

Wilo-CRn system, assignment of the setpoint outputs: 1. at the CRn control device / 2. at the pump to be controlled

Pump type		Analogue control signal	1. Setpoint outputs, CRn:	
			+	-
			2. Setpoint inputs, pump:	
IL-E...BF R1	(from year of construction 08/2002 to 02/2003)	0 - 10 V	2	4 GND
IL-E...BF R1	(from year of construction 08/2002 to 02/2003)	0 - 20 mA	2	4 GND
IL-E...BF R1	(from year of construction 03/2003)	0 - 10 V	2	7 GND
IL-E...BF R1	(from year of construction 03/2003)	0 - 20 mA	2	7 GND
IL-E... R1	(from year of construction 01/2003)	0 - 10 V	1 (0 - 10 V)	2 (GND)
IL-E... R1	(from year of construction 01/2003)	0 - 20 mA	4 - 20 mA	2 (GND)
IP-E	-	0 - 10 V	1	2
IP-E	-	4 - 20 mA	1	2

Signal transmitters and accessories

Wilо DDG signal transmitter

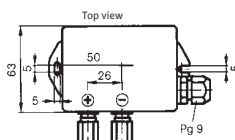
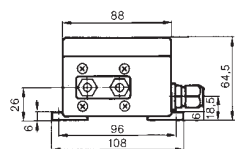

DDG 10 to 100 (DDG 2 without illustration)

(Dimensions in mm), fastening elements onsite

Signal transmitter for wall-mounted installation for infinitely variable speed control according to the differential pressure.

With built-in pressure-surge throttles, 2 DIN 3862, \varnothing 6 mm cutting-ring unions, 5 m connection cable to the switchgear¹⁾ (3 x 0.75 mm²), 2 angle cutting-ring unions R $\frac{1}{8}$ x \varnothing 6 mm.

1) Longer distances to be extended by customer

up to 25 m: x 0.75 mm², shielded, up to 250 m: 3 x 1.5 mm², shielded

Maximum operating voltage: 15 – 30 VDC

Current output: 4 – 20 mA

Maximum load resistance: 500 Ω

Pressure measurement ranges:^{2) 3)}

DDG 2: 0 to 0.2 bar*

DDG 10: 0 to 1.0 bar

DDG 20: 0 to 2.0 bar

DDG 40: 0 to 4.0 bar

DDG 60: 0 to 6.0 bar

DDG 100: 0 to 10.0 bar*

2) Other pressure measurement ranges on request

3) Selection of pressure measurement range according to the pump duty point

Power consumption: 1.5 W

Protection class: IP 54

Maximum pressure rating: 25 bar

Fluid temperature: 0 °C to +70 °C

Ambient temp.: 0 °C to +40 °C

DDG transducer

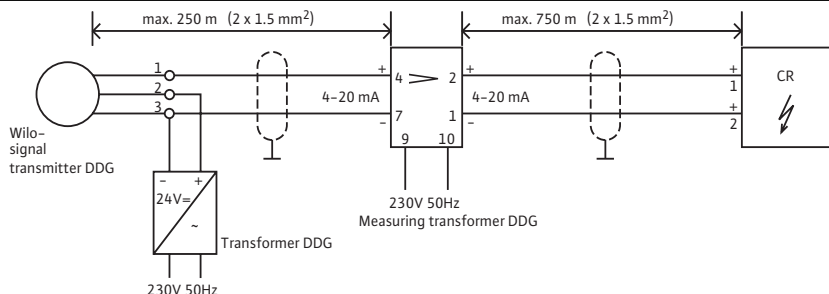
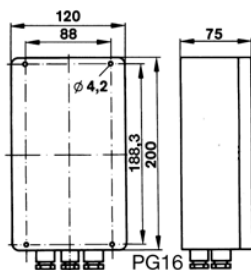

Transducer for wall-mounted installation for amplifying signals from the Wilo DDG signal transmitter for cable lengths in excess of 250 m.

Delivery incl. DDG power supply unit.

Maximum power consumption: 5 VA

Protection class: IP 54

Ambient temperature: 0 °C to + 40 °C

Signal cable

Operating voltage: 230 V/50 Hz

Current input/output: 0 – 20 mA

Max. back-up fuse: 10 A

Maximum input resistance: 50 Ω

Maximum load resistance: \leq 600 Ω

Input: 2 x 1.5 mm², 250 m max. length, shielded
Output: 2 x 1.5 mm², 750 m maximum length, shielded

Switchgears and control devices

Switchgears

Signal transmitters and accessories

DDG power supply unit

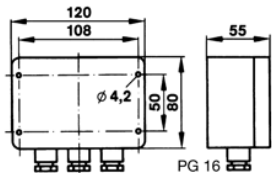

Fastening elements onsite

Power supply unit for wall-mounted installation for power supply of the DDG signal transmitter.

Protection class: IP 54
Ambient temperature: 0 °C to +40 °C

Operating voltage: 230 V/50 Hz
Output voltage: 24 V DC
Output current: 0 – 20 mA

Outdoor temperature sensor KTY/PT 100

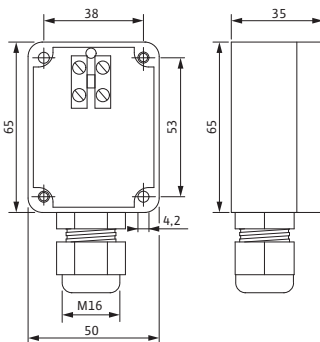

Signal transmitter for wall-mounted installation for outdoor temperature measurement.

> Technical data

Protection class: IP 65
Temperature range: –25 °C to +80 °C

Required: Connection line (provided by the customer)
up to 25 m: 3 x 0.75 mm², shielded
up to 100 m: 3 x 1.50 mm², shielded
up to 250 m: 3 x 2.50 mm², shielded

KTY 10 temperature board

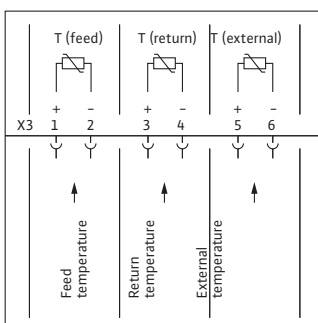

Terminal diagram, KTY 10 temperature board

Additional board for upgrading Wilo-CR/CRn system switchgear series for use of the control modes

- Differential temperature control (ΔT)
- Feed/return temperature control ($\pm T$)
- Differential pressure – temperature–superimposed ($\Delta p-T$)

3 analogue inputs for TSG temperature sensors:

- Feed temperature (+T)
- Return temperature (–T)
- Temperature setpoint (T)

Fixation material, CAN bus cable and 2 TSG temperature signal transmitters are included in the scope of delivery.

> Technical data

Measurement range: $\pm T$: – 20 ... +150 °C
 ΔT : ≥ 10 K
Resolution: 10 bits
Accuracy: 0.2% of upper limit + transmitter tolerance
Ambient temperature: 0 °C to +40 °C
Dimensions: 100 mm x 120 mm
Weight: approx. 0.5 kg

Signal transmitters and accessories

TSG signal transmitter

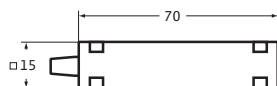

Signal transmitter for pipe attachment for temperature measurement included in the scope of delivery of the KTY 10 temperature board. With 2 spring fasteners for attachment to pipes up to DN 100, 1 tube of thermal conducting glue, 5 m connecting cable for switchgear¹⁾ (2 x 0.75 mm², shielded)

KTY 10 PTC thermistor

- at +25 °C: 2 kΩ
- at +90 °C: 3.09 kΩ
- Max. current: 2 mA

¹⁾ Longer distances to be extended by customer

- up to 25 m: 3 x 0.75 mm², shielded,
- up to 100 m: 3 x 1.50 mm², shielded,
- up to 250 m: 3 x 2.50 mm², shielded

Protection class: IP 43
Temperature range: 0 °C to +150 °C

Temperature board PT 100

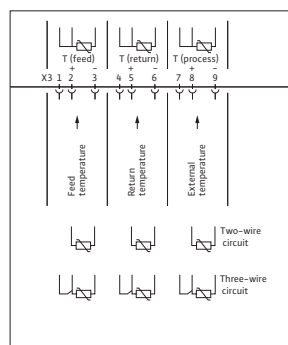

Terminal diagram, PT 100 temperature board

Additional board for upgrading switchgears of the Wilo-CR/CRn system series for use of the control modes

- Differential temperature control (ΔT)
- Feed/return temperature control ($\pm T$)
- Differential pressure – temperature-superimposed ($\Delta p-T$)

3 analogue inputs for PT 100 temperature sensors in 2-/3- and 4-conductor technology to be provided by the customer:

- Feed temperature (+T)
- Return temperature (-T)
- Temperature setpoint (T)

Fixation material and CAN bus cable are included in the scope of delivery.

> Technical data

Measurement range: $\pm T$: - 20 ... +150 °C
 ΔT : ≥ 5 K
Accuracy: ± 2 K (in relation to standard values in accordance with DIN IEC 751) + transmitter tolerance
Ambient temperature: 0 °C to +40 °C
Dimensions: 100 mm x 120 mm
Weight: approx. 0.5 kg

DDC board

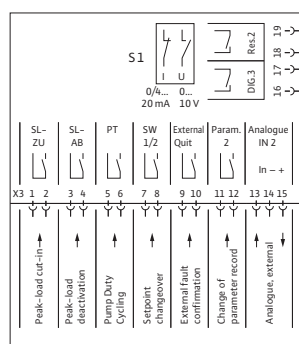

Terminal diagram, DDC board

Additional board for upgrading switchgears of the Wilo-CR/CRn system series for remote control by external monitoring units (e.g. BA or DDC substation).

1 analogue input for external correcting variable (speed adjustment for DDC operation)
8 digital inputs for connection of an external potential-free button for

- Peak-load cut-in
- Peak-load deactivation
- Pump cycling
- Setpoint changeover
- Acknowledgement of the collective fault signal
- Parameter record switching
- Control input, 0/2 - 10 V or 0/4 - 20 mA
- Signal input DIG 3

Fixation material and CAN bus cable are in-

Analogue input: Correcting variable: 0 - 10 V, 0/4 - 20 mA (= min. - max. speed)
Input resistance: 10kΩ or 50 Ω
Resolution: 10 bits
Accuracy: 0.2% of upper limit + transmitter tolerance
Digital inputs:
Input level: 24 VDC / 1 mA
Dielectric strength: 250 VAC
Maximum cable length: 100 m
Terminal cross-sections: 1.5 mm²
Ambient temp.: 0 °C to +40 °C
Dimensions: 100 mm x 120 mm
Weight: approx. 0.5 kg

Switchgears and control devices

Switchgears

Signal transmitters and accessories

Control board

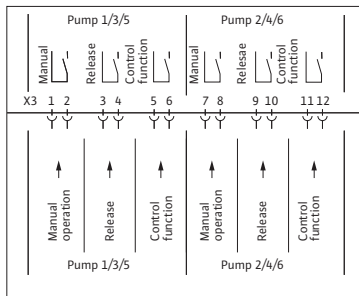

Terminal diagram, control board

Additional board for upgrading switchgears of the Wilo-CR/CRn system series for Manual – 0 – Automatic operating mode selection for a maximum of 2 pumps (e.g.: 5-pump system requires 3 control boards). Switchover for each pump via potential-free control switches provided by the customer.

Manual – 0 – Automatic switchover via potential-free two-way NO contacts provided by the customer with "Off" middle position for each pump.
Operating mode:

- Manual: Pump in mains operation
- 0: Pump Off
- Automatic: Pump enabled for control mode

Connection for repair switches provided by the customer with auxiliary contact:

- closed: Pump enabled
- open: Pump disabled

Fixation material and CAN bus cable are included in the scope of delivery.

Selector switch:	P1/P2, P3/P4, P5/P6
Control inputs:	2 x repair switches (On/Off for each pump) 2 x control switches (Manual – 0 – Automatic for each pump)
Input level:	24 VDC / 1 mA
Dielectric strength:	250 VAC
Maximum cable length:	100 m
Terminal cross-sections:	1.5 mm ²
Ambient temp.:	0 °C to +40 °C
Dimensions:	100 mm x 120 mm
Weight:	approx. 0.5 kg

Signal board 1 – 2

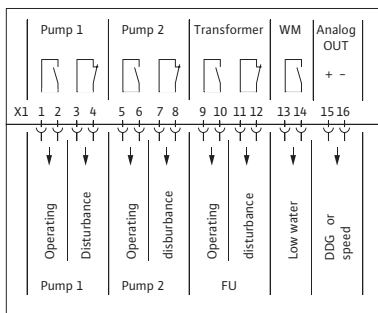

Terminal diagram, signal board 1 – 2

Additional board for upgrading switchgears of the Wilo-CR/CRn system series for individual run and single fault signals for single and double pump systems.

- Potential-free signalling contacts for operation (NO contact) and fault (NC contact) of: pump 1, pump 2, frequency converter
- Signals for the digital inputs DIG2 or DIG3, e.g. frost (heating) or low water (pressure boosting)
- Analogue output for actual speed value or actual value transmitter (can be preselected)

Fixation material and CAN bus cable are included in the scope of delivery.

Analogue output:	Actual value
Measurement range:	0 – 10 V, 0/4 – 20 mA (speed or transmitter)
Input resistance:	10 kΩ or 50 Ω
Resolution:	10 bits
Accuracy:	0.2% of upper limit + transmitter tolerance
Signalling contacts	
Rating:	max. 250 VAC/2 A min. 12 VDC/10 mA
Maximum cable length:	100 m
Terminal cross-sections:	1.5 mm ²
Ambient temp.:	0 °C to +40 °C
Dimensions:	120 mm x 120 mm
Weight:	approx. 0.5 kg

Signal transmitters and accessories

Signal board 3 – 6

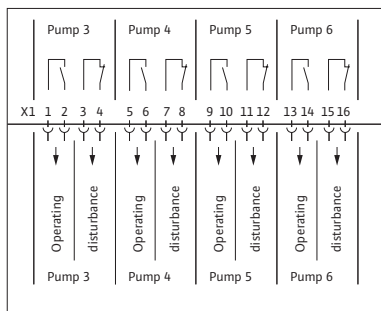

Terminal diagram, signal board 3 – 6

Additional board for upgrading switchgears of the Wilo-CR/CRn series for individual run/single fault signals for three-pump to six-pump systems (signal board 1 – 2 also required).

- Potential-free signalling contacts for operation (NO contact) and fault (NC contact) of: pump 3, pump 4, pump 5, pump 6
Fixation material and CAN bus cable are included in the scope of delivery.

Signalling contacts

Rating:	max. 250 VAC/2 A min. 12 VDC/10 mA
Terminal cross-sections:	1.5 mm ²
Ambient temp.:	0 °C to +40 °C
Dimensions:	120 mm x 120 mm
Weight:	approx. 0.5 kg

Wilo Catalogue Edition 2009

Heating, air-conditioning, cooling

Circulation pumps

Glandless pumps and accessories, package heat exchanger assembly

Catalogue A1



Heating, air-conditioning, cooling

Glanded pumps

Pumps with in-line design and accessories

Catalogue A2



Heating, air-conditioning, cooling, water supply

Monobloc and norm pumps, axial split case pumps

Pumps and accessories

Catalogue A3



Water supply

Domestic water supply, rainwater utilisation

Pumps, systems and accessories

Catalogue B1



Water supply

Borehole pumps, 3" to 24"

Pumps and systems for building services, domestic, municipal and industrial water supply



Catalogue B2



Water supply

High-pressure multistage centrifugal pumps

Pumps and accessories

Catalogue B3



Water supply

Pressure boosting systems

Single-pump and multi-pump systems in dry well installations

Catalogue B4



Water supply

Sprinkler pumps with VdS approval

Borehole pumps and accessories



Catalogue B5



Drainage and sewage

Drainage pumps

Submersible pumps, self-priming pumps and accessories



Catalogue C1



Drainage and sewage

Sewage pumps, DN 32 to DN 600

Submersible pumps and accessories for building services, municipal and industrial applications



Catalogue C2



Drainage and sewage

Wastewater and sewage lifting units, pumps stations

Pump systems and accessories

Catalogue C3



Drainage and sewage

Submersible mixers

Mixers, re-circulation pumps, jet cleaners, grit collector pumps and accessories for municipal application in water treatment systems



Catalogue C4





Pumpen Intelligenz.

WILO SE
Nortkirchenstraße 100
44263 Dortmund
Germany
T +49 231 4102-0
F +49 231 4102-7363
wilo@wilo.com
www.wilo.com

Wilo – International (Subsidiaries)

Argentina
WILO SALMSON
Argentina S.A.
C1295ABI Ciudad
Autónoma de Buenos Aires
T+ 54 11 4361 5929
info@salmson.com.ar

Austria
WILO Pumpen
Österreich GmbH
1230 Wien
T +43 507 507-0
office@wilo.at

Azerbaijan
WILO Caspian LLC
1065 Baku
T +994 12 5962372
info@wilo.az

Belarus
WILO Bel OOO
220035 Minsk
T +375 17 2503393
wilobel@wilo.by

Belgium
WILO SA/NV
1083 Ganshoren
T +32 2 4823333
info@wilo.be

Bulgaria
WILO Bulgaria Ltd.
1125 Sofia
T +359 2 9701970
info@wilo.bg

Canada
WILO Canada Inc.
Calgary, Alberta T2A 5L4
T +1 403 2769456
bill.lowe@wilo-na.com

China
WILO China Ltd.
101300 Beijing
T +86 10 80493900
wiloobj@wilo.com.cn

Croatia
WILO Hrvatska d.o.o.
10090 Zagreb
T +38 51 3430914
wilo-hrvatska@wilo.hr

Czech Republic
WILO Praha s.r.o.
25101 Cestlice
T +420 234 098711
info@wilo.cz

Denmark
WILO Danmark A/S
2690 Karlslunde
T +45 70 253312
wilo@wilo.dk

Estonia
WILO Eesti OÜ
12618 Tallinn
T +372 6509780
info@wilo.ee

Finland
WILO Finland OY
02330 Espoo
T +358 207401540
wilo@wilo.fi

France
WILO S.A.S.
78390 Bois d'Arcy
T +33 1 30050930
info@wilo.fr

Great Britain
WILO (U.K.) Ltd.
DE14 2WJ Burton-
Upon-Trent
T +44 1283 523000
sales@wilo.co.uk

Greece
WILO Hellas AG
14569 Anixi (Attika)
T +302 10 6248300
wilo.info@wilo.gr

Hungary
WILO Magyarország Kft
2045 Törökbálint
(Budapest)
T +36 23 889500
wilo@wilo.hu

Ireland
WILO Engineering Ltd.
Limerick
T +353 61 227566
sales@wilo.ie

Italy
WILO Italia s.r.l.
20068 Peschiera
Borromeo (Milano)
T +39 25538351
wilo.italia@wilo.it

Kazakhstan
WILO Central Asia
050002 Almaty
T +7 727 2785961
in.pak@wilo.kz

Korea
WILO Pumps Ltd.
621-807 Gimhae
Gyeongnam
T +82 55 3405800
wilo@wilo.co.kr

Latvia
WILO Baltic SIA
1019 Riga
T +371 67 145229
mail@wilo.lv

Lebanon
WILO SALMSON
Lebanon
12022030 El Metn
T +961 4 722280
wsl@cyberia.net.lb

Lithuania
WILO Lietuva UAB
03202 Vilnius
T +370 5 2136495
mail@wilo.lt

The Netherlands
WILO Nederland b.v.
1551 NA Westzaan
T +31 88 9456 000
info@wilo.nl

Norway
WILO Norge AS
0975 Oslo
T +47 22 804570
wilo@wilo.no

Poland
WILO Polska Sp. z o.o.
05-090 Raszyn
T +48 22 7026161
wilo@wilo.pl

Portugal
Bombas Wilo-Salmson
Portugal Lda.
4050-040 Porto
T +351 22 2080350
bombas@wilo.pt

Romania
WILO Romania s.r.l.
077040 Com. Chiajna
Jud. Ilfov
T +40 21 3170164
wilo@wilo.ro

Russia
WILO Rus ooo
123592 Moscow
T +7 495 7810690
wilo@orc.ru

Saudi Arabia
WILO ME – Riyadh
Riyadh 11465
T +966 1 4624430
wshoula@watanaiand.com

Serbia and Montenegro
WILO Beograd d.o.o.
11000 Beograd
T +381 11 2851278
office@wilo.co.yu

Slovakia
WILO Slovakia s.r.o.
82008 Bratislava 28
T +421 2 45520122
wilo@wilo.sk

Slovenia
WILO Adriatic d.o.o.
1000 Ljubljana
T +386 1 5838130
wilo.adriatic@wilo.si

South Africa
Salmson South Africa
1610 Edenvale
T +27 11 6082780
errol.cornelius@
salmson.co.za

Spain
WILO Ibérica S.A.
28806 Alcalá de Henares
(Madrid)
T +34 91 8797100
wilo.iberica@wilo.es

Sweden
WILO Sverige AB
35246 Växjö
T +46 470 727600
wilo@wilo.se

Switzerland
EMB Pumpen AG
4310 Rheinfelden
T +41 61 83680-20
info@emb-pumpen.ch

Taiwan
WILO-EMU Taiwan Co. Ltd.
110 Taipei
T +886 227 391655
nelson.wu@
wiloemutaiwan.com.tw

Turkey
WILO Pompa Sistemleri
San. ve Tic. A.Ş.
34530 Istanbul
T +90 216 6610211
wilo@wilo.com.tr

Ukraine
WILO Ukraina t.o.w.
01033 Kiev
T +38 044 2011870
wilo@wilo.ua

Vietnam
Pompes Salmson Vietnam
Ho Chi Minh-Ville Vietnam
T +84 8 8109975
nkm@salmson.com.vn

United Arab Emirates
WILO ME – Dubai
Dubai
T +971 4 3453633
info@wilo.com.sa

USA
WILO-EMU USA LLC
Thomasville,
Georgia 31792
T +1 229 5840097
info@wilo-emu.com

USA
WILO USA LLC
Melrose Park, Illinois 60160
T +1 708 3389456
mike.easterley@
wilo-na.com

Wilo – International (Representation offices)

Algeria
Bad Ezzouar, Dar El Beida
T +213 21 247979
chabane.hamdad@salmson.fr

Armenia
375001 Yerevan
T +374 10 544336
info@wilo.am

Bosnia and Herzegovina
71000 Sarajevo
T +387 33 714510
zeljko.cvjetkovic@wilo.ba

Georgia
0179 Tbilisi
T +995 32 306375
info@wilo.ge

Macedonia
1000 Skopje
T +389 2 3122058
valerij.vojneski@wilo.com.mk

Mexico
07300 Mexico
T +52 55 55863209
roberto.valenzuela@wilo.com.mx

Moldova
2012 Chisinau
T +373 2 223501
sergiu.zagorean@wilo.md

Rep. Mongolia
Ulaanbaatar
T +976 11 314843
wilo@magicnet.mn

Tajikistan
734025 Dushanbe
T +992 37 2232908
farhod.rahimov@wilo.tj

Turkmenistan
744000 Ashgabad
T +993 12 345838
wilo@wilo-tm.info

Uzbekistan
100015 Tashkent
T +998 71 1206774
info@wilo.uz

March 2009